

**CARE FOR
YOUR CYCLE**

RALEIGH

**OWNERS
HANDBOOK**

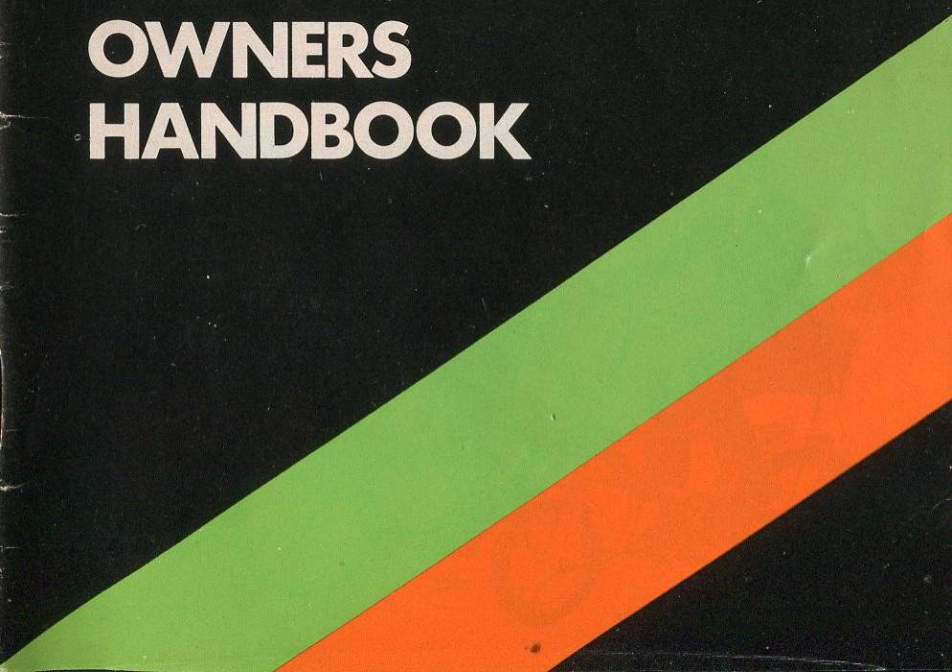

contents

	Page		Page
Bearing Adjustment	14	Identification Form	39
Bottom Bracket	12	Lubrication	6
Brake Levers	19	Lighting Equipment	37
Cable Brakes	18	Pedals	11
Cleaning and Storing	5	Riding Position	7
Chain	13	Roller Lever Brakes	16, 17
Deraillleur Gears	24, 29	Saddle Adjustment	9, 10
Dynohub bearing adjustment	36	Steering Head	12
Folding Models	39	Sportshift Gear Cable	33
Good Cycling	3, 4	Sturmey-Archer Hubs	30, 34, 35
Handlebar Adjustment	8, 9	Trigger Control	31
Holdalls & Carriers	38	Twist Grip Control	32
Hub Brakes	20	Tyres	21, 22, 23
Hub Bearings	14	Wheels	15



good cycling

To become a good cyclist and to enjoy cycling it is important that you keep your Raleigh bicycle in good condition at all times. In the pages that follow we tell you, with the help of drawings, how to maintain and adjust your bicycle to keep it ready for the road at all times.

BEFORE RIDING ALWAYS

CHECK

- 1) Your brakes are properly adjusted and function correctly.

CHECK

- 2) Your lights are functioning correctly.

CHECK

- 3) Your tyres are not worn and are correctly inflated to the pressure shown on the tyre wall.

CHECK

- 4) Your gears are properly adjusted and function correctly.

CHECK

- 5) All nuts and bolts are tight.

WHEN RIDING ALWAYS

- a) Hold the handlebar, and keep your feet on the pedals.
- b) Obey all traffic regulations.
- c) Do not ride more than two abreast. Ride in single file on busy or narrow roads. Do not weave in and out of traffic.
- d) Give clear hand signals to warn other road users of your intentions.
- e) Give way to pedestrians.
- f) Do not carry anything which may effect your balance.
- g) Do not carry a passenger unless the cycle has been built or altered to carry one.
- h) Do not hold on to another vehicle or another cyclist.
- i) Do not ride too close behind another vehicle.
- j) If there is a cycle path beside the road – ride on it.

In the UK, cyclists are advised to obtain the latest edition of 'THE HIGHWAY CODE' – which can be obtained from Post Offices and most good book shops. Also ask at your school or nearest police station for information about the National Cycling Proficiency Scheme – which can be invaluable in learning all about "Good Cycling".

Looking after your cycle

Your bicycle will last much longer, run better and continue to look as good as new if it is cleaned and lubricated regularly.

Cleaning

Clean the enamel and the chrome parts of your bicycle with warm soapy water, rinse with clean water and finish with a dry duster. Use only a good quality wax polish. Occasionally remove the chain from the cycle and clean thoroughly with paraffin (kerosene) making sure all grit is removed. Dry with a clean cloth and soak in a saucer of oil for about an hour before draining and refitting to the bicycle.

Storing

Before storing your bicycle for any length of time, say through the winter, smear all the chromium parts with a light grease. However, before using your cycle again be sure to clean ALL the oil or grease from the brake tracks on the rims. Never store a cycle standing on its tyres, either hang it up or store upside down.

lubrication

REGULAR LUBRICATION IS IMPORTANT

Lubricate the parts shown when new and every two weeks when in use. **Do not allow surplus oil to run down spokes and ruin tyres.**

Important

Keep oil and grease away from brake tracks on wheel rims — also from brake blocks.

If the cycle has been idle for some time, lubricate before using. **DO NOT OVER-OIL.** If a gearcase is fitted remove gearcase end and lubricate the chain while revolving the cranks.

On some models the Bottom Bracket, Pedals and Hubs do not have a lubricator provided in which case these bearings have been grease packed before leaving the factory, giving lubrication over a long period without attention.

When not in regular use cycle should be hung up to protect tyres. Metal parts should be lightly smeared with grease if storage is for an extended period.

TAKE CARE to remove grease or oil from brake tracks on wheel rims before using cycle again.

Use only R.I. 'ALL-PURPOSE' Oil or STURMEY ARCHER Oil — specially blended high grade lubricants.

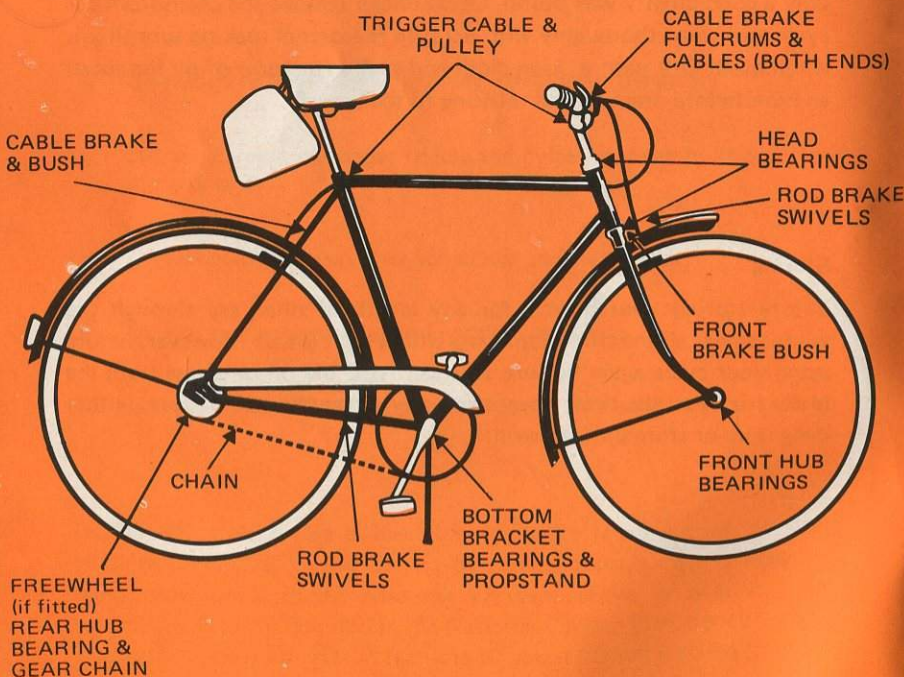

riding position

The best riding position is the one which gives **YOU**, the rider, the greatest comfort consistent with good balance. No two people ride alike but the following hints should help you to find your most comfortable, efficient position. Correct saddle height is most important. This can usually be determined by fully extending the leg (when seated on the saddle) and placing the heel on the pedal with the pedal at its lowest point. This allows for a slight bend at the knee when the ball of the foot is on the pedal. Tilt the nose of the saddle slightly upwards. Your saddle is usually at its most comfortable angle when its nose is about two inches behind a vertical line rising from the centre of the bottom bracket to which the chainwheel and pedal cranks are fixed.

Your weight should be so balanced that your hands rest lightly on the handlebars. This prevents strain on wrists and forearms when pedalling. If the angle of the hand grips is adjusted remember to tighten the handlebar stem nut.

handlebar SPORTS AND RACING TYPE

Alternative Riding Positions

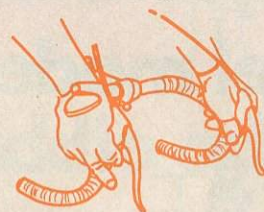

Normal riding position. Hands are over brake lever hoods, fingers are on brake levers.

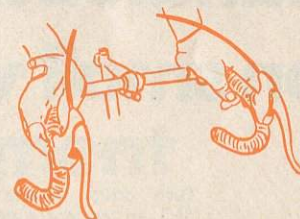

Hands on bend. This position is used to relieve muscle tension.



Hands on top. Used to obtain greater power from back muscles — for hill climbing.



Hands on bottom. This streamlined body position reduces wind resistance.

handlebar adjustment

To raise or lower your handlebars loosen expander bolt "X" two turns and give it a firm but gentle tap. This releases the expander cone and allows the stem to move. (If the head of the expander bolt is recessed in the stem — the correct size of Allen key should be used to loosen the bolt). When you have set the handlebars at the new height re-tighten bolt "X" but, before you do this, make sure that at least 2½ inches of handlebar stem remains in the fork steering tube.

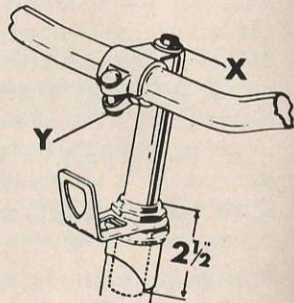

With rod brakes loosen brake tube nuts to allow the brake rods to take up the new position, then re-adjust as shown on pages 14 and 15.

If the angle of handlebars requires adjustment, loosen nut "Y" and rotate bars to the desired angle. Tighten nut "Y".

handlebar adjustment on small wheel models

Turn quick release lever "A" in an anti-clockwise direction to loosen the handlebars — raise or lower to the required height and tighten firmly by turning lever "A" in a clockwise direction.

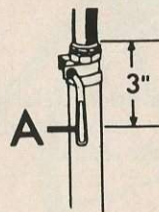

NOTE

The handlebars cannot be separated from the frame as they are fitted with a restrictor, the purpose of which is to ensure that at least 3" of the handlebar stem remains within the fork column with handlebars fully raised. If it becomes necessary to remove the handlebars, consult your cycle dealer who is specially equipped to do this job.

handlebar adjustment on Chopper models

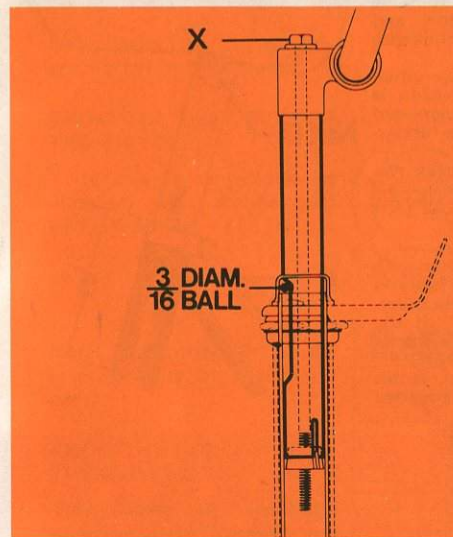

NOTE:—

The "Chopper" handlebars are fitted with a restrictor device (Patent applied for). The restrictor allows height of handlebars to be adjusted within the recommended safety limit.

saddle adjustment

HOW TO ADJUST YOUR SADDLE HEIGHT. Raise or lower by loosening nut "A". Be sure that at least 2½ in. of the saddle pillar remains in the frame.

FORWARD or BACKWARD. By loosening nuts "B" on either side of the saddle its chassis can be moved forward or backwards.

By reversing the clip (as shown on dotted line "C") the saddle can be set further back.

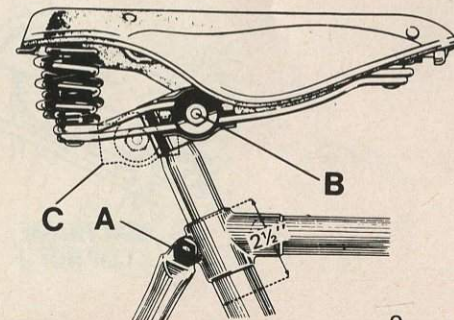

saddle adjustment small wheel models

Turn the quick release lever "A" in an anti-clockwise direction to allow the saddle to move up or down to the required position, and finally tighten lever "A" firmly in a clockwise direction to lock.

In order to facilitate maximum leverage when locking the saddle into position, provision is made for positioning lever "A" in a downward direction, by adjustment of the square 'under-head' of the bolt in the seat lug.

To adjust the saddle angle, simply loosen nut "B" on either side of the saddle frame. **BE SURE TO TIGHTEN THESE NUTS AFTER ADJUSTMENT.**

IMPORTANT WARNINGS:

1. Your machine must never be ridden with the saddle raised out of the frame beyond the 'limit' mark visible on the saddle pillar. This is to ensure that at least 3" of the saddle pillar remains inserted in the frame. **DO NOT ADJUST BEYOND THIS HEIGHT.**
2. Do not apply pressure with any tool, as this may result in damage to the finely threaded locking system.

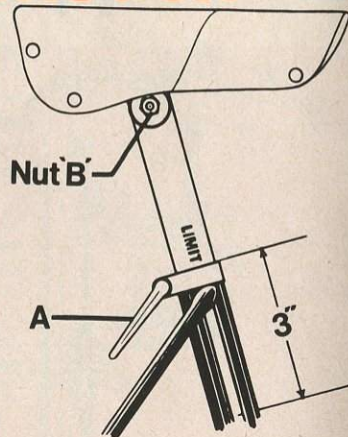

Chopper models

RAISE OR LOWER BY LOOSENING SEAT FRAME NUT "J" AND SEAT BRACE CLIP NUTS "F". BE SURE THAT AT LEAST 2" OF SEAT PILLAR AND SEAT BRACE REMAIN IN FRAME TUBES.

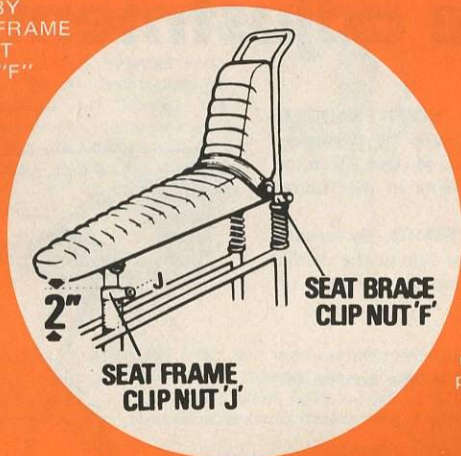

The "Chopper" bicycle is not designed to carry a passenger.

NOTE:
Under Section 13 of the U.K. Road Traffic Act of 1960, it is an offence for two people to ride a bicycle unless this is specially adapted.

pedals

WARNING — ALWAYS — KEEP PEDAL AXLES TIGHT

Note: Pedal with "L" on axle end fits in left hand crank.

FROM THE LEFT SIDE OF THE BICYCLE:—

Turn axle in anti-clockwise direction with spanner and FULLY tighten.

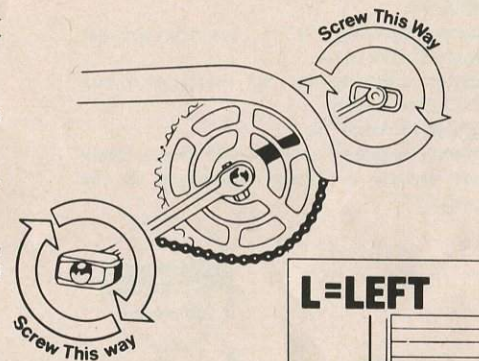

Note: Pedal with "R" on the axle end fits in chainwheel crank.

FROM THE RIGHT SIDE OF THE BICYCLE:—

Turn axle in clockwise direction with spanner and FULLY tighten.

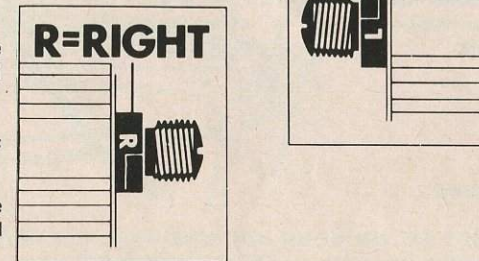

toe clips and straps

If toe clips and straps are not originally supplied on your cycle, they can be added easily. Simply bolt the clip to the front plate of the pedal as illustrated.

The toe strap is fitted through the pedal from the outside edge, twisted in between pedal edges to avoid slipping and laced through the toe clip eye. The buckle should rest on the top of foot, otherwise it will press on outside edge and may cause discomfort.

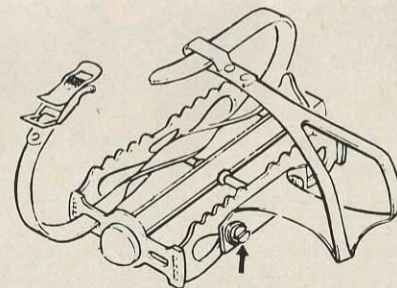

bottom bracket bearings

TO ADJUST

1. Loosen locking "A" — use the spanner supplied with cycle.
2. Tighten adjusting cup "B" then slacken cup "B" 1/8 of a turn.
3. Tighten locking "A".

A correctly adjusted axle should rotate freely without vertical or lateral movement at the axle ends.

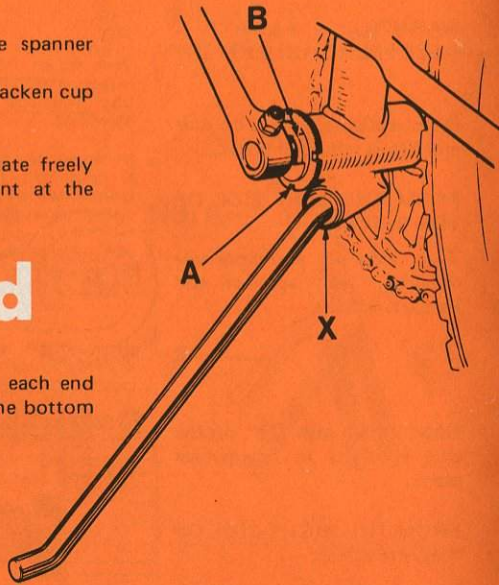

prop stand

Occasional lubrication is required at each end of the tubular housing, "X" under the bottom bracket.

WARNING

DO NOT SIT ON YOUR MACHINE WITH THE PROP STAND DOWN — it is designed to support the machine — not the rider.

steering head

IMPORTANT

Steering should be smooth and easy. There should be no front wheel judder when the front brake is applied.

TO ADJUST, loosen locknut (A) then tighten head nut (B) gently. Tighten locknut (A).



chain

A correctly adjusted chain should have about 1/2" free movement at centre between chainwheel and sprocket.

To adjust chain tension — loosen rear wheel axle nuts — push wheel backwards ensuring that wheel remains central between rear forks — tighten axle nuts.

To tension the chain on machines fitted with chain adjuster, loosen nuts "A" and tighten chain adjuster nuts "B" evenly, ensuring that wheel remains central between rear forks. Tighten axle nuts. If chain is removed, see that connecting link is closed and facing direction of movement; see "C".

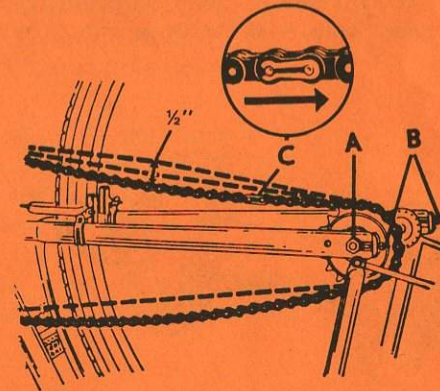

To adjust chain on gearcase models, first remove gearcase end. This is done by removing the end cap screw.

NOTE: This illustration shows cycle in the upside-down position.

Occasionally remove chain from cycle and clean thoroughly (see page 4).

derailleur gear chain

A derailleur gear chain must be rivetted together (do not use a connecting spring link). Stiff chain links will cause the chain to fall off the chainwheel during gear changes. Ask your dealer to free any stiff links.

A chain of correct length must be used.

A short chain will cause stiff gear change — chain should be in contact with upper chain roller and long enough to allow free movement onto largest chainwheel and sprocket.

hub bearing adjustment

KEEP WHEEL NUTS TIGHT

If excessive play occurs at wheel rim when wheel nuts are tight — adjust hub cone on left side of hub.

To do this:— Loosen wheelnuts and cone locknut (A) tighten adjusting cone (B), which has flat sides to take a spanner. The 'Fixed' right-hand cone must not be touched.

CORRECT HUB ADJUSTMENT — with wheelnuts tight:— A trace of side movement (play) only — at the wheel rim — none at the hub.

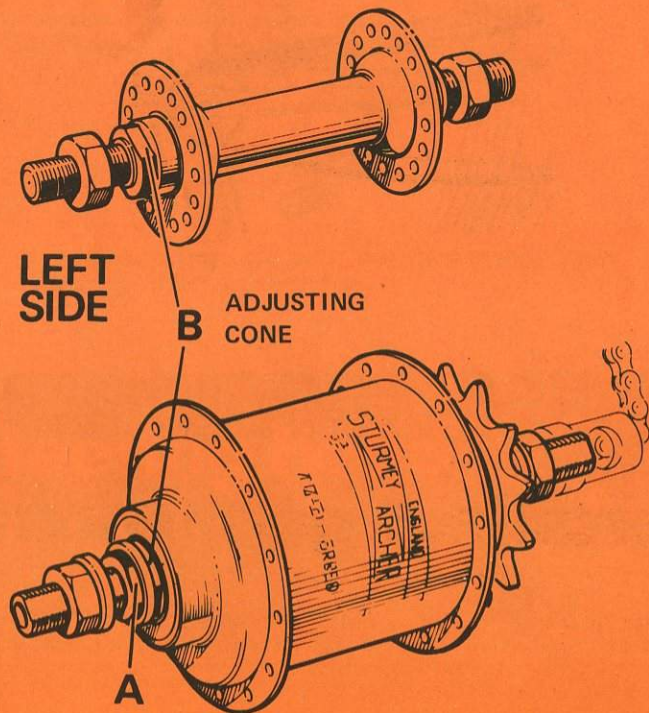

wheels

To remove **FRONT WHEEL** — loosen axle nuts (use a spanner) and lift out wheel. If you have quick-release hubs, turn quick-release lever 180 degrees. If cycle is equipped with quick-release brakes, release this unit before removing wheel.

To replace **FRONT WHEEL** — **Important:** Most front hubs have adjusting cones. The adjusting cone has flat sides and must always be on the left side. (Viewed from riding position).

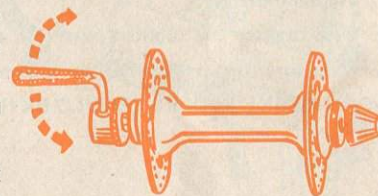

Place the wheel into the front fork — make sure the cone spigott fits inside the wide section of fork slot. Fit washers and tighten axle nuts securely. In the case of quick-release hubs, lock the lever towards the hub flange. **Note:** the quick-release lever must always be on the left side. (Viewed from the riding position).

REAR WHEEL REMOVAL — Derailleur Gear Type — change gear to high gear (i.e.) small rear sprocket. Loosen both axle nuts by turning in a counter-clockwise direction. (If your bicycle has quick-release brakes, release this unit). If equipped with quick-release hubs, turn release lever 180 degrees to free.

The wheel is now free to slide forward and out of the frame.

To replace the **REAR WHEEL** — Locate the top section of the chain on the small sprocket and fit the wheel in the frame, pushing back and centralising wheel between the chainstays — holding the wheel in this position, tighten the axle nuts in a clockwise direction. (Re-set quick-release brake unit).

adjustment of

Front

1. Loosen nut "A".
2. Raise stirrup until blocks almost touch rim.
3. Hold steady roller lever "B" and brake rod "C".
4. Tighten nut "A".
5. With brakes "on" tighten nuts "F", ensuring that blocks fit squarely to rim.
6. Make sure stirrup pegs are fully engaged in guides "D".

WORN BRAKE BLOCKS SHOULD BE REPLACED FOR YOUR OWN SAFETY.

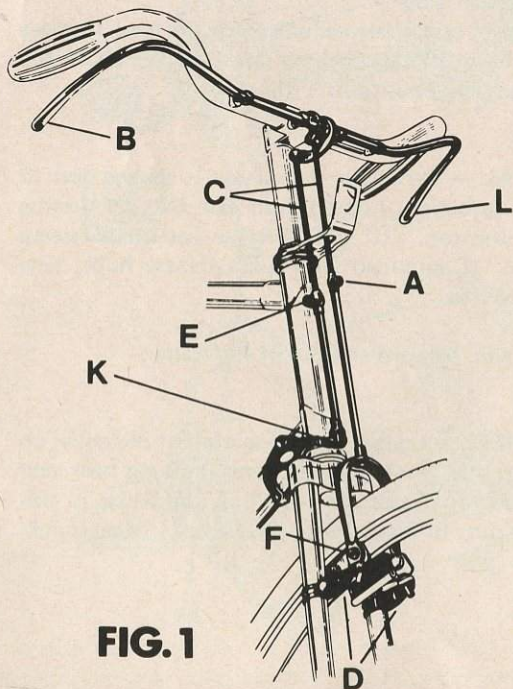

FIG. 1

roller lever brakes

Rear

1. Loosen nuts "E" and "H". Figs. 1 & 3.
2. Set bellcrank "J" until it touches bottom bracket. Fig. 3.
3. Move stirrup until blocks almost touch rim. Tighten nut "H". Fig. 3.
4. Slightly raise tube at "K", depress roller lever "L" and brake rod "C". Fig. 1.
5. Tighten nut "E".
6. With brake "on" tighten nuts "F", ensuring that blocks fit squarely to rim. Fig. 2.
7. Make sure pegs are fully engaged in guides "D". Fig. 3.

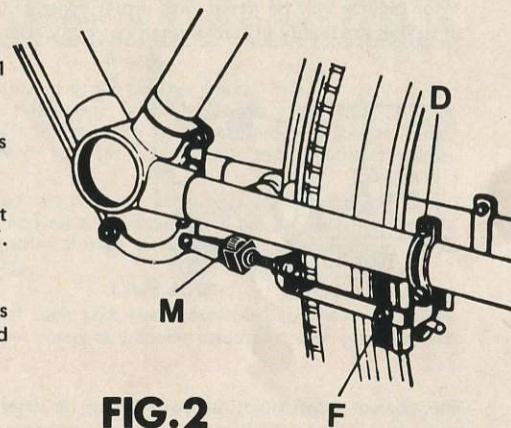

FIG. 2

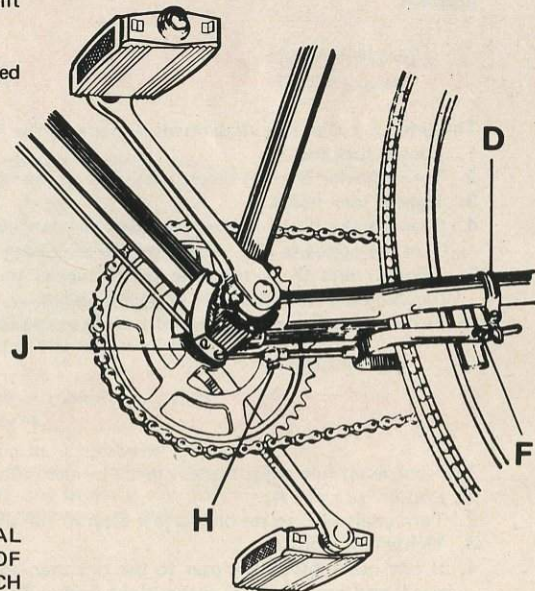
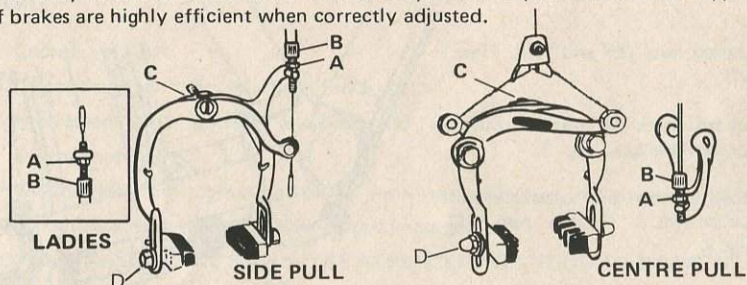

FIG. 3

ON SOME CYCLES THE FINAL ADJUSTMENT IS BY MEANS OF A KNURLED NUT "M" WHICH CAN BE ROTATED TO MOVE THE BLOCKS CLOSER TO OR AWAY FROM THE RIM. Fig. 2.

cable brakes

Your bicycle will be fitted with either centrepull or sidepull brakes. Both types of brakes are highly efficient when correctly adjusted.



brake adjustment

The correct adjustment of your brakes is when a minimum movement of the brake lever brings the brake blocks into contact with the rim. The brake should not be so closely adjusted that the brake blocks touch the rim when in the off position.

sidepull brakes

The sidepull brake fine adjustment is made by the following procedure:—

1. Loosen lock nut A.
2. Turn adjuster B to set blocks just clear of the rim.
3. Tighten lock nut A.
4. If one brake block is closer to the rim than the other, adjust this by tapping C on the opposite side. For alloy brakes loosen rear nut and recentre.
5. Tighten nuts D so that the brake blocks meet the rim squarely, and not touching the tyre when the brake is applied.

In the case of ladies' rear brakes, the cable enters the adjuster from below.

centrepull brakes

The centrepull fine adjustment is made by the following procedure:—

1. Loosen lock nut A.
2. Turn adjuster B to set blocks just clear of the rim.
3. Tighten lock nut A.
4. If one brake block is closer to the rim than the other, loosen the centre bolt nut C and centralise the entire brake body. Then tighten nut C.
5. Tighten nuts D so that the brake blocks meet the rim squarely and not touching the tyre when the brake is applied.

brake levers

The position of any brake lever should not be altered by force. The clip fixing screw should always be loosened to re-position the lever. If your brake lever works loose on the handlebar, a screwdriver can be used to tighten the clip. On hooded levers (where the securing screw is not visible) the following procedure should be adopted:—

1. Disconnect cable at the relevant brake calliper (page 16).
2. Pull lever down to the handlebar and disconnect inner cable nipple from the brake lever. The clamping screw is now accessible inside the hood.
3. Make necessary adjustment to the brake lever and reconnect cable.

IMPORTANT

Before riding check that the brake is re-set correctly and the cable clamp bolts tightened securely. (Campagnolo requires a Campagnolo T handle socket wrench). Worn brake blocks and frayed cables should be replaced immediately — FOR YOUR OWN SAFETY.

Note:

The cable brake shoes are closed at each end, the shoes must NOT be opened to replace the brake blocks. Complete shoes and block assemblies are available for replacement purposes.

quick-release brake mechanism

Quick-Release Hand Lever



Some brake levers are fitted with quick-release units (mentioned in wheel fitting). This quick-release allows you to open the brake stirrups further than normal and allows removal and fitting of the wheels. The tyre will pass through the brake blocks without deflating.

To operate the quick-release, gently apply pressure to the brake lever and press the quick-release knob with your thumb. Holding knob, allow the brake lever to return past its normal position.

The quick-release hand lever unit automatically resets itself as soon as you use your brakes.

Campagnolo brakes are fitted with a different type quick-release lever, located on the side of the brake stirrup. When the lever is down, the brake is set. To use your quick-release unit, it is necessary to pull the lever up.

Campagnolo



IMPORTANT — BEFORE RIDING, MAKE SURE THAT THE LEVER IS PUSHED DOWN OTHERWISE YOUR BRAKE WILL NOT OPERATE.

hub brake adjustment

NOTE. It is essential that the clip "C" which secures brake arm to frame or fork, is kept tight. A loose clip will reduce efficiency of brake.

ROD CONTROL TYPE

TO ADJUST, tighten adjuster nut "D" until brake linings are in contact with hub drum, then slacken until wheel revolves freely.

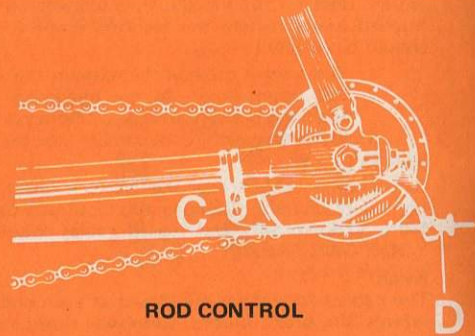

ROD CONTROL

CABLE CONTROL TYPE

The locknut "A" must be loosened before adjuster "B" is moved. Tighten locknut "A" after adjustment.

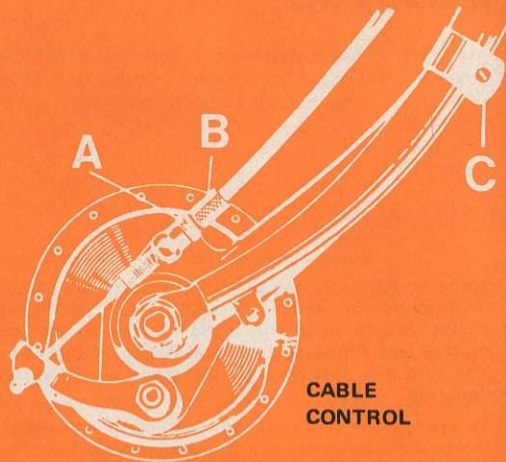

CABLE CONTROL

CABLE CONTROL



tyres

There are two basic types of tyres.

- The **standard** or wire bead type with replaceable tube, normally found on touring cycles.
- The **tubular** with tube completely enclosed, primarily used on track and road racing cycles.



The exclusive "RALEIGH" range of wire-edged tyres has been specially developed to ensure free running with safety and comfort.

TO OBTAIN MAXIMUM LIFE AND FULL BENEFIT FROM YOUR TYRES IT IS ESSENTIAL TO MAINTAIN THE RECOMMENDED PRESSURE INDICATED ON THE TYRE.

Most innertubes are fitted with car type (Schrader) valves and can be inflated by a bicycle hand pump, fitted with the appropriate connector, or by the use of a car foot pump. Due to the possibility of over inflation the use of garage air lines is **not** recommended.

Use your brakes with intelligent anticipation — unnecessarily hard braking greatly reduces tyre life. Make sure your tyres do not come into contact with oil, petrol (gasoline) paraffin (kerosene) Naptha or other rubber solvents.

Buying new Tyres or Tubes

To ensure satisfactory service, always fit the "RALEIGH" brand.

Make sure you obtain the correct size. Sizes are clearly marked on the rim of each wheel and on tyres and tubes. **ALL THREE MUST AGREE — RIM — TUBE AND TYRE.**

tyre changing

- (a) **STANDARD** — wire edged tyre — to remove: completely deflate tube and **push tyre edges to centre of rim**. Take a tyre lever and wedge it carefully under the edge of tyre near the valve and lift edge over rim. Hook handle of lever under a spoke to hold. Using other tyre levers, work your way around until one side of tyre is off. Use caution not to catch tube between lever and tyre or rim. Also, do not use sharp edged tools in lieu of the blunt tyre levers. Remove tube.

To repair a puncture: use tube repair kit and follow instructions supplied with kit.

To replace tyre: first make sure that the rim tape (narrow band of cotton or rubber that surrounds rim to protect tube from spoke ends) is in place in centre of rim.

Fit one side of tyre on wheel and push tube valve through valve hole. Inflate tube slightly and place carefully in tyre. Starting from valve hole, work second side of the tyre over rim, using fingers and thumbs only. Work from both sides away from valve, push tyre edges to centre of rim until tyre is on rim. Inflate slowly making sure tyre is sitting squarely on shoulders of the rim. (**Never use tools to replace tyre on rim**).

Note

Inflate to the recommended pressure indicated on the tyre. Remember to fit valve sealing cap after inflating tyre.

- (b) **TUBULAR** — to remove: simply deflate and work off the rim with hands.

To replace tyre: since tubular tyres must be cemented to rims, the rim first should be cleaned with a solvent. When cleaning, check spoke ends to see that they are level with nipple heads — not above.

Apply a layer of rim cement evenly with your finger or a small brush in the well of the rim — make sure you do not get cement on outside braking surface of rim.

Inflate tubular tyre until it turns inside out and apply a thin layer of cement to the base tape.

When cement becomes tacky, reduce pressure until the tyre will just hold its shape then proceed to fit tyre as shown.

Note

Inflate **tubular tyres** to at least 90 pounds per square inch. For best performance and longer wear, it is best to partially deflate tubular tyres after each day's use and inflate again before riding.

Remember to fit the valve sealing cap after inflating tyres.

changing tubular tyres



1. Stand wheel in upright position — insert valve through valve hole in rim.

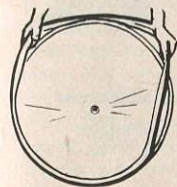

2. Holding tyre firmly on both sides — stretch by pushing downward and work into position on rim.

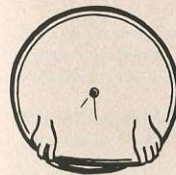

3. Continue process as far as possible working to side of rim opposite valve.



4. Lift to horizontal position and stretch remaining portion into place — clean your hands.

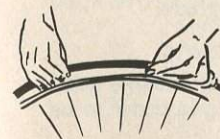

5. Inflate tyre further and seat correctly on rim — true by rolling in proper direction. If there are high or low spots, stretch the tyre where there are high spots — push together where there are low spots. Now fully inflate tyre. It is advisable to allow 12 hours for drying before riding.

derailleur gear

It is so named because it works on a derailing principle of moving the chain from one sprocket to another. The number of gears is determined by multiplying the number of sprockets on the free (rear) wheel and the number of chainrings on the chain wheel.

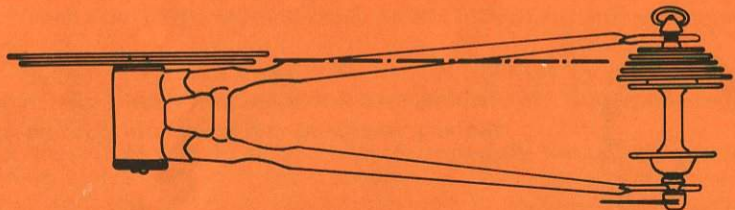

The wide range of gears allows you to combat all prevailing conditions while pedaling at the comfortable rate of 60 revolutions per minute. The rate and gear ratios have been scientifically determined so all you need do is select the gear that suits the road conditions.

RULES FOR CHANGING GEARS

1. THE PEDALS MUST BE KEPT TURNING WHEN CHANGING GEAR

The only way the chain can be carried from one sprocket to another is for it to be moving in a forward direction, so never stop pedaling when changing gear. Never attempt to change gear when back pedaling.

2. IT IS NOT NECESSARY TO USE ALL GEARS IN SEQUENCE

Select the gear that is most comfortable for the road grade.

3. GEAR SELECTION SHOULD BE MADE IN ADVANCE

Since forward speed must be maintained in order to change gear, it's a good idea to shift to a lower gear before stopping in order to be in the proper gear again when you start.

gear change levers

There are two levers. The lever left controls the chainwheel shifter ... the one on the right controls the free (rear) wheel shifter. Both operate with finger-tip control. Shift firmly and smoothly.

The left lever controls only two gear positions and should be moved either all the way forward or all the way back.

The right lever controls several gear positions and they are felt, rather than selected by a positive position. (When changing from one gear to another, if the chain clatters this can be corrected by a slight additional movement of the lever). At first this may seem difficult, but with practice it will become automatic. The system was designed for safety. You can keep your eyes on the road while shifting.



Levers should be tight enough to hold gear, otherwise tighten the tension lever wing-type screws on the side of each lever.

DO NOT LUBRICATE! This lever works on friction which keeps lever from shifting by itself.

Chopper model — 5-speed derailleur console gear shift.

Note: To increase tension on the T bar gear control lever, push forward the small right hand lever as required until the T bar lever holds the gear unit in all gear positions.

Lever position

5-SPEED high gear — lever in most forward position — bottom gear — lever in most backward position.

10-SPEED left hand lever operates front changer to move the chain over chainwheels. Right hand lever operates gear mechanism and moves chain across sprockets.

Chain on large chainwheel and small sprocket = highest gear
i.e. Left hand lever in backward position
Right hand lever in forward position

Chain on small chainwheel and large sprocket = lowest gear
i.e. Left hand lever in forward position
Right hand lever in backward position.

derailleur gear adjustment

You should return your cycle to your dealer for adjustments. However, in case of emergency and for minor adjustments, the fault finding chart should help you. It is recommended that you work in the order given here.

Depending on the model you own, your cycle will be fitted with one of four different kinds of gears. Since they all operate on the same principle, the adjustment is basically the same.

1. Turn cycle over standing it on handlebar and saddle (protect handlebar and saddle from damage).
2. Rotate pedals to turn rear wheel and operate all gears to determine your problem. (Use chart for reference).

cable adjustment

1. Rotating pedals, shift both levers forward (natural position with chain on small chain wheel and sprocket).
2. Check cable tension. Properly adjusted, cables should have a small amount of play.
3. To adjust, release cable clamp bolt C then pull cable tighter with a pair of pliers and retighten clamp bolt.

(see illustrations on page 16).

gear maintenance

To help ensure that your Derailleur gear works efficiently and to prolong its life, it must be kept clean of excess oil and condensation and properly lubricated.

finding & correcting problems

REAR MECHANISM

<i>Problem</i>	<i>Cause</i>	<i>Cure & Comments</i>
1. Changing from gear selected without touching shift lever.	(1) Incorrect tension on gear change lever. (2) Cable slip.	Tighten gear tension lever screw. Do not over tighten so that you are unable to change gear. Do not lubricate — as lever works on friction. Tighten cable pinch bolt. Ensure cable adjustment is correct before tightening.
2. Chain throws off the small sprocket toward frame — or not riding on or reaching small sprocket.	(1) Incorrect setting of high gear adjustment screw.	Readjust. Ensure that tension in gear cable does not act as a stop.
3. Chain throws off the large sprocket toward wheel or not riding on or reaching the large sprocket.	(1) Incorrect setting of low gear adjustment screw.	Readjust. Ensure that the chain never derails toward the wheel, as extensive damage can occur.
4. Gear lever engages lever stop before low gear is obtained.	(1) Too much slack in cable.	Readjust cable. Ensure cable does not act as a stop.

FRONT MECHANISM

1. Changing — from large to small chain wheel without touching shift lever.	(1) Incorrect tension on gear change levers.	Tighten gear tension lever screw. Do not over tighten so that you are unable to change gear. Do not lubricate as lever works on friction.
2. Chain throwing off large chain wheel or not engaging chainwheel.	(1) Incorrect setting of outer chainwheel adjustment screw.	Readjust.
3. Chain throwing off small chainwheel or not engaging chainwheel.	(1) Incorrect setting of inner chainwheel adjustment screw.	Readjust.

If problems continue to arise, take your cycle to the dealer for additional adjustments.

derailleur gear front changer

1. While turning pedals move the right hand lever back changing to middle sprocket. Move the left hand lever forward changing to small chain wheel.
2. The chain should be in the middle of the derailleur cage. If not, adjust as follows:—
 - (a) On Huret and Campagnolo gears use adjusting screws 'A' and 'B' to limit movement of cage. Turn clockwise to decrease movement and counterclockwise to increase movement.
 - (b) On Simplex gears, loosen set screw 'A' and slide cage by hand until centred -- retighten set screw. **IMPORTANT, DO NOT OVER TIGHTEN.** Screw 'B' is outward limit screw.
3. Turn pedals and shift to large chainwheel (left lever). If chain does not shift, place chain on large chainwheel by hand and re-centre the cage.

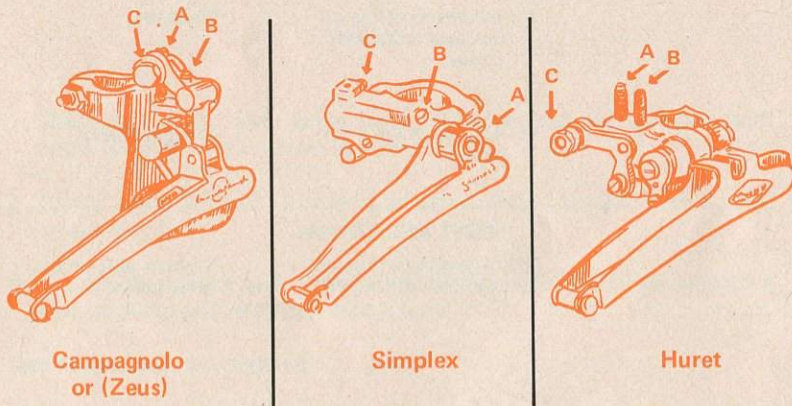

Campagnolo or (Zeus)

Simplex

Huret

Position of Derailleur Gear Front Changer

The vertical position of the changer is set correctly at the factory. If the front changer has been removed re-fit carefully; the changer plates must be parallel to the chainwheel and set vertically so that the lower edge of the outer plate of the cage is $\frac{3}{8}$ " above the larger chainwheel teeth.

adjustment of rear derailleur gear

1. While turning pedals move right-hand lever backwards and change to second largest sprocket.
2. Still turning pedals gently, try to shift to the largest sprocket.
 - (a) If you are unable to shift onto this sprocket, turn adjusting screw B counter-clockwise until the chain moves to the largest sprocket.
 - (b) If you can shift to the largest sprocket and continued movement of the shifting lever causes the chain to override ... then turn screw B clockwise until the shifting lever stops with the chain in the correct position on the largest sprocket.
3. Gently move lever forward until you have shifted to next sprocket.
4. To adjust shifting of the chain to the smallest sprocket, follow generally the procedure outlined in No. 2 above, using screw A.

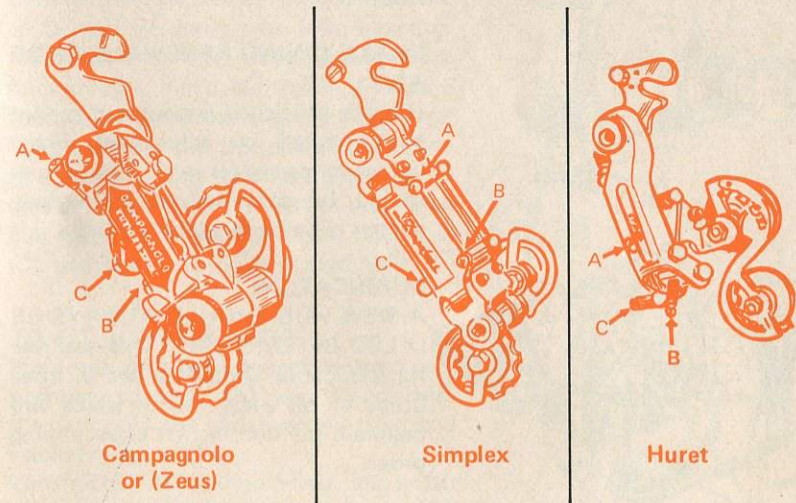

Campagnolo or (Zeus)

Simplex

Huret

Screw "A" limits the outward movement of the gear unit
 Screw "B" limits the inward movement of the gear unit
 Screw "C" is the cable clamp bolt

maintenance & adjustment of sturmey-archer gears

BEARING ADJUSTMENT — ALL HUBS

The right-hand cone is fixed at factory and should not be touched. Bearings are adjusted by loosening left-hand locknut "A" and rotating cone "B", care being taken to re-tighten locknut afterwards.

A CORRECTLY ADJUSTED WHEEL SHOULD RUN FREELY WITH A TRACE OF SIDE MOVEMENT ONLY AT THE WHEEL RIM.

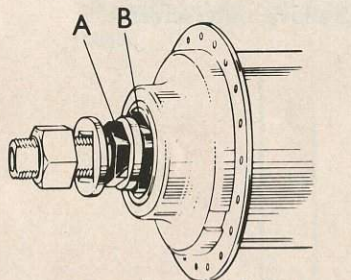

In the case of hub brakes BF, BR & AB — a slotted cone adjusting washer is placed over the cone. This should be rotated to obtain correct adjustment as above.

BRAKE LINING RENEWALS, BF BR AB

If brake efficiency is poor and cannot be corrected by adjustment, brake linings may need renewal. Your dealer should be consulted as a Sturmey-Archer re-lining service is available.

LUBRICATION

A NEW HUB SHOULD ALWAYS BE OILED BEFORE USE. The ideal rule for lubrication should be two or three drops of oil every month which will maintain the hub in first class running order.

3-SPEED COASTER BRAKE S3C

Lubrication of gear automatically provides for the brake mechanism. No other attention is necessary.

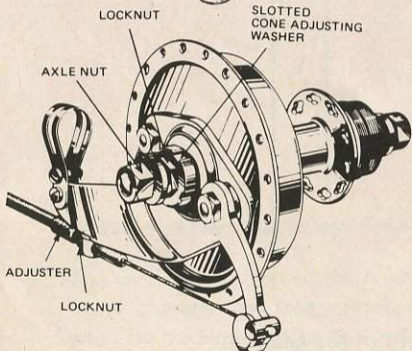

trigger control

TO FIT TRIGGER CONTROL

1. Open clip and place control approximately 2" from end of handlebar grip and secure fixing screw.
2. Pass cable inner wire through fulcrum clip and into clip slot — (then over pulley wheel, if fitted).
3. Push outer cable up to fulcrum slot. Fit cable anchorage — at hub end — Push gear lever forward, tighten inner wire and secure anchorage nut firmly.
4. Connect control cable to gear indicator coupling at hub.
5. Slide fulcrum clip to take up any slackness in cable and tighten clip screw.
6. Adjust gears.

TO REMOVE THE CONTROL WIRE

It is not necessary to remove control from handlebar if the lever can be pulled back far enough to allow cable nipple to pass between pawl and ratchet plate. Procedure is: Detach the inner wire from indicator chain at hub, and outer casing from fulcrum clip. Pull cable ferrule (F) downward to remove from slot (B). Pull lever right back beyond bottom gear position to stop (A), push inner wire through to detach nipple (D) from ratchet plate then pull wire out between pawl and ratchet at (C) and finally through slotted hole (B).

TO FIT CONTROL WIRE

Pull lever right back beyond bottom gear position to stop (A) and insert wire through hole (B) and between pawl and ratchet plate at (C).

Wire nipple (D) is then fitted into notch (E) and cable ferrule (F) slotted into (B). Keeping tension on wire, push lever forward into top gear position. Control is then ready for re-connection.

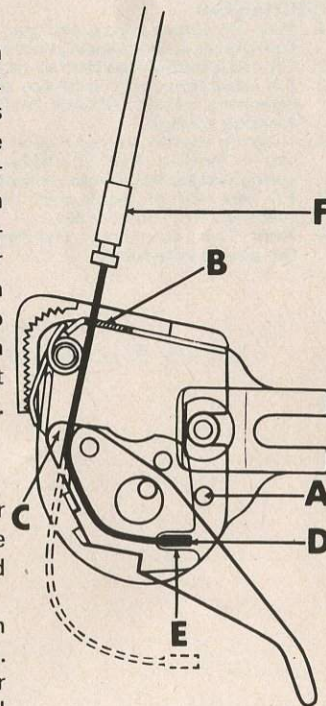

auto twist grip control

IMPORTANT — THE GRIP MUST NOT BE TWISTED UNTIL FITTED TO THE BICYCLE AND THE CABLE CONNECTED TO GEAR INDICATOR ROD AT THE HUB.

1. Slide control on to handlebar as far as possible, adjust grip to required position. Tighten — **EVENLY** — fixing screws.
2. Pass cable inner wire through fulcrum clip and into clip slot — (then over pulley wheel, if fitted).
3. Push outer cable up to fulcrum slot. Fit cable anchorage at hub end — Twist the grip forward to tighten inner wire and secure anchorage nut firmly.
4. Connect control cable to gear indicator coupling at hub.
5. Slide fulcrum clip to take up any slackness in cable and tighten clip screw.
6. Adjust gears.

TO SET GEARS AUTOMATICALLY IN ADJUSTMENT

Twist the grip until bottom gear (No. 1) is indicated (i.e. the blue coloured section can be seen through top of casing aperture) — Continue to turn grip until no further movement can be obtained. **ALL THREE GEARS ARE NOW AUTOMATICALLY IN ADJUSTMENT.**

NOTE — When all the cable adjustment has been taken up the twist grip must be dismantled and the gear locating spring refitted: See Assembly Notes.

TO RESET GEAR LOCATING SPRING AND ASSEMBLE TWIST GRIP MECHANISM

1. First fit detent spring and the 3/16" dia. ball into recess in operating sleeve — (use grease to hold spring and ball in position).
2. Fit cable nipple into slotted recess of operating sleeve.
3. Fit cable inner wire into slot of gear locating spring, and position spring over operating sleeve. (Check 3/16" dia. ball is positioned in elongated hole of locating spring).
4. Keeping thumb of right hand over ball and spring, feed inner wire into cable slot of bottom half of casing. Now press locating spring into casing — until spring is **right down** into its groove.
5. Fit top half of casing over operating sleeve. Holding two halves of casing together, fit clamp screws.
6. Refit Twist Grip on to Handlebar, and take up all slackness in Control Cable. Set gears as described.

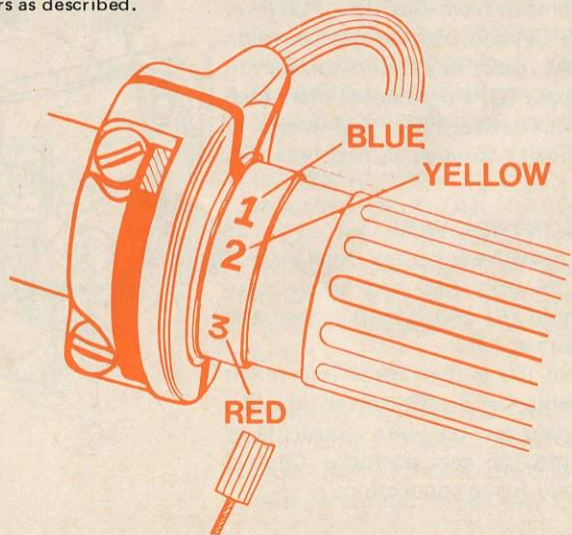

replacement of gear cable 'sportshift' control

To Remove Old Cable

1. Detach control unit from bicycle. Unscrew cable connector from gear indicator coupling — at hub end.
2. Remove front screw from underside of control unit fixing plate.
3. Unscrew lever knob and remove from lever, lift off plastic cover and push lever forward. Use a screwdriver to prise cable ferrule from its recess.
N.B. If your 'Sportshift' has gear indication with a mechanical linkage and cursor plate, gently ease plastic cursor plate from its retaining pegs and swing to right side to reveal cable ferrule.
4. From underside of base plate, use a small screwdriver to push cable nipple from recess.

To Fit New Cable

5. Fit inner wire nipple and outer cable ferrule into recess: see diagram — the domed end of inner wire nipple must face upwards.
(Note: Refit cursor plate onto its securing pegs).
6. Replace plastic cover and lever knob. Refit control unit to bicycle.
7. Pass inner wire through fulcrum clip — on rear frame tube — and fit wire into clip slot.
8. Connect cable to hub end.
9. Set gears as described. See page 29.

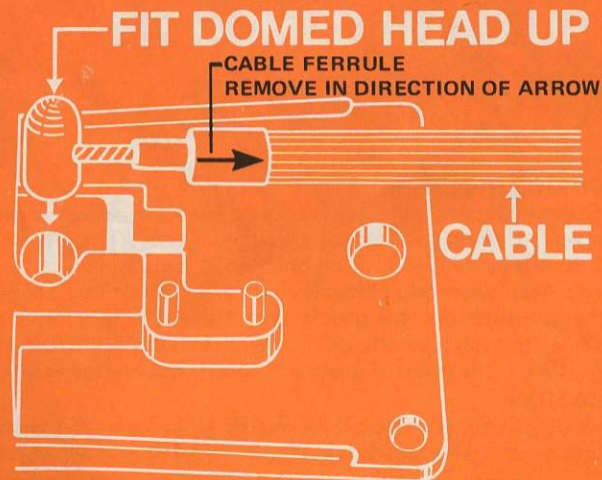

sturmey-archer 3-speed hub gear

THE IMPORTANCE OF CORRECT GEAR ADJUSTMENT

Correctly adjusted, Sturmey-Archer gears will give you years of trouble-free cycling. If however they are not adjusted correctly they will not function properly and 'slipping' will occur and this will result in permanent damage, unless corrected promptly.

GEAR ADJUSTMENT

First place the gear control in No. 2 position. Then screw the cable connector (3) until **THE END OF THE INDICATOR ROD IS EXACTLY LEVEL WITH THE EXTREME END OF THE AXLE.** This can be seen through 'window' in the right-hand nut, see (1) — Now tighten locknut (2). All Gears are now set.

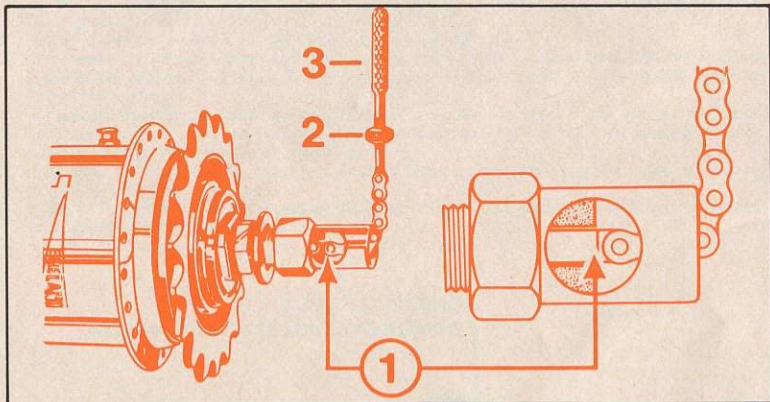

GEAR CHANGING

In use, Sturmey-Archer variable gear hubs have the easiest, cleanest and most convenient means of making a change of gear. The change may be made whilst the cycle is in motion or when it is stationary.

To change gear when the bicycle is moving, continue to pedal but EASE the pressure on the pedals and move the gear lever smartly. Should it be necessary to change gear whilst stationary EASE PEDALS BACKWARDS — the internal gears will rotate and engage easily.

LUBRICATION

A NEW HUB MUST BE OILED BEFORE USE through the lubricator on the hub shell. Afterwards add one or two drops of oil at least every month.

maintenance of sturmey-archer SC coaster hub

IMPORTANT the following simple instructions covering **ADJUSTMENT AND LUBRICATION** should be followed to ensure that the SC hub, (which is fitted with a powerful brake unaffected by all weather conditions) may operate efficiently.

The Hub bearings can be adjusted without removing the wheel from the bicycle.

1. Loosen the two axle nuts "A".
2. Loosen the locknut on the left-hand side of the wheel "B".
3. Place the special spanner on the square end of the axle "C", turn it clockwise to tighten the bearings or anti-clockwise to loosen them.
4. Re-tighten the locknut and axle nuts leaving the wheel with just a trace of side-play at the rim.

If for any reason it is necessary to remove the rear wheel from the bicycle, it is most important that the brake arm clip is **TIGHTENED SECURELY** when the wheel is refitted.

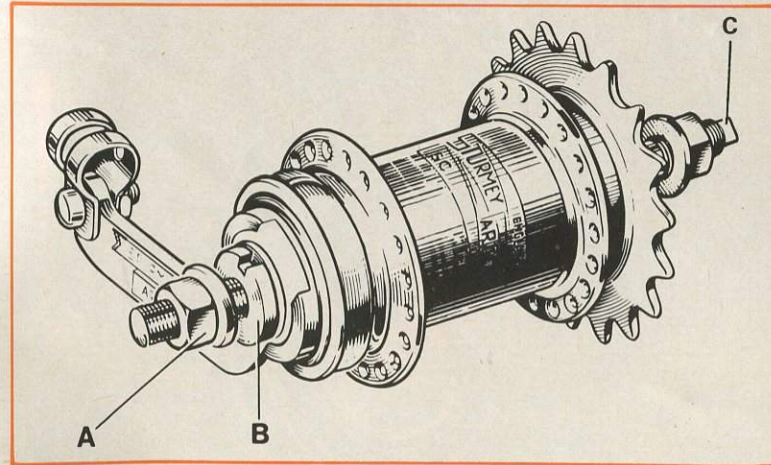

To maintain this Hub in good running condition, we recommend the specially blended high grade STURMEY ARCHER or RALEIGH INDUSTRIES "ALL-PURPOSE" lubricants.

dynohub bearing adjustment

A correctly adjusted wheel has a trace of side movement only at wheel rim — none at the hub.

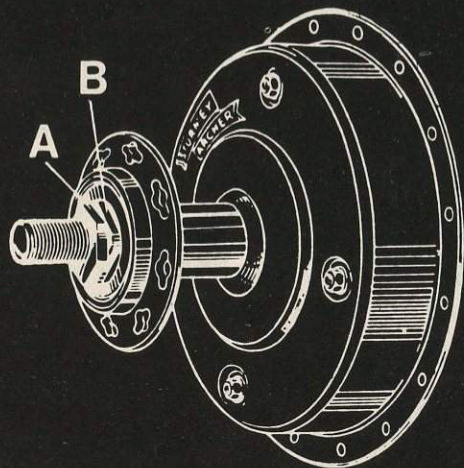

Front 'Dynohub' (GH6) is adjusted on left side (away) from dynamo by loosening locknut "A" and adjusting cone "B".

Rear 'Dynohub' (AG) is adjusted on left side (dynamo side). Loosen locknut "A" and adjust slotted washer "B".

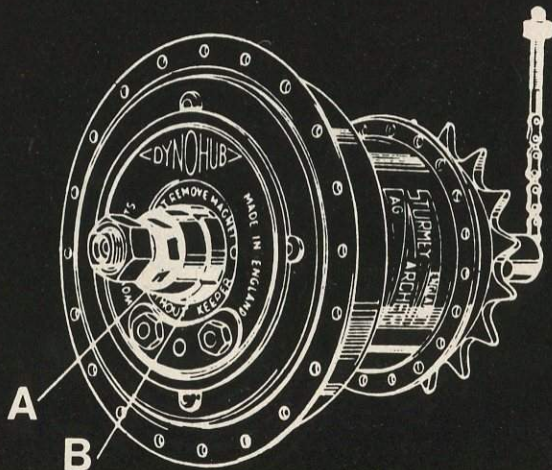

sturmey-archer 'dynohub' hub lighting equipment

Servicing of this equipment is a job for the expert, but a few hints may prevent trouble.

1. Never remove armature from magnet. De-magnetising will occur even during a very short separation.
2. See that all terminals are secure and clean.
3. Use correctly rated bulbs at all times —
Steel Headlamp — 6v.2 amp — M.E.S.
Plastic Headlamp — 6v.2 amp — Capless type
Rear Lamp — 6v.1 amp — Capless type
4. Always loosen fixing bolt before altering headlamp angle.
5. Never leave run-down batteries in Dry Battery Unit (D.B.U.) or Filter Switch Unit (F.S.U.) casings, or corrosion will occur.
6. Keep retaining spring in groove in battery container clean. A smear of grease will prevent corrosion.



tyre driven lighting



To operate the dynamo: Press the lever marked 12. To disengage, pull the dynamo body back until the lock catches.



The rotating part of the dynamo should contact the sidewall of the tyre, flatly and firmly.

To replace headlamp bulb: undo screw and remove top half of lamp body. Pull bulb holder from reflector unit, and unscrew the bulb. Replace bulb with screw type 6 volt, 2.4 watt, 4 amp.

To replace rear lamp bulb: unscrew red lens and unscrew bulb from holder. Replace bulb with screw type 6 volt, 6 watt, 1 amp.

holdalls and carriers

R.20 HOLDALL

(1) To secure the R.20 holdall to the plastic luggage tray — push the ball ends of the rubber straps **right through** the circular ends of the 'keyhole' shaped slots in the tray end flanges.

Note. The straps must be pulled sideways to secure them in the narrow section of 'keyhole' slots.

(2) When fitting the holdall into its plastic tray, ensure that both rubber bands are fastened to the hooks on the holdall carrying strap.

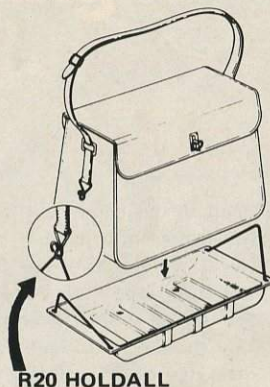

R20 HOLDALL

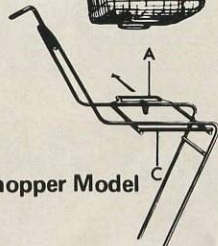

R20 Shopper Model

TWENTY & RSW MODELS

TO REMOVE CARRIER BASKET or HOLDALL from the bicycle simply pull the quick release handle 'A' in the direction indicated, and lift away.

TO REFIT CARRIER BASKET or HOLDALL — pull the quick release handle 'A' as indicated and lower the Basket or Holdall into position, locating side mounting plate under bar 'C' of carrier.

The release handle 'A' will automatically locate over the side of mounting plate, when released, locking the Basket or Holdall in position.

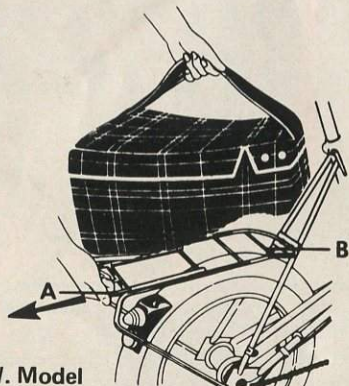

R.S.W. Model

folding models



TO FOLD — Loosen Lockring Lever and swing Front of bicycle anti-clockwise (in direction of arrow) to bring the front wheel alongside the rear wheel.

Cycle Identification Form

You should complete this form and keep it safely for production to the police should your cycle be lost or stolen.

Owner's Name

Address

Lady's or Gent's

*Cycle Serial No.

Make and Frame Size

Colour Cycle Lock Key No.....

Other Details

* The Cycle serial number is located either:

- (1) On the seat lug.
- (2) The left side chainstay end of the rear fork, just above the rear wheel axle.
- (3) Under the bottom bracket.

INTERNATIONAL CYCLE WARRANTY

Raleigh products are the result of many years of research and development and are designed and built to the highest standard.

Raleigh guarantee its products against any defect in workmanship or material provided the product has not been damaged by accident, abuse, alteration, or misuse.

In offering this guarantee Raleigh in no way seeks to diminish or restrict the statutory rights of a purchaser of any of its products.



TI RALEIGH LIMITED

ENGLAND

County	Dealer	Tel. no.
West Midlands	Criterion Cycles, (Dudley Ltd.,) King Street, Dudley	0384 53950
	Geo. Dugmore Ltd., 249-261 Bilston Road, Wolverhampton	0902 52313
	T. Godwin, 10-12 Silver Street, Kings Heath, Birmingham 14	021 444 2592
	W. Swift & Sons Ltd., 436 Foleshill Road, Coventry	0203 88387
	Reg Tedstill, 3 Rookery Street, Wednesfield, Wolverhampton	0902 732823
Wiltshire	C.T. Haines & Son, Stonehenge Cycle Co., Water Lane, Salisbury	0722 4915
	David Large Cycles, 3 Whitehouse Road, Swindon	0793 36657
Worcester	Eric Williams Ltd., Pierpoint Street, Worcester	0905 25786
Yorkshire North	Brian Shannon, 171 Boroughbridge Road, York YO2 6AN	0904 791610
Yorkshire South	Allens, 428 Firth Park Road, Firth Park, Sheffield 5	0742 386742
	Allens, 642 Staniforth Road, Darnall, Sheffield 9	0742 446576
	Allens (Branch), 23 Barnsley Road, Wombwell, Barnsley	0226 756281
	J. Foster Cycles, 112 College Road, Rotherham	0709 78068
	Henry Holmes Ltd., 337 London Road, Sheffield 2	0742 51423
	J. Turton, 127 Balby Road, Doncaster	0302 27663
Yorkshire West	Geoff Clark Cycles, 115 Arncliffe Terrace, Bradford 7	0274 73956
	Doug Hartley, 277 Dewsbury Road, Wakefield	0924 63148
	Leslie Swaine, 15 The Green, Idle, Bradford	0274 611590
	Woodrup Cycles, 345-7 Kirkstall Road, Leeds 4	0532 636212

SCOTLAND

Churchills (Prms) Ltd., 90-92 Commerce Street, Glasgow	041 429 3781
R. & M. Dorricott, Market Square, Inverberrie, Kincardineshire	056 16 208
J.B. Duff, 460 George Street, Aberdeen	0224 22994
Finnies Sports & Cycle Centre, 40 Newmarket Street, Ayr	0292 82368
A. Junner & Co. Ltd., 36-38 Batcher Street, Elgin, Morayshire	Elgin 2492
A. Junner & Co. Ltd., 14-16 Greig Street, Inverness	0463 36704
W. & R. MacDonald, 26 Morrison Street, Edinburgh 3	031 229 8473
McLennan (Cycle Shop), 32 Cromwell Street, Stornaway, Isle of Lewis	0851 2202
J.M. Richard, 44 George Street, Perth	0738 26860

WALES

Claude Crimes, 8-10 Station Road, Queensferry	024 451 2554
Hughes Cycles, 20 Bodfor Street, Rhyl	0745 2012
Reg Braddick & Sons Ltd., 59-61 The Broadway, Cardiff	0222 490137
Kennards Ltd., 195-201 Richmond Road, Cardiff	0222 22131

Additionally, any Halfords Branch would be pleased to assist you in arranging for your Raleigh Bicycle or Toy to be serviced.

ENGLAND

County	Dealer	Tel. no.
Avon	Fred Baker Cycles, 144 Cheltenham Road, Bristol 6	0272 49610
	Filmac's, 14 Gloucester Road North, Filton Park, Bristol	0272 692158
	J.C. Hare Ltd., 30 Moorland Road, Oldfield Park, Bath	0225 22674
	Harvey's Cycle Exchange, 178 Henleaze Road, Bristol	0272 628330
	Fred Palmer, 11-13 Stokes Croft, Bristol	0272 49550
	Shirehampton Pram & Toy Centre, High St., Shirehampton Bristol	02752 5672
Bedfordshire	D.J. Levitt, 288 Dunstable Road, Luton	0582 27511
Buckhamshire	Bakers Stores, 21 Buckingham Street, Aylesbury	0296 82077
Cambdeshire	Colton Cycles Ltd., 70 Westgate, Peterborough	0733 66341
Cheshire	Claude Crimes, 38 Bridge Street, Chester	0244 22177
	Doug Hartley, 100 Ashley Road, Hale	061 928 1987
Cumbria	K. Whitehead & Son, 104-106 Botchergate, Carlisle	0228 26890
Derbyshire	Samway, 70A Friargate, Derby	96 368849
Devon	Battery Cycle Works, 125 Embankment Road, Plymouth	0752 65553
	The Tower Motor Cycles & Bicycles (N.A.) Ltd., Wolborough Street, Newton Abbot	0626 2942
	C. Webber, 50 Bear Street, Barnstaple	0271 3277
Dorset	Harveys Ltd., 58 Poole Road, Bournemouth	0202 761550
Essex	J.D. Prentice & Son Ltd., 1 London Road, Wickford	03744 2333
	R.D. Wheeler, 23 Military Road, Colchester	0206 73404
Gloucstrshire	T.G. Hall, 25 Barton Street, Gloucester	0452 23196
Hampshire	E. Field, Reading Road Cycles Stores, Fleet	02514 6340
	Bim Osborne, 80 Gregson Avenue, Bridgemary	032 92 80181
Hertfrdshire	A.J. Haddow, The Wynd, Letchworth	046 26 3615
	N.J. Thake, 105 London Road, Sawbridgeworth	0279 722853
Humberside North	Len Corden & Son, 4 Southcoats Lane, Hull	0482 74505
	Cliff Pratt Ltd., 84 Spring Bank, Hull	0482 228293
Humberside South	Bennetts, 70 Frodingham Road, Scunthorpe	0724 2042
	S.W. Dine, 9 Waltham Road, Scartho, Grimsby	0472 77462
Isle of Man	Charles Turner Ltd., 47 Strand Street, Douglas	0624 4444
Kent	W. Jones & Sons, Chart Road Industrial Estate, Ashford	0233 20415
	George Lawrence (Cycles) Ltd., 1 Trinity Hill, Margate	0843 23038
	O.T. Cycles, Rear of 79 East Hill, Dartford	0322 74006
	Canterbury Cycle Mart, 22-24 Stour Street, Canterbury	0227 61488

ENGLAND

County	Dealer	Tel. no.
Lancashire	Broadgate Cycles Co., 45 Fishergate Hill, Preston	0772 51612
	J. Partington, 11 Great Moor Street, Bolton	0204 24449
	Rogersons, Orrell Post, Wigan	0942 214 437
	Smalleys, 28-30 Parliament Street, Lancaster (Branches at Alexandra Bldgs, Lancaster & 104 Euston Road, Morecambe)	0524 63478
	Sam Taylor, 11-17 Vicarage Lane, Marton, Blackpool	0253 63442
	Eric Wilson (Cycles), 56 Bank Street, Rawtenstall	070 62 6687
Leicestershire	Leedhams & Son, 3-5 Narborough Road, Leicester	0533 549356
Lincolnshire	Binks Cycles Ltd., 365 High Street, Lincoln	0522 27070
London Area	E. Chamberlaine & Sons Ltd., 71/77 Kentish Town Rd., N.W.1	01 485 3983
	Days Cycles, 570 Lordship Lane, Wood Green, N. 22	01 888 2686
	Days Cycles (Branch), 104 Hornsey High St., Hornsey N.8	01 348 1644
	Northwood Cycle Depot, 138 Pinner Road, Northwood, Middx	092 74 24174
	W.S. Patching & Son Ltd., 43 Walton Road, East Molesey, Surrey	01 979 1689
	Smith Bros., 14 Church Road, Wimbledon, S.W.19	01 946 2270
	Toplis Engineering Ltd., 19 Ravenswood Crescent, West Wickham, Kent	01 777 1084
Merseyside	Longworths, 256 Wallasey Village, Wallasey	051 639 4225
	Oban Cycles, 109 Breck Road, Anfield, Liverpool 4	051 263 6332
	W.V. Shallcross Ltd., 151-157 Laird Street, Birkenhead	051 652 2978
	Walvale Cycle Co., 58 Walton Vale, Liverpool 9	051 525 6189
Norfolk	Mayhews Ltd., 54 West End Street, Norwich	0603 26660
Northntshire	Newlec Cycles, 119 St. James Road, Northampton	0604 51996
Nottmshire	J. Fletcher & Son, 58 Station Street, Mansfield Woodhouse	91 21072
	W. Phillips, 29-31 Cromford Road, Langley Mill	941 3755
	G.L.F. Read, 105 Victoria Road, Netherfield	0602 248760
Oxfordshire	Dentons Cycles, 294 Banbury Road, Oxford	0865 53859
	Dentons (Branch), 1 High Street, Witney	0993 4979
Somerset	Ralph Colman, 79 Station Road, Taunton	0823 5822
Staffordshire	Brookfields Toyland Ltd., Trentham Road, Longton, Stoke-on-Trent	0782 319414
Suffolk	A. & H. Elmy, 62-64, St. Helens Street, Ipswich	0473 55247
	Moons Cycle Depot, 85 High Street, Newmarket	0638 3147
Sussex West	E.H. Gammans & Son, Gordon Road, Shoreham-by-Sea	079 17 2445
	Anthony Hole & Sons, 50 Church Road, Burgess Hill	044 46 3176
Tyne & Wear	Lionel Clark, 5 Saville Street West, North Shields	089 45 75012
	Davy Tree & Co., 166 Heaton Road, Newcastle-upon-Tyne 6	0632 655870

ENGLAND

County	Dealer	Tel. no.
West Midlands	Criterion Cycles, (Dudley Ltd.,) King Street, Dudley	0384 53950
	Geo. Dugmore Ltd., 249-261 Bilston Road, Wolverhampton	0902 52313
	T. Godwin, 10-12 Silver Street, Kings Heath, Birmingham 14	021 444 2592
	W. Swift & Sons Ltd., 436 Foleshill Road, Coventry	0203 88387
	Reg Tedstill, 3 Rookery Street, Wednesfield, Wolverhampton	0902 732823
Wiltshire	C.T. Haines & Son, Stonehenge Cycle Co., Water Lane, Salisbury	0722 4915
	David Large Cycles, 3 Whitehouse Road, Swindon	0793 36657
Worcester	Eric Williams Ltd., Pierpoint Street, Worcester	0905 25786
Yorkshire North	Brian Shannon, 171 Boroughbridge Road, York YO2 6AN	0904 791610
Yorkshire South	Allens, 428 Firth Park Road, Firth Park, Sheffield 5	0742 386742
	Allens, 642 Staniforth Road, Darnall, Sheffield 9	0742 446576
	Allens (Branch), 23 Barnsley Road, Wombwell, Barnsley	0226 756281
	J. Foster Cycles, 112 College Road, Rotherham	0709 78068
	Henry Holmes Ltd., 337 London Road, Sheffield 2	0742 51423
	J. Turton, 127 Balby Road, Doncaster	0302 27663
Yorkshire West	Geoff Clark Cycles, 115 Arncliffe Terrace, Bradford 7	0274 73956
	Doug Hartley, 277 Dewsbury Road, Wakefield	0924 63148
	Leslie Swaine, 15 The Green, Idle, Bradford	0274 611590
	Woodrup Cycles, 345-7 Kirkstall Road, Leeds 4	0532 636212

SCOTLAND

Churchills (Prms) Ltd., 90-92 Commerce Street, Glasgow	041 429 3781
R. & M. Dorricott, Market Square, Inverberrie, Kincardineshire	056 16 208
J.B. Duff, 460 George Street, Aberdeen	0224 22994
Finnies Sports & Cycle Centre, 40 Newmarket Street, Ayr	0292 82368
A. Junner & Co. Ltd., 36-38 Batcher Street, Elgin, Morayshire	Elgin 2492
A. Junner & Co. Ltd., 14-16 Greig Street, Inverness	0463 36704
W. & R. MacDonald, 26 Morrison Street, Edinburgh 3	031 229 8473
McLennan (Cycle Shop), 32 Cromwell Street, Stornaway, Isle of Lewis	0851 2202
J.M. Richard, 44 George Street, Perth	0738 26860

WALES

Claude Crimes, 8-10 Station Road, Queensferry	024 451 2554
Hughes Cycles, 20 Bodfor Street, Rhyl	0745 2012
Reg Braddick & Sons Ltd., 59-61 The Broadway, Cardiff	0222 490137
Kennards Ltd., 195-201 Richmond Road, Cardiff	0222 22131

Additionally, any Halfords Branch would be pleased to assist you in arranging for your Raleigh Bicycle or Toy to be serviced.

IceniCAM On-Line Library

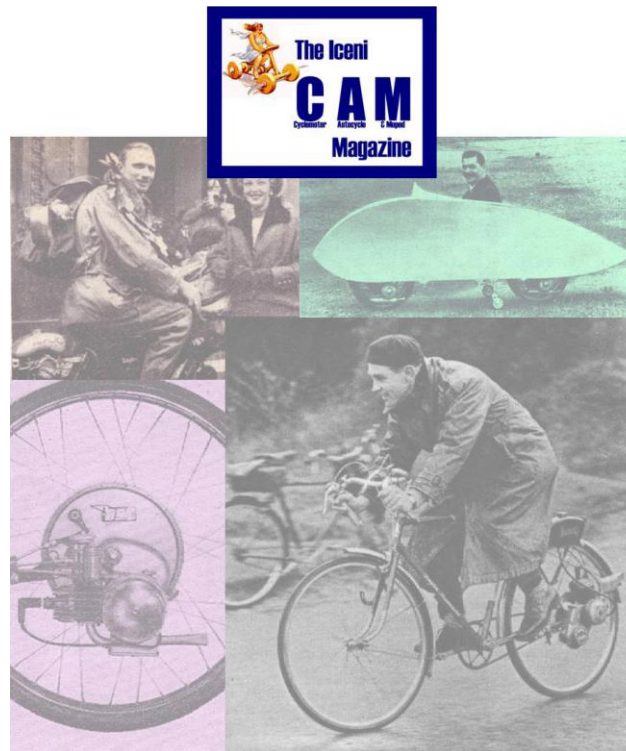

www.icenicam.org.uk