

CYCLE *Maintenance* HANDBOOK

Raleigh Industries Limited

including

Sturmey-Archer Hub Gears and Brakes
'Dynohub' Hub Lighting Equipment, etc.

Issued  *by*

RALEIGH INDUSTRIES LIMITED

Makers of Fine Bicycles

NOTTINGHAM

ENGLAND

FOREWORD

The instructions given in the following pages cover all points of adjustment and lubrication and will help you to maintain your bicycle in perfect condition. With its aid you will enjoy many miles of happy and trouble-free cycling.

Our Dealers are ably supported, not only by the Service Organisation of our Wholesale Depots and Distributing centres throughout the world, but by our factory at Nottingham, which has had nearly 70 years' valuable experience of building and maintaining quality bicycles.

Such Dealers, therefore, are in a position to give satisfaction in any matter on which you may desire further advice or assistance.

CONTENTS

	Page
Ball Bearing Chart - - - - -	39
Bottom Bracket - - - - -	16-17
Brakes—Cable-operated, Front and Rear Hub - - - - -	12
Calliper, Front and Rear - - - - -	10
Rod-operated, Front Hub - - - - -	8
Rod-operated, Rear Hub - - - - -	9
Roller Lever, Front - - - - -	6
Roller Lever, Rear - - - - -	7
Bicycle Identification Form - - - - -	39
Chain Drive and Cranks - - - - -	16
Cleaning - - - - -	35-37
'Dynohub' Lighting - - - - -	28-29
AG & SG Dynothree - - - - -	28-29
FG Dynofour - - - - -	28-29
GH6 Front 'Dynohub' - - - - -	28-29
Dry Battery Unit - - - - -	30-31
Filter Switch Unit - - - - -	32-33
Gearcase - - - - -	18
Handlebars - - - - -	5
Hints and Tips - - - - -	36
Hooded Levers - - - - -	11
Lock, Front Fork - - - - -	22
" Frame - - - - -	22
Lubrication - - - - -	20-21
National Engineering Award - - - - -	38
Oil (Back Cover) - - - - -	40
Pedals - - - - -	19
Prop Stand - - - - -	23
Riding Position - - - - -	4
Saddle - - - - -	4
Steering Head - - - - -	19
Sturmey-Archer Gears - - - - -	24-27
Bearing Adjustment - - - - -	26
Brake Linings - - - - -	26
Gear Adjustment - - - - -	24-25
Gear Ratio Tables - - - - -	34-35
Trigger 'Flick' Control - - - - -	27
Tyres, Care of - - - - -	36-37
Wheels, Front - - - - -	13
" Rear (28", Balloon, Carrier and Junior) - - - - -	14
" Rear (24", 26" and 27") - - - - -	14-15

To adjust the

Height of Saddle

Slacken nut "A", move saddle to required height, then tighten nut "A". At least $2\frac{1}{2}$ " of the seat pillar should remain in the frame. For the correct position of the saddle, see below. The lateral position of the saddle may be adjusted by slackening nuts "B" on each side and sliding saddle chassis forward or backward as desired. If saddle is still too far forward, remove saddle and reverse the clip so that nuts "B" are at position "C" at rear of seat pillar, then slide saddle to the desired position. Tighten nuts "B" equally.

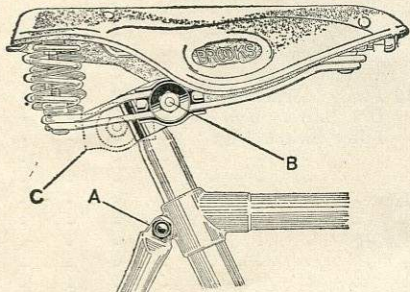

Riding Position

Correct saddle-height can be determined by the rider placing his heels on the pedals when at their lowest position, with the leg fully extended. This allows for a slight bend in the knee when pedalling with the ball of the foot on the pedal. The nose of the saddle should be about two inches behind a vertical line cutting through the centre of the bottom bracket; the nose of the saddle tilted slightly upwards.

With the handlebar grips approximately in line with the top of the saddle, the rider should feel his weight is so balanced that the hands rest lightly on the handlebars, thus preventing strain on the wrists and forearms.

A sound general rule is to adjust the position so as to disperse the weight of the rider's body evenly over the three points of contact, i.e. handlebars, saddle and pedals.

To adjust the

Height of Handlebar

CALLIPER BRAKE MODELS

Unscrew expander bolt "X" two complete turns and gently tap it down. Move handlebar to desired position and tighten expander bolt. At least $2\frac{1}{2}$ " of handlebar stem must remain in the fork steering tube.

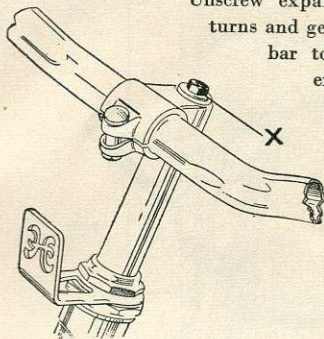

If bicycle is fitted with a head clip (not illustrated) slacken head clip nut, move handlebar to the desired position and tighten head clip nut.

ROD BRAKE MODELS

Slacken the nuts "A" and "E" on the brake rods, unscrew the expander bolt "X" two complete turns and gently tap down. Move the handlebar to desired position, tighten expander bolt "X". At least $2\frac{1}{2}$ " of handlebar stem must remain in fork steering tube. Adjust front and rear brakes as detailed on pages 6 and 7 or 8 and 9.

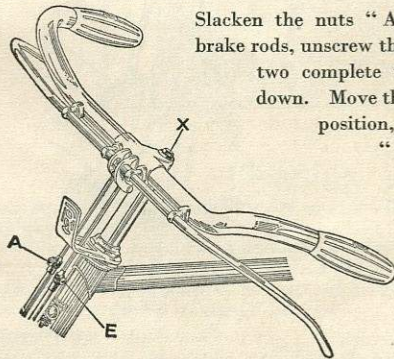

To adjust the

Rod-operated Front Brake

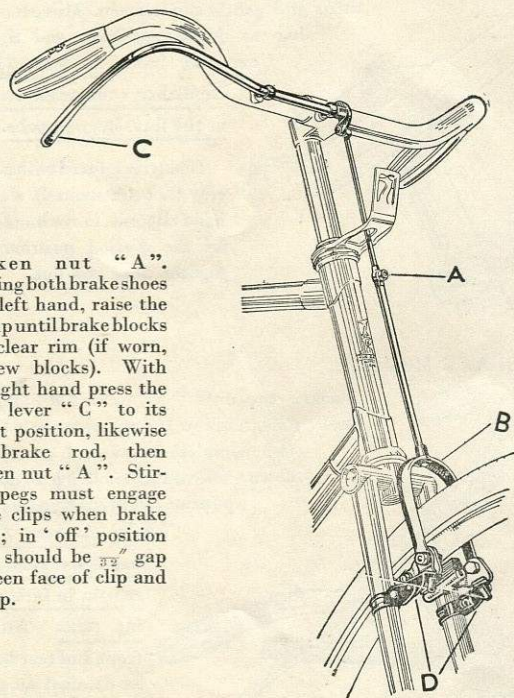

Slacken nut "A". Holding both brake shoes with left hand, raise the stirrup until brake blocks just clear rim (if worn, fit new blocks). With the right hand press the roller lever "C" to its lowest position, likewise the brake rod, then tighten nut "A". Stirrup pegs must engage brake clips when brake is on; in 'off' position there should be $\frac{3}{32}$ " gap between face of clip and stirrup.

To adjust the

Rod-operated Rear Brake

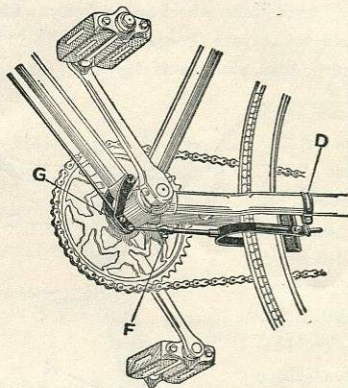

Slacken nuts "E" (page 5) and "F", move the brake stirrup until brake blocks just clear rim; retain this position (if worn, fit new blocks). Set the bottom bell crank "G" until it touches bottom bracket and tighten nut "F". Tension the brake rods at point "H" (page 9) by raising brake tube with left hand. With the right hand press the roller lever and rod to its lowest position, then tighten nut "E" (page 5). Stirrup pegs must engage brake clips when brake is on; in 'off' position there should be $\frac{3}{32}$ " gap between face of clip and stirrup.

To adjust the

Rod-operated Front Hub Brake

(a) Tighten thumb nut "F" until brake just binds and then slacken thumb nut "F" until front wheel spins freely. Check clip "D" for tightness and make sure Torque Arm Clip "J" completely engages the Torque Arm, also check clip "J" for tightness.

(b) If the handlebar height is altered slacken nut "A" and thumb nut "F". Hold stirrup arch "K" in a horizontally balanced position by the left hand, and with the right hand press roller lever "B" to the lowest position, likewise rod "C", then tighten nut "A" and proceed as paragraph (a).

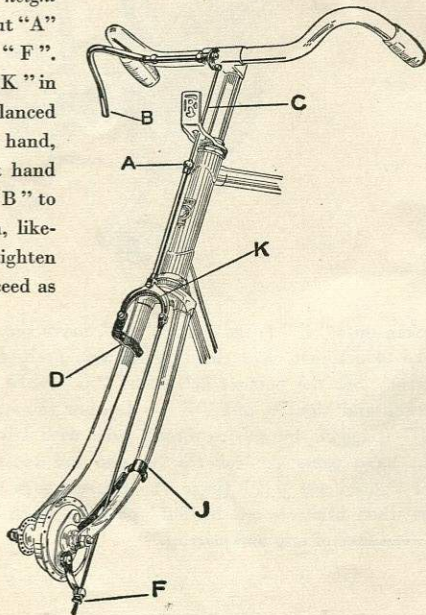

8

To adjust the

Rod-operated Rear Hub Brake

(a) Tighten thumb nut "F" (Fig. 2) until brake just binds and slacken thumb nut "F" until rear wheel spins freely. Check Torque Arm Clip "J" for tightness (Fig. 2).

(b) If the handlebar height is altered slacken nut "E" (Fig. 1), set bottom bell crank "C" (Fig. 2) until it touches the bottom bracket. Tighten thumb nut "F" (Fig. 2) until brake just binds, then slacken thumb nut "F" until wheel spins freely. With the right hand press roller lever "B" (Fig. 1) to its lowest position, likewise rod "C" (Fig. 1), with the left hand lightly tension the brake rods by slightly raising the bell crank at "H" (Fig. 1) and tighten nut "E" (Fig. 1). Re-check rear wheel for free running and check Torque Arm Clip "J" (Fig. 2) for tightness.

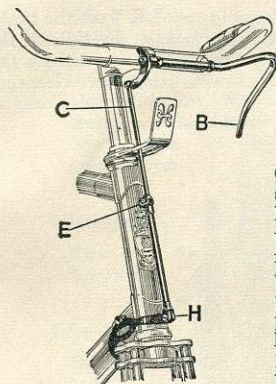

FIG. 1.

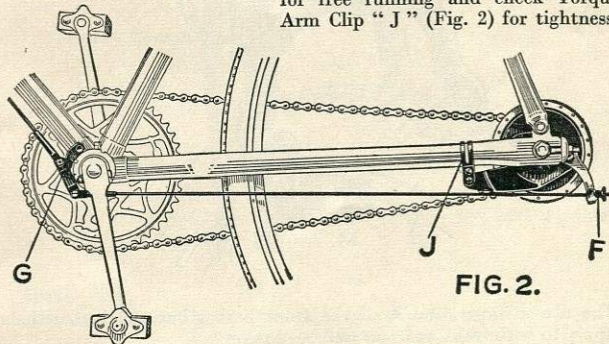

FIG. 2.

9

To adjust the

Calliper Front and Rear Brakes

Slacken the finger-nut "J". With the adjuster "K" set the brake blocks to just clear rim (if worn, fit new blocks). Re-tighten the finger-nut "J". If one brake block contacts the rim, lightly tap down the opposite side coil "L" of the brake spring, until clearance is equidistant. Set the brake blocks "M" to contact the rims so that they do not touch the tyre walls when brake is applied.

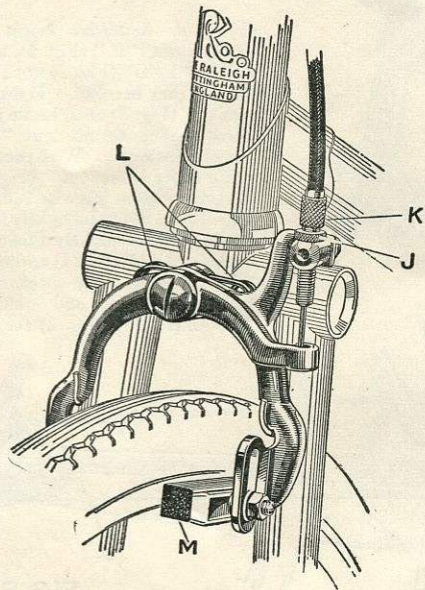

The above illustration is of the front brake, but the instructions apply to both front and rear Calliper brakes.

Hooded Levers

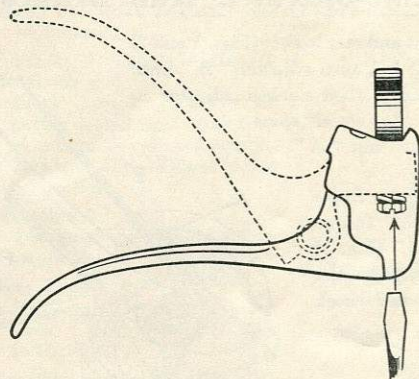

Hooded levers are secured to the handlebar by a bolt which is concealed within the hood of the lever. To adjust the position of the lever the cable must be released from the slot in the hood and moved downwards. (To facilitate this, the cable stop should be detached from the calliper brake stirrup.) The bolt head will then be revealed. In re-tightening, care must be taken to see that the bolt is thoroughly tightened with a good screw-driver, as this bolt secures the lever to the handlebar.

The lever must never be forced into a new position ; the bolt must be slackened and re-tightened when the lever has been re-positioned. If force is applied, damage to the chromium plating of the handlebar and looseness of the lever may result.

To adjust the

Cable-operated Hub Brakes

For both front and rear brakes (Figs. 1 and 2) slacken nut "A", turn adjuster "B" until brake just binds, then slacken adjuster "B" until the wheel spins freely. Tighten nut "A".

On the Front Brake make sure the Torque Arm Clip "C" (Fig. 1) completely engages the Torque Arm and check for tightness.

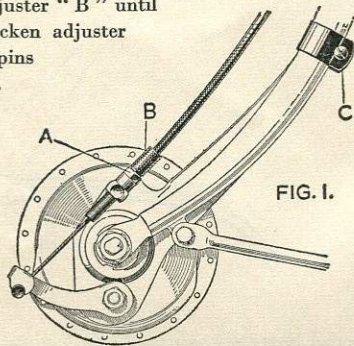

On the Rear Brake check clip "D" (Fig. 2) for tightness.

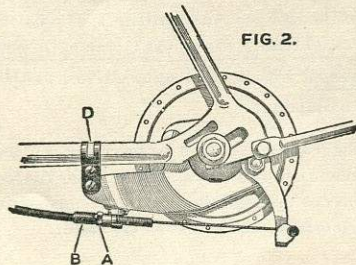

To adjust the

Front Wheel

28" WHEEL BALLOON, CARRIER AND 16"/18" JUNIOR MODELS

Slacken the axle nut "A" only on the adjusting cone side (left-hand), gently tighten cone "B" until 'play' is removed (do not over-tighten), then slacken the cone half a turn. Tighten the axle nut "A" at the same time centring wheel in forks. If adjusted correctly, weight of tyre valve should cause wheel to rotate. If front wheel is removed from the forks, when reinserting see that adjuster cone is on the left-hand side (opposite side to gear wheel).

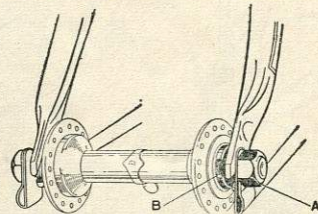

26" and 27" WHEEL MODELS (excluding Balloon and Carrier)

Invert bicycle, slacken but do not remove axle nuts and washers "A"—remove wheel. Slacken locknut "C" on side where axle is grooved, and gently tighten cone "B" until all 'play' is removed—then slacken cone half a turn. Move washer "D" until it abuts the cone and tighten locknut "C". If adjusted correctly, weight of tyre valve should cause wheel to rotate. Replace wheel in forks with grooved end of axle on left-hand side (opposite side to gear wheel). Centre wheel in forks and tighten axle nuts "A".

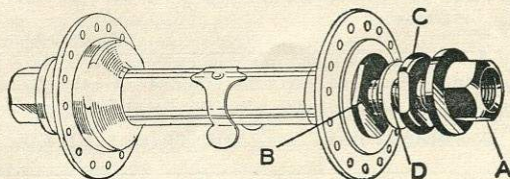

To adjust the

Rear Wheel

28" WHEEL, BALLOON, CARRIER AND 16" JUNIOR MODELS
Slacken axle nut "A" only on side opposite to free-wheel. Gently tighten cone "B" until 'play' is removed (do not over-tighten), then slacken cone half a turn. Tighten axle nut "A" at the same time centring wheel in chainstays and backstays. If adjusted correctly, weight of tyre valve should cause wheel to rotate. On Junior models check chain tension as detailed on page 16.

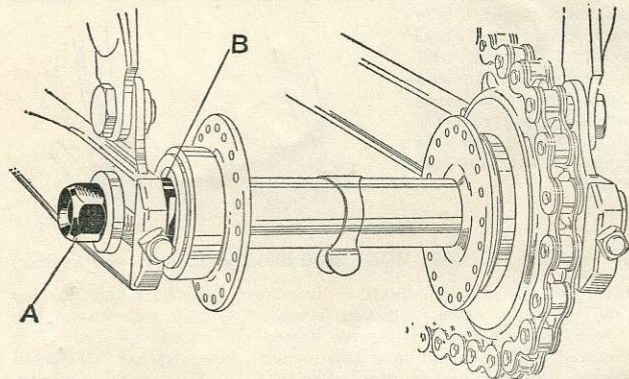

24", 26" and 27" WHEEL MODELS (except Balloon and Carrier)
Invert bicycle, slacken, but do not remove, axle nuts and washers "A"—remove wheel. Slacken locknut "C" (not visible on Fig. 2) on side where axle is grooved, and gently tighten cone "B" until all 'play' is removed.

Continued next page

Whenever replacement parts are required, fit only Genuine
Raleigh Industries Precision-tested SPARE PARTS.
Distributed by RALEIGH INDUSTRIES LIMITED.

Slacken the cone half a turn and tighten locknut "C". If adjusted correctly, weight of tyre valve should cause wheel to rotate. Centre wheel in chainstays and backstays, tension chain correctly (page 16) and tighten axle nuts "A".

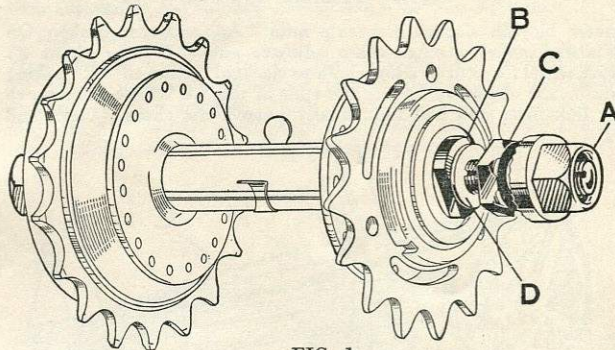

FIG. 1

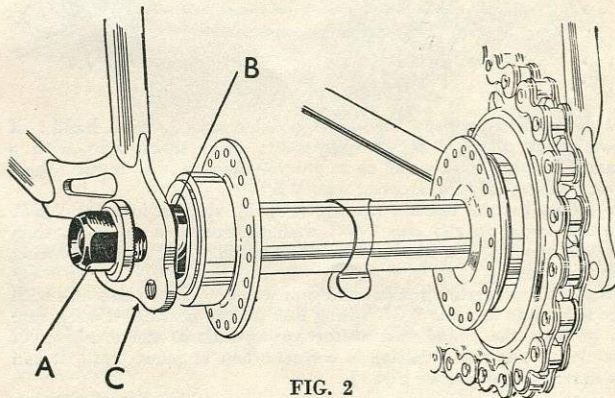

FIG. 2

To adjust the

Crank, Bottom Bracket and Chain Drive

Invert bicycle, slacken rear axle nuts "A" and rear brake. On Roadster models slacken chain adjuster nuts "B" for about $\frac{1}{8}$ ". Move wheel forward to allow chain to slacken. Take off "C" spring link on the chain, by forcing the ends of the "C" forward, remove the link plate and half link, finally remove the chain. Clean and

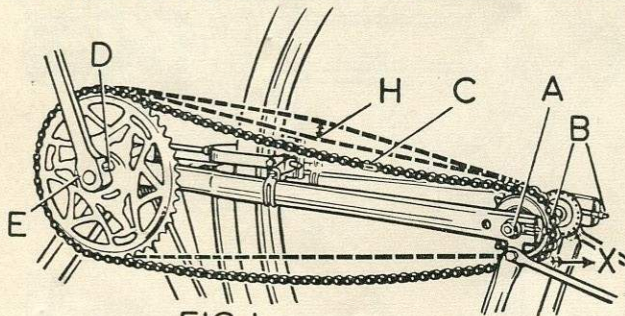

FIG. 1

oil as detailed on page 36. Hold pedal cranks in each hand; if loose, slack cotters "D" are apparent; drive them tight with a hammer, using hard-wood as a punch—damage will result otherwise. Re-tighten crank cotter nuts "E".

To adjust bottom bracket bearing (Fig. 2), slacken locking "F". Firmly screw up the cup "G" without excessive pressure, then slacken about $\frac{1}{8}$ of a turn and tighten locking "F". Test bearing for free running.

Loop chain over rear sprocket and gear wheel. Fit the half link with the link plate and the "C" spring link on the outside—taking care to position the closed end of the spring link in the direction of rotation. The chain tension is correct when at point "H" it can be moved about $\frac{1}{2}$ " (See Fig. 1).

Continued next page

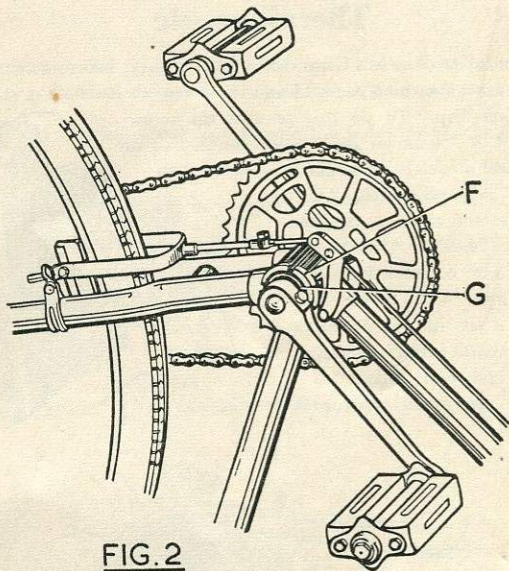

FIG. 2

28" WHEEL, BALLOON AND CARRIER MODELS

Tighten adjuster nuts "B" (Fig. 1) until tension is correct, and wheel is central in chainstays and backstays. Tighten axle nuts "A". Re-adjust rear brake (for details see pages 7 or 9).

26" and 27" WHEEL AND JUNIOR MODELS (excluding Balloon)

Move wheel in direction of "X" (Fig. 1) by hand until the chain tension is correct. Tighten axle nut "A" on chainside only, set wheel central in chainstays and backstays, then tighten remaining axle nut "A". Re-adjust the rear brake (for details see pages 7 and 9 for rod brakes and on pages 10 and 12 for cable brakes).

The Gearcase

If cycle is fitted with a Gearcase, it is necessary, before attempting adjustments shown on pages 14 and 16, to remove Gearcase End Cap. To do this remove the screw or screws "A" (one on 28" wheel models, two on 26" wheel models) Fig. 1, also remove the two slides "B" and end cap "C", then proceed either as detailed on pages 14 or 16. After adjustments are completed replace end cap "C", taking care to see that all lips fit inside the gearcase. Replace screws "A" and refit slides "B". Rotate rear wheel to check

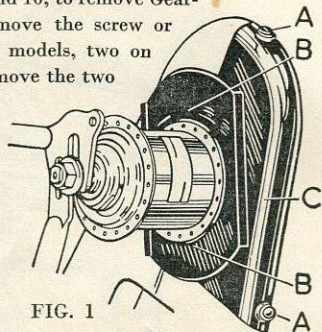

FIG. 1

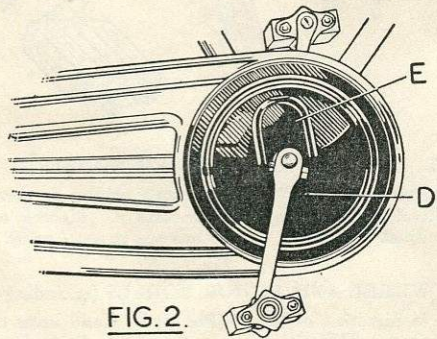
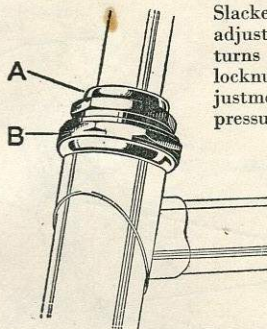

FIG. 2.

free running. If disc "D" (Fig. 2) is removed be sure to replace slide "E" in the uppermost position.

To adjust the

Steering Head



Slacken the locknut "A", gently turn the adjustment nut "B" clockwise until head turns freely without 'play', and tighten locknut "A". When tightening the adjustment nut "B" do not use excessive pressure as damage to the ballraces will result.

If bicycle is fitted with a head clip (not illustrated) it is necessary to slacken the Head Clip Nut before proceeding as previous paragraph. This nut should be tightened after the steering head adjustment has been completed.

To adjust the

Pedals

Check pedals for tightness in cranks at "A". Remove the dust-cap "C", slacken spindle nut "D" and with a penknife disengage the locking washer "E" from cone "F", tighten cone until all 'play' is removed; do not over-tighten. Slacken the cone half a turn, refit locking washer "E" and tighten spindle nut "D". Pedal should spin freely after adjustment. Refit the dust-cap "C".

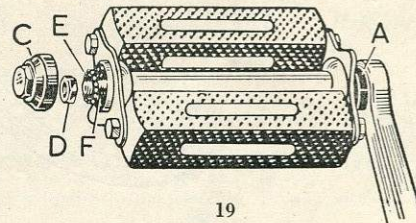

Where to Lubricate

To ensure sweet running and long life of wearing parts lubricate once a fortnight at all points shown on diagram.

On SPORTS MODELS
lubricate the brake cables
at both ends.

If a gearcase is fitted, insert not more than a teaspoonful of Raleigh Industries 'All-purpose' Oil once a fortnight, through the lubricator, slowly revolving cranks.

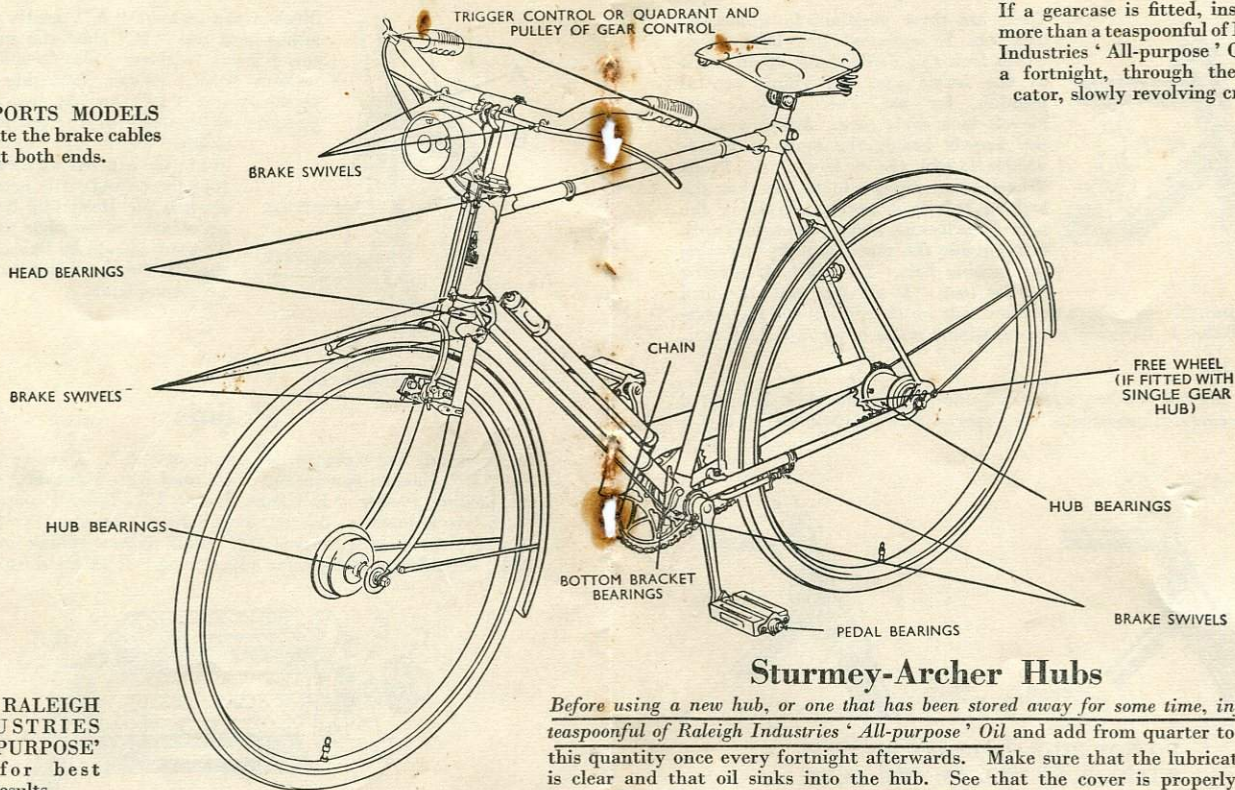

Use RALEIGH
INDUSTRIES
'ALL-PURPOSE'
OIL for best
results.

Sturmev-Archer Hubs

Before using a new hub, or one that has been stored away for some time, inject one teaspoonful of Raleigh Industries 'All-purpose' Oil and add from quarter to half of this quantity once every fortnight afterwards. Make sure that the lubricator hole is clear and that oil sinks into the hub. See that the cover is properly closed afterwards. Oil trigger control inner wire occasionally. Do not use thick oil or grease.

The Patent Front Fork Lock

THE LOCK

There are three positions in which the lock can be operated (see left). Two which lock the Front Fork at an angle to the frame and the third, central position, for use when parking the bicycle in a cycle rack. When parking the bicycle beside the kerb, it is advisable to lock the cycle with the Front Wheel at an angle and to see that the locking bolt is correctly housed in the hole of the locking plate. Never lock with bolt outside the plate, thereby exposing the locking bolt. Do not lubricate the key or lock. If oil gets into the lock

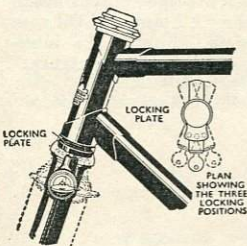

mechanism, it may collect dust and grit which will impede its operation. All that is necessary is an occasional smear of oil on locking bolt.

THE KEY

Make a note of the key letter and number, as this must be quoted if replacement is required. Take special care to avoid loss of key.

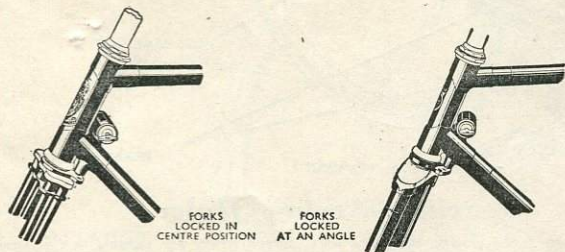

**DO NOT RIDE OR LEAVE BICYCLE
WITH KEY STILL IN THE LOCK**

Prop Stand

This unit does not require lubrication, and the only maintenance necessary is to keep the return spring free from mud and grit.

If the stand is being fitted to a bicycle the following points should be noted :—

On 28" wheel machines the clamping plate may be fitted either way.

On all other types the clamping block is wedge-shaped and must be fitted with the narrow edge facing forwards. After fitting, check that the prop stand leg clears the crank and rear wheel before the final tightening of the fixing bolts.

DO NOT OVER-TIGHTEN.

DO NOT SIT ON MACHINE WITH THE STAND DOWN.

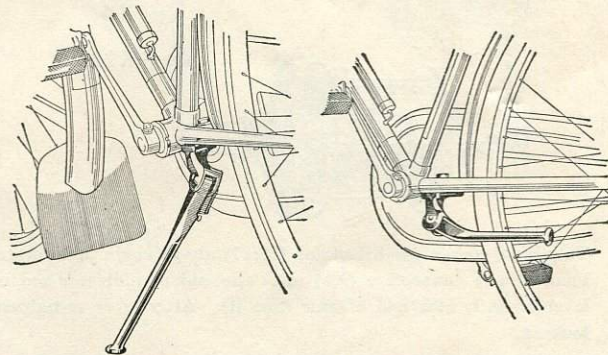

Sturmey-Archer Gear Hubs, Brake Hubs and 'Dynohub' Hub Lighting Equipment

Gear adjustment for Sturmey-Archer SG, SW, SB, AM, FW, FM, and FG hubs. Left hand indication.

(Note that SW and SG hubs can be either left hand or right hand indication.)

Place control lever in :-

Middle gear position (No. 2), i.e.

normal gear for SW, SB, SG and AM hubs.

Low gear ("L" in trigger control window), i.e. next to bottom gear for FW, FM and FG hubs.

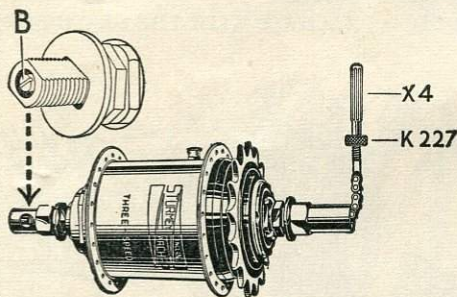

To adjust, loosen small locknut (K227) above chain and rotate knurled wire connection (X4) until the end of indicator rod is level or flush with end of axle (See B). Afterwards re-tighten locknut.

If insufficient adjustment is obtained by this means, move the quadrant (or fulcrum clip in the case of a handlebar control) along

the top tube in the required direction, and make the final adjustment on the chain connection as described above.

Should gears slip, check and re-adjust immediately.

Gear adjustment for Sturmey-Archer AB, TCW and AG hubs.

Right hand indication.

Place control lever in middle gear position, i.e. Normal Gear. To adjust, loosen small locknut (K227) above chain and rotate knurled wire connection (X4) until the outer shoulder on indicator attached to small chain at sprocket side is level or flush with end of axle (See B). Afterwards re-tighten locknut.

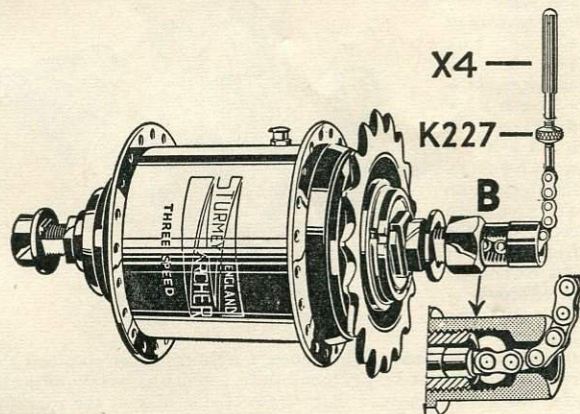

If insufficient adjustment is obtained by this means, move the quadrant (or fulcrum clip in the case of a handlebar control) along the top tube in the required direction, and make the final adjustment on the chain connection as described above.

Should gears slip, check and re-adjust immediately.

Lubrication.

See pages 20-21.

Bearing adjustment for Sturmey-Archer hubs.

The right-hand cone is fixed at Works and should not be touched. Bearings are adjusted by loosening the locknut on the left-hand side and adjusting the cone suitably, then re-tightening the locknut. A properly adjusted wheel should have a trace of side play at the rim. This adjustment automatically sets all the bearings in the hub.

Bearing adjustment for BF, BR, AB, SB and TCW Hubs.

The adjustment is carried out in exactly the same way as described above, but the cone arrangement is slightly different. A notched washer is fitted over the adjustable cone on the brake side. Adjustment is effected by loosening the locknut and turning this washer. When correct adjustment is obtained the cone locknut must be tightened fully. When correctly adjusted the wheel should have a slight trace of side play at the rim.

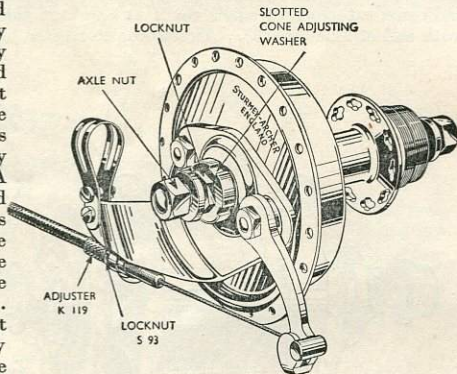

Brake lining renewals. BF, BR, SB and AB.

If efficiency is impaired and cannot be corrected by adjustment, brake linings may be worn and need renewal. Your Dealer should be consulted, he will arrange to re-line the brake shoes.

Brake. TCW.

Lubrication of the gear automatically provides for the brake mechanism. No other attention is necessary. If the brake requires attention the Dealer should be consulted.

Sturmey-Archer Patent Handlebar Trigger 'Flick' Control

To remove control wire.

It is not necessary to remove control from handlebar if the lever can be pulled back far enough to allow cable nipple to pass between pawl and ratchet plate. Procedure is :- Detach (1) inner wire from indicator chain at hub; (2) outer casing from fulcrum clip. Pull cable ferrule "F" upward until screw thread engages that of control casing at "B", then unscrew ferrule. Pull lever right back beyond bottom gear position to stop "A", push inner wire through to detach nipple from ratchet plate, then pull wire out between pawl and ratchet at "C" and finally through threaded hole "B".

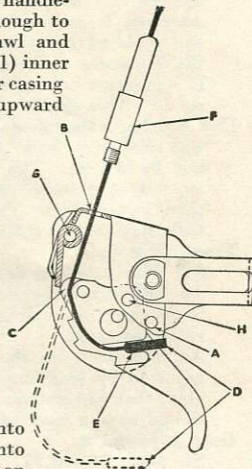

To fit control wire.

Pull lever right back beyond bottom gear position to stop "A" and insert wire through threaded hole "B" and between pawl and ratchet plate at "C". Wire nipple "D" is then fitted into notch "E" and cable ferrule "F" screwed into "B" until it rotates freely. Keeping tension on wire, push lever forward into top gear position. Control is then ready for re-connection.

Pawl and Pawl Spring.

These two parts are designed so that they cannot drop out through breakage of control wire or during removal or replacement. They should not normally need renewal, therefore they are not readily detachable. If a new part is required both rivets "G" and "H" must be removed, and the complete trigger mechanism withdrawn. New rivets must be used in re-assembly.

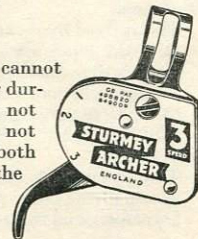

Sturmey-Archer Front 'Dynohub', Dynothree and Dynofour

IMPORTANT WARNING.

Should it ever be necessary to separate the armature from the magnet a 'keeper ring' for magnet must be used. The armature is removed by pushing it out with the keeper ring and replaced by reversing the process; in other words, either the armature or keeper ring must always be in the magnet. If separation occurs, even for an instant, loss of magnetism will result. This applies to all 'Dynohub' magnets.

Hub Bearing Adjustments. Dynothree and Dynofour.

The cone away from the Dynamo is fixed at Works and should not be moved. The bearings are adjusted by loosening the locknut at dynamo end and rotating the four-notched washer, then re-tightening the locknut. A correctly adjusted wheel should have only a trace of side play at the rim.

Front 'Dynohub'.

The dynamo-side cone is locked to the axle and must not be moved. The armature is locked to this cone by means of a locknut. If it is necessary to remove armature note number of washers when replacing same.

Adjustment is on the side away from the dynamo. Bearings are adjusted by loosening the locknut and adjusting the cone suitably, then re-tightening the locknut. A properly adjusted wheel should have a trace of side play at the rim.

Gear Adjustment.

See pages 24 and 25.

Lubrication.

See pages 20-21.

Headlamp.

This is fixed by means of a single clamping bolt. Do not attempt to alter the lamp angle without first loosening clamping bolt. The front is detachable by undoing the screw at the bottom for access to the bulb and connections. The switch has three positions: 'On' is towards the right hand when seated on the bicycle and 'Off' to the left; the central position is only used on DBU sets.

Rear Lamp.

This is fixed by clip to rear stay. The dome unscrews to give access to the bulb. Earthing is only necessary for Dynothree and Dynofour, and this is covered by wiring instructions given opposite.

Wiring.

Wiring connections are inside lamp; wires enter lamp through a hole in the fixing bracket. To reach connections lamp front must be removed.

1. For front 'Dynohub' (GH6) :— Headlamp end.

Black wire to upper R.H. switch connection. Red wire to centre switch connection. Two bare wires to lower centre connection.

'Dynohub'.

Two hook connections to hub terminals.

Rear Lamp.

Black wire (large tag) to clip screw. Red wire (small tag) to terminal.

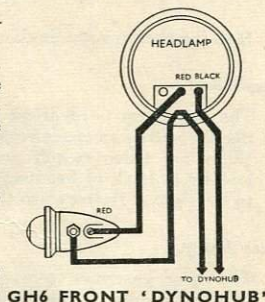

2. For Dynothree (SG, AG) and Dynofour (FG) hubs :—

Headlamp end.

Black wire to upper R.H. switch connection. Red wire to centre switch connection.

'Dynohub'.

Two hook connections to hub terminals.

Rear Lamp.

Black wire (large tag) to clip screw. Red wire (small tag) to terminal.

Earth wire.

Rear lamp clip screw to seat bolt.

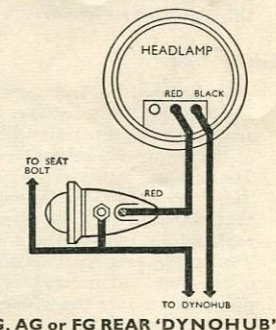

SG, AG or FG REAR 'DYNOHUB'

Illustrations show switch plate as seen in headlamp with front removed.

Bulbs.

GH6. Head—6v. .25 amp.; Rear—6v. .04 amp.
SG, AG and FG. Head—6v. .25 amp.; Rear—6v. .04 amp.
Correct bulbs must be used.

Dry Battery Unit

(Type D.B.U.)

Hub instructions are as shown on pages 24 and 28.

Headlamp.

The headlamp is identical with the one described on page 28, but the wiring arrangements are different and are shown opposite. There are three switch positions. When seated on the cycle looking at back of headlamp, the lever positions are 'Dynamo' to the right, 'Battery' to the left and 'Off' when central.

Rear Lamp.

The dome unscrews to give access to bulb. It is not necessary to remove enamel from frame for earthing as this is arranged through wiring system.

Battery Unit.

This is fitted to seat tube of cycle frame and contains three $1\frac{1}{2}$ volt Dry Cells. These are NOT re-chargeable and must be replaced with new cells when exhausted. Earthing is by means of the spring clip at the base.

The wiring is attached to the terminals at the top of the container. There are only two terminals and these are of different sizes so that wires cannot be wrongly connected. The batteries are replaced by removal of a spring at the base of the container. The spring ring and its groove *must* be kept clean. A smear of vaseline will prevent corrosion. The rubber cap should be pulled down over the wiring.

Batteries.

Standard equipment is Drydex T.20 or G.E.C. BA. 6103, but any equivalent is suitable. These are fitted one above another as in an ordinary torch. They should be removed as soon as exhausted to avoid corrosion. Their removal does not affect Dynamo lighting in any way.

Wiring for Front and Rear D.B.U.

Headlamp end.

Black wire to upper R.H. switch connection.

Bare wire to lower centre connection.

Red wire to upper centre switch connection.

Green wire to upper L.H. switch connection.

'Dynohub'.

Two hook connections to hub terminals.

Rear Lamp.

Black wire (large tag) to clip screw.

Red wire (small tag) to recessed screw.

Battery Container.

Red wire (large tag) to centre terminal.

Black wire (small tag) to side terminal.

Earth Wire.

Rear lamp clip to seat bolt.

On rear 'dynohub' the two main cables are held together by sleeving at various points.

Bulbs.

Head—6v. .25 amp. No. GL448.

Rear—6v. .04 amp. No. GL228.

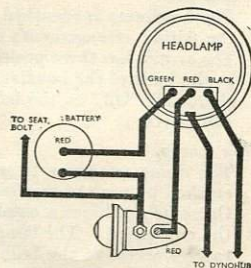

D.B.U. FRONT OR REAR
'DYNOHUB'

Illustration shows switch plate as seen in headlamp with front removed.

Filter Switch Unit

(Type F.S.U.)

Hub instructions are as given on pages 25 and 28.

Headlamp.

The headlamp is identical with the one described on page 28, but the wiring arrangements are different and are shown opposite. The switch has three positions. When seated on the cycle looking at the back of the headlamp, the lever positions are 'On' to the right and 'Off' to the left; the central position is only used on DBU sets.

Rear Lamp.

The dome unscrews to give access to the bulb. Rear lamp is earthed by wire to seat lug. On some machines a combined rear lamp and reflector is fitted to the mudguard. The lamp dome pulls out of the rubber moulding to give access to the bulb. The rear lamp is earthed to the mudguard by the fixing screw.

Filter Switch and Battery Unit.

This is fitted to seat tube of cycle frame and contains three 1½ volt Dry Cells. Type supplied by us is Ray-o-Vac, but any equivalent is suitable. They are not re-chargeable, and must be removed as soon as exhausted to avoid corrosion. Note that, if necessary, the set can be run without batteries, when it will function as a normal dynamo lighting set.

Wiring.

Wires enter headlamp through hole in fixing bracket. For access to connections lamp front must be removed.

Two wiring harnesses are now used; one to suit the backstay fitting rear lamp, the other to suit the combined reflector and rear lamp mounted on the mudguard. The wiring diagrams show both types.

Headlamp.

Red connection to upper centre switch connection.
Green connection to upper R.H. switch connection.

Rear Lamp.

Large black tag to rear lamp clip screw. Red tag to rear lamp terminal.

Combined Rear Lamp and Reflector.

A semi-stiff positive wire is fitted inside the mudguard and connects the rear lamp to the terminal socket situated near the backstay bridge. The wire from F.S.U. without identification tag is fitted into this socket.

F.S.U.

The two wires without identification tags plug into the sockets marked "D". Red sleeved wire fitted to socket marked +. Black sleeved wire fitted to socket marked —.

'Dynohub'.

Two hook connections to hub terminals.

Earth Wire.

Rear lamp clip screw to seat bolt.

Earth Wire for combined Rear Lamp and Reflector.

From socket marked — (negative) in filter switch unit to seat bolt.

Bulbs.

Head—6v. .2 amp. No. GL474.
Rear—6v. .04 amp. No. GL228.
Correct bulbs must be used.

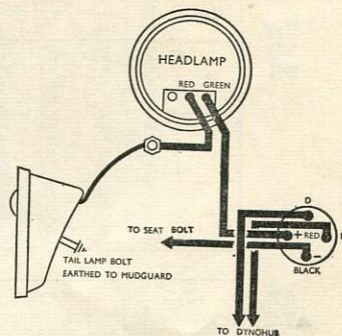

(Illustrations show switch plate as seen in headlamp with front removed.)

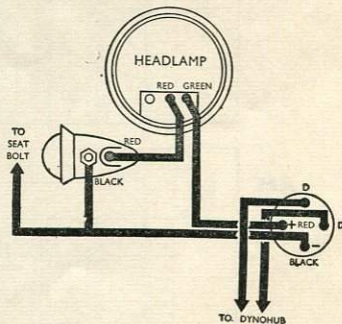

Gear Ratio Tables

SW
SB
SG

Chain Wheel	Sprocket	26" Wheels			28" Wheels		
		1	2	3	1	2	3
		Low		High	Low		High
44	16	51.6	71.5	99.0	55.6	77.0	106.6
	17	48.6	67.3	93.2	52.4	72.5	100.3
	18	45.9	63.6	88.0	49.4	68.4	94.7
	19	43.5	60.2	83.3	46.8	64.8	89.7
	20	41.3	57.2	79.2	44.5	61.6	85.3
	22	37.6	52.0	72.0	40.5	56.0	77.5
46	16	54.0	74.7	103.4	58.2	80.5	111.4
	17	50.8	70.3	97.3	54.8	75.8	104.9
	18	48.0	66.4	91.9	51.6	71.5	99.0
	19	45.4	62.9	87.1	49.0	67.8	93.8
	20	43.2	59.8	82.8	46.5	64.4	89.1
	22	39.3	54.4	75.3	42.3	58.4	81.1
48	16	56.3	78.0	108.0	60.7	84.0	116.3
	17	53.1	73.5	101.7	57.1	79.1	109.5
	18	50.1	69.3	95.9	54.0	74.7	103.4
	19	47.5	65.7	90.9	51.1	70.7	97.9
	20	45.1	62.4	86.4	48.5	67.2	93.0
	22	41.0	56.7	78.5	44.1	61.1	84.6

AB,
ABC,
AG
and
TCW

Drive Wheel	No. of Teeth on Hub Sprocket	26" WHEELS			28" WHEELS		
		Low	Mid.	High	Low	Mid.	High
		44	16	53.6	71.5	95.3	57.8
17	50.5		67.3	89.8	54.4	72.5	96.7
18	47.7		63.6	84.8	51.3	68.4	91.2
19	45.2		60.2	80.3	48.5	64.8	86.4
20	42.9		57.2	76.7	45.2	61.6	82.1
16	56.0		74.7	99.6	60.4	80.5	107.3
46	17	52.7	70.3	93.7	56.9	75.8	101.1
	18	49.8	66.4	88.5	53.6	71.5	95.3
	19	47.2	63.0	83.9	50.9	67.8	90.4
	20	44.9	59.8	79.7	48.3	64.4	85.9
	16	58.5	78.0	104.0	63.0	84.0	112.0
	17	55.1	73.4	98.0	59.3	79.1	105.3
48	18	52.0	69.3	92.4	56.0	74.7	99.6
	19	49.3	65.7	87.6	53.0	70.7	94.3
	20	46.8	62.4	83.2	50.4	67.2	89.6

AM

Drive Chain Wheel	No. of Teeth on Hub Sprocket	26" WHEELS			27" WHEELS		
		Low	Nor.	Top	Low	Nor.	Top
44	14	70.7	81.7	94.2	73.6	84.8	97.9
	15	66.2	76.3	87.9	68.7	79.2	91.3
	16	62.1	71.5	82.6	64.3	74.2	86.6
	17	58.3	67.3	77.7	60.7	69.9	80.8
	18	55.2	63.6	73.5	57.2	66.0	76.2
	14	74.0	85.4	98.6	77.0	88.7	102.5
46	15	69.1	79.7	92.0	71.8	82.6	95.6
	16	64.8	74.7	86.2	67.3	77.6	89.5
	17	61.2	70.3	81.3	63.3	73.0	84.2
	18	57.6	66.4	76.8	59.8	69.0	79.6
	14	72.4	84.1	100.0	80.3	92.5	107.0
	15	72.1	83.2	96.0	75.0	86.4	100.0
48	16	67.7	78.0	90.0	70.2	81.0	93.5
	17	63.7	73.5	85.0	66.1	76.2	88.0
	18	60.0	69.3	80.2	62.5	72.0	83.2

Gear Ratio Tables

FW
and
FG

Chain Wheel	Sprocket	26" WHEELS				28" WHEELS			
		1	2	3	4	1	2	3	4
		Low		High		Low		High	
44	16	47.7	56.5	71.5	90.5	51.3	60.8	77.0	97.5
	17	44.9	53.2	67.3	85.2	48.3	57.3	72.5	91.0
	18	42.4	50.2	63.6	80.5	45.6	54.0	68.4	86.6
	19	40.1	47.6	60.2	76.2	43.2	51.2	64.8	82.0
	20	38.1	45.2	57.2	72.4	41.1	48.6	61.6	78.0
	16	49.8	59.0	74.7	94.5	53.7	63.6	80.5	101.9
46	17	46.9	55.5	70.3	89.0	50.5	59.9	75.8	95.9
	18	44.3	52.5	66.4	84.0	47.7	56.5	71.5	90.5
	19	41.9	49.7	62.9	79.6	45.2	53.6	67.8	85.8
	20	39.7	47.2	59.8	75.7	42.9	50.9	64.4	81.5
	16	52.0	61.6	76.0	96.0	56.0	66.4	84.0	106.3
	17	49.0	58.0	73.5	93.0	52.7	62.5	79.1	100.2
48	18	46.2	54.7	69.3	87.7	49.8	59.0	74.7	94.6
	19	43.8	51.9	65.7	83.2	47.1	55.8	70.7	89.5
	20	41.6	49.3	62.4	79.0	44.8	53.1	67.2	85.0

FM

Chain Wheel	Sprocket	26" WHEELS				27" WHEELS			
		1	2	3	4	1	2	3	4
		Low		High		Low		High	
44	14	54.5	70.1	81.7	91.9	56.5	72.6	84.8	95.5
	15	50.9	65.4	76.3	85.8	52.8	67.8	79.2	89.1
	16	47.7	61.3	71.5	80.4	49.5	63.6	74.2	83.5
	17	45.2	57.7	67.3	75.7	46.6	59.9	69.9	78.6
	18	42.4	54.5	63.6	71.5	44.0	56.5	66.0	74.2
	20	38.1	51.6	60.2	68.2	41.7	51.6	62.5	70.3
46	14	58.1	73.2	85.4	96.1	59.1	76.0	88.7	99.7
	15	53.1	68.4	79.7	89.7	55.2	70.9	82.8	93.1
	16	49.8	64.1	74.7	84.0	51.7	66.5	77.6	87.3
	17	46.9	60.3	70.3	79.1	48.7	62.4	73.0	81.9
	18	44.3	56.9	66.4	74.7	46.0	59.1	69.0	77.6
	19	41.6	53.9	62.9	70.8	43.6	56.8	65.4	73.9
48	20	39.9	51.3	59.8	67.3	41.4	53.2	62.1	69.8
	14	59.7	76.4	89.1	100.2	61.7	79.3	92.5	104.1
	15	55.5	71.3	83.5	93.6	57.6	74.0	86.4	97.2
	16	52.0	66.9	78.0	87.7	54.0	69.4	81.0	91.6
	17	49.0	63.0	73.5	82.7	50.8	65.3	76.2	85.0
	18	46.3	59.4	69.3	78.0	48.0	61.7	72.0	81.0
48	19	43.8	56.3	65.7	73.9	45.5	58.4	68.2	76.9
	20	41.6	53.5	62.4	70.2	43.2	55.5	64.8	72.9

Cleaning

Regular weekly cleaning will maintain the finish of chromium plated and enamel parts indefinitely.

Cleaning of the machine is simple and straightforward, but if it is not done at this regular interval deterioration will occur and the appearance and value of the bicycle will suffer.

The following procedure should be used :—

CHROMIUM. Dip a piece of rag in a solution of soft soap and hot water, wipe over, then polish by rubbing lightly with a clean rag and

just a trace of Raleigh Industries Oil. Chromium plating requires no other attention. Heavy rubbing should be avoided. Do not use any kind of metal polish on chromium plated parts.

TO CLEAN ENAMEL. Remove all dirt with a wet rag, taking good care not to scratch the enamel, then polish with a clean dry cloth and rub over lightly with a clean rag and a trace of Raleigh Industries Oil. Soda must never be used to clean any part.

If a silicone type of cleaner is considered, it should be used only on black enamel.

STAINLESS STEEL RIMS AND SPOKES. Wash with soapy water ; clean off with clean water, then rub over with a clean dry duster.

Hints and Tips

FREEWHEEL. Dirt accumulates in the freewheel, so clean it out occasionally by injecting paraffin; afterwards lubricate with Raleigh Industries 'All-purpose' Oil. Heavy body oil thinned down with paraffin will clog the freewheel mechanism. It is not necessary to remove the freewheel from the hub for cleaning purposes.

CHAIN. Oil the chain once a fortnight, using Raleigh Industries 'All-purpose' Oil, applying the oil on the inside run of the chain. If the bicycle is fitted with a gearcase, occasionally insert not more than a teaspoonful of Raleigh Industries 'All-purpose' Oil through the lubricator, slowly revolving the cranks so that the whole of the chain is evenly lubricated.

KIT BAGS. If the saddle is in a low position the kit bag may rub and wear on the brake or mudguard. To avoid this a kit bag support should be fitted. A suitable support can be purchased from your dealer for a few shillings.

Care of Tyres

CORRECT RIM SIZES. Tyres can only be fitted to the rims for which they are designed. All covers are marked with the size which is also stamped on the rim.

INFLATION PRESSURES. To obtain maximum mileage tyres should be inflated hard. Running a tyre in an under-inflated condition causes rapid tread wear and early failure of the casing. This is particularly important with lightweight types. Under-inflation also makes the machine hard to propel.

USE OF BRAKES. Hard braking causes excessive tyre wear, therefore only use brakes fully in an emergency.

OIL AND PARAFFIN. Oil and Paraffin must not be allowed to come into contact with tyres, or to run along the spokes and reach the tube through the spoke holes in the rim. Both have an immediate and adverse effect upon rubber.

FITTING. See that the rim tape is correctly positioned in the centre of the rim and is not loose. Slightly inflate the inner tube and place it within the cover. Pass the valve through the valve hole and push the first wire edge on to the rim. Now commence to fit the second wire edge at a point diametrically opposite the valve. Keep the wire down in the well of the rim and gradually place it in position, working a little on each side and keeping the wires in the rim well. The last few inches may be gently levered over with a small tyre lever or preferably pushed over by hand. Next, inflate a little and make quite certain that the cover is correctly seated on the shoulders of the rim by pushing it away from the rim with the fingers. When released, the cover should spring back on to the rim shoulder. Fully inflate and tighten the rim nut. Finally, check for truth by rotating, if not, repeat instructions above.

REMOVAL. Completely deflate by removal of all valve parts. Push the two wire edges off the shoulder of the rim right down into the well. With a small tyre lever, lift a portion of the wire edge near the valve over the side of the rim. The remainder will then come over quite easily. The inner tube and cover can then be removed without difficulty.

REMOVAL FOR REPAIR. After repairing a puncture examine inside of the cover and ensure that the cause of the trouble is removed. If the canvas is split it should be repaired. If the rear wheel is not removed from the machine during repair, see that the inner tube does not become smeared with oil from the chain.

CLEANING. The best method to maintain White Side Wall Tyres in good condition is as follows :—

1. Brush with soap and water—preferably warm—using a small brush.
2. If very dirty, use a mild abrasive powder, e.g. finely ground pumice.
3. Detergents may be used instead of soap, but do not use both soap and detergent together.

ON NO ACCOUNT USE PETROL, GASOLINE, NAPHTHA, PARAFFIN, KEROSENE OR ANY OTHER SOLVENT OF RUBBER. REMEMBER THAT THE FITTING OF A MOTOR ATTACHMENT NULLIFIES THE GUARANTEE GIVEN WITH THE MACHINE.

NATIONAL ENGINEERING AWARD

*The Products of
Raleigh Industries Limited*

*are made in the
World's largest
and most up-
to-date Cycle
Factory, where
employees enjoy
all benefits re-
sulting from
National Engin-
eering Awards.*



Ball Bearing Chart

Model	Location	Symbol	Size	No. in each Race	Total
Carrier	Head—Top and Bottom...	329	3/16"	21	42
Tricycle	Head—Top and Bottom...	328	1/8"	28	56
All other models	Head—Top and Bottom...	328A	5/32"	25	50
All models	Bottom Bracket	330	1/4"	11	22
Tricycle	Pedals	328A	5/32"	10 (outer)	13 (inner)
R.R.A.	Pedals	328	1/8"	12	
All other models	Pedals	328A	5/32"	11	
Carrier and Heavy Rider	Front Wheel	330	1/4"	8	16
Tricycle	Rear Wheel	330	1/4"	8	16
	Front Wheel	328A	5/32"	11	22
	Rear Axle... ..	329	3/16"	16	32
All other models	Front Wheel	329	3/16"	10	20
	Rear Wheel	330	1/4"	8	16

Bicycle Identification Form

You should complete this form and keep it safely for production to the police should your bicycle be lost or stolen.

Owner's Name.....

Address.....

Lady's or Gent's..... Machine No..... Date Purchased.....

Make and Frame Size.....

Colour..... Cycle Lock Key No.....

Dealer from whom purchased

Raleigh Industries 'All-purpose' Oil

THIS oil has been specially blended by R.I. chemists for use on R.I. products. It is the best lubricant for all bicycle bearings and for the finer mechanism of Sturmev-Archer Hubs.



Raleigh Industries oil is packed in tins incorporating a patent lubricating nozzle as illustrated.

Available from all R.I. Dealers.

**ALWAYS USE GENUINE RALEIGH INDUSTRIES
SPARES FOR REPLACEMENT PURPOSES
OBTAINABLE FROM YOUR R.I. DEALER**

Printed in England
by A. G. Reynolds & Co., Ltd., London, S.W.1.

S.2362



THIS
RALEIGH
CYCLE

was made in the World's largest and most up-to-date cycle factory where employees enjoy all benefits of National Engineering Awards.

THE RALEIGH CYCLE COMPANY LTD.
Nottingham, England.

A Product of Raleigh Industries Ltd.

Date.....M/C. No.....

Owner's Name.....

Address.....

.....

Dealer.....

S 9175 (A)

KEEP THIS GUARANTEE AND MAINTENANCE BOOK FOR FUTURE REFERENCE



RALEIGH

Guarantee

All RALEIGH bicycles and tricycles are guaranteed against defects of manufacture for a period of 12 months from the date of sale provided they remain during that period the property of the first retail purchaser. This Guarantee does not apply to damage caused by wear and tear, misuse or neglect. The employment of a motor-attachment constitutes misuse for the purpose of this Guarantee.

All conditions or warranties implied by statute or otherwise as to the quality or fitness for the purpose of cycling are hereby excluded. THE LIABILITY WHICH WE ACCEPT UNDER THIS GUARANTEE IS LIMITED TO THE FREE SUPPLY OF A NEW PART IN EXCHANGE FOR THE PART WHICH MAY HAVE PROVED DEFECTIVE, OR AT OUR DISCRETION TO THE REPAIR OF THE ORIGINAL PART, EXCLUDING IN EITHER CASE THE COST OF FITTING, AND DOES NOT EXTEND TO ANY RESULTING LOSS OR INJURY.

If a defective part shall be found in any of our machines within the period specified above it must be sent to us carriage paid with a request that it be replaced free of charge under the Guarantee. The number of the bicycle (stamped on the Seat Lug of the Frame) or tricycle (stamped underneath the bottom bracket), the name of the Dealer from whom it was purchased and the date of purchase must also be stated.

This Guarantee extends only to those bicycles or tricycles which are purchased either direct from us or from one of our duly appointed Dealers and does not apply to bicycles or tricycles which have been used for hiring out purposes or from which our Trade Mark or manufacturing numbers have been removed.

This Guarantee applies only to those parts of the bicycle or tricycle manufactured by us and in the case of defects in components such as tyres, rims and saddles, the purchaser should refer to the respective manufacturers of these components.

KEEP THIS GUARANTEE AND MAINTENANCE BOOK FOR FUTURE REFERENCE

IceniCAM Information Service



www.icenicam.org.uk