

**JAWA 50**

**TYPE 20, 21, 23A**

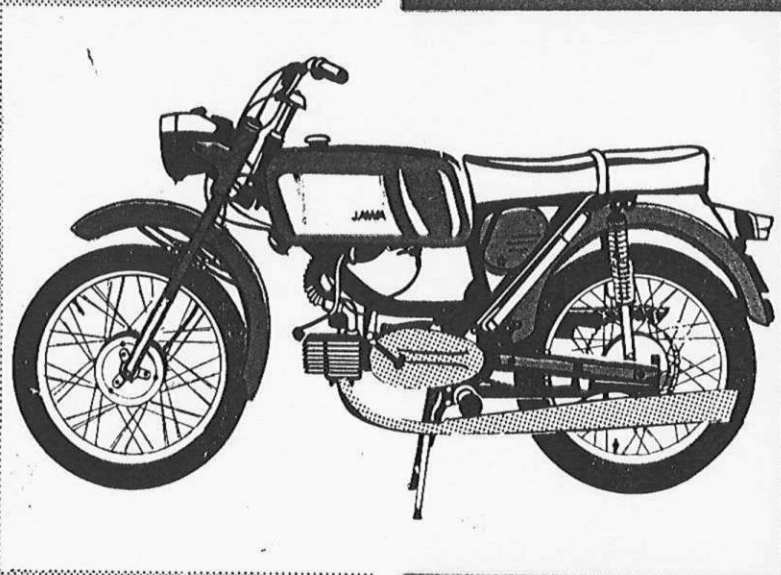

**WORKSHOP  
MANUAL**

# WORKSHOP MANUAL

**Jawa 50, type 20**

**Jawa 50, type 21**

**Jawa 50, type 23A**

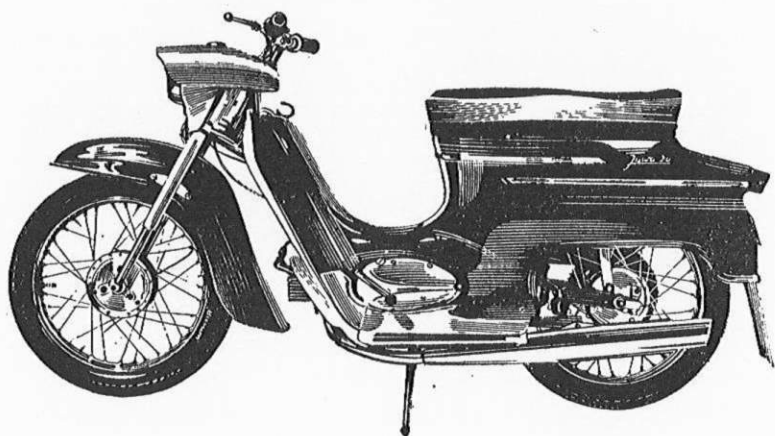

Manufacturer: Považské strojárne, n. c., Považská Bystrica

Export: Motokov ● Praha ● Czechoslovakia

## TABLE OF CONTENTS

	Page
<b>I — Technical characteristics and maintenance</b> — — — —	4
1 — Technical data of Jawa 50, types 20, 21 and 23 A — — — —	4
2 — Piston and cylinder grading — — — —	6
3 — Grading table for the crankpin bearing assembly — — — —	7
4 — Vehicle maintenance table — — — —	8
5 — Lubrication chart — — — —	11
 <b>II — Undercarriage</b> — — — —	 13
6 — Removing the front wheel — — — —	13
7 — Removing the rear wheel — — — —	15
8 — Change of bearings in the wheels — — — —	15
9 — Dismantling the brakes — — — —	15
10 — Dismantling the rear chain wheel and change of bearings — — — —	15
11 — Disassembly and assembly of the cowls — — — —	16
12 — Dismantling the headlamp — — — —	18
13 — Dismantling the handlebars — — — —	18
14 — Dismantling the headlamp guard — — — —	18
15 — Dismantling the fork from the frame — — — —	18
16 — Dismantling the sliders from the front fork shoulders — — — —	18
17 — Dismantling the rear telescopic shock absorbers — — — —	20
18 — Dismantling the rear swinging fork — — — —	20
19 — Change of speedometer flexible shaft — — — —	27
20 — Change of gas cable — — — —	27
21 — Change of clutch cable — — — —	27
22 — Change of front and rear brake cables — — — —	27
 <b>III — Carburetter</b> — — — —	 29
23 — Disassembly and assembly the carburetter — — — —	29
24 — Cleaning and maintenance of carburetter — — — —	29
 <b>IV. — Engine</b> — — — —	 31
<b>A — Disassembly and assembly without removing the engine from the frame</b> — — — —	31
25 — Dismantling the head and cylinder — — — —	31
26 — Change of piston rings — — — —	31
27 — Disassembly and assembly of piston — — — —	32
28 — Dismantling the cylinder and the head — — — —	32
29 — Disassembly and assembly of starting and shifting levers — — — —	33
29a — Dismantling the R. H. cover — — — —	33
30 — Disassembly and assembly of secondary chain wheel — — — —	33
31 — Advanced ignition adjustment — — — —	34

32	—	Magneto disassembly and assembly	—	—	—	—	35
33	—	Dismantling the primary transmission and the clutch	—	—	—	—	36
34	—	Change of the cork inserts	—	—	—	—	37
35	—	Change of sealing rings	—	—	—	—	37
36	—	Dismantling the exhaust silencer and carbon deposit removal	—	—	—	—	38
<b>B — Disassembly and assembly as to remove the engine from the frame</b>							
37	—	Dismantling the engine from the frame	—	—	—	—	39
38	—	Dismantling the engine box	—	—	—	—	39
39	—	Dismantling the gear box	—	—	—	—	41
40	—	Dismantling the crank mechanism from the box	—	—	—	—	41
41	—	Repair and centring the crank mechanism	—	—	—	—	44
42	—	Pressing out the bearings from the engine box	—	—	—	—	45
43	—	Change of the bushes	—	—	—	—	46
44	—	Assembly of engine	—	—	—	—	46
45	—	Assembly of bearings and lock rings	—	—	—	—	46
46	—	Assembly of the crank mechanism	—	—	—	—	47
47	—	Assembly of the gear box	—	—	—	—	47
48	—	Assembly of the box halves	—	—	—	—	47
49	—	Assembly of other parts of engine	—	—	—	—	47
<b>V — Electrical equipment</b>							
50	—	Electric energy source and electrical equipment connection	—	—	—	—	48
51	—	Ferrite magdynamo	—	—	—	—	48
52	—	Ignition	—	—	—	—	49
53	—	Lighting and sound signalisation	—	—	—	—	52
<b>VI — Failures and their clearing</b>							
54	—	Small engine output	—	—	—	—	53
55	—	Seizing and whistling in the engine	—	—	—	—	53
56	—	The engine knocks	—	—	—	—	54
57	—	Carburettor failures	—	—	—	—	54
58	—	Gear shift failures	—	—	—	—	55
59	—	Defects of clutch and its adjustment	—	—	—	—	56
60	—	The defects of the undercarriage	—	—	—	—	57
61	—	Ignition defects	—	—	—	—	57
62	—	Defects of lighting	—	—	—	—	58
63	—	Defects of the sound signalling	—	—	—	—	59
<b>VII — Service tools for Jawa 50/20, 21, 23 A motorcycles</b>							
			—	—			60



# I. TECHNICAL CHARACTERISTICS AND MAINTENANCE

## OF JAWA 50, TYPE 20 JAWA 50, TYPE 21 JAWA 50, TYPE 23A

### Weights

Weight of vehicle without fuel	— —	65 ± 2 % kg or 143.3 lbs. ± 2 %
Max. load of front wheel axle	— —	62 kg or 136.7 lbs
Max. load of rear wheel axle	— —	168 kg or 370.4 lbs

### Engine

Engine type	— — — —	20, 21, 23 A — two cycle
Cylinder capacity	— — — —	49.9 cm <sup>3</sup>
Cylinder diameter (bore)	— — — —	38 mm or 1.496 in.
Piston stroke	— — — —	44 mm or 1.732 in.
Compression ratio	— — — —	1 : 9.5
Max. engine output	— — — —	4 HP (2.6 kW) at 6,500 r. p. m.
Kind of scavenging	— — — —	inverted
Basic advanced ignition	— — — —	2.7 — 3 mm
Breaker contact distance	— — — —	0.4 mm
Bearings of engine	— — — —	6202 Ø 15/35 × 11 — 1 pc 6303 Ø 15/42 × 13 — 2 pcs 6004 Ø 20/42 × 12 — 1 pc
Material of cylinder	— — — —	aluminium alloy with grey cast iron insert
Plug	— — — —	PAL 14-8
Carburettor type	— — — —	Jikov 2917 PSb
Main nozzle	— — — —	68
Idling run nozzle	— — — —	38
Diffuser diameter	— — — —	Ø 17 mm
Weight of engine	— — — —	12 kg
Min. specific consumption	— — — —	544 g/kW/h at 5800 r. p. m.
Max. noise level	— — — —	80 dB
Under load	— — — —	of two persons — one person (160 kg) (80 kg)
Average consumption	— — — —	3.2 l/100 km 2.3 l/100 km.
Max. speed	— — — —	50 km/h. 65 km/h.
Max. gradient	— — — —	15 % 25 %

### Gears

Number of gear ratios	— — —	3
Clutch	— — — —	twin-disk clutch in oil bath
Primary chain transmission	— —	3/8" × 3/8" — 44 links
Secondary chain transmission	— —	1 × 12.7 × 5.21 mm × 111

				I	II
Overall ratios:	1-st gear ratio	—	—	1:27.72	30.03
	2-d gear ratio	—	—	1:15.18	or 16.44
	3-d gear ratio	—	—	1:10.27	11.13

### Frame

Front wheel suspension	—	—	—	telescopic fork
Front suspension stroke	—	—	—	90 mm
Rear suspension	—	—	—	swinging fork with two telescopic shock absorbers
Rear suspension stroke	—	—	—	85 mm

### Brakes

Drum shoe dia	—	—	—	125 mm
Band lining width	—	—	—	20 mm

### Wheels

Version	—	—	—	—	identical in the front and in the rear, mutually exchangeable
Size of rim	—	—	—	—	1.5A×16"
Size of tyre	—	—	—	—	2.75×16"
Drums	—	—	—	—	all hub version
Wheel bearings	—	—	—	—	6201 Ø 12/32×10—4 pcs
Bearing of second transmission gear	—	—	—	—	6004 Ø 20/42×12-1 pc
Pressures: front tyre	—	—	—	—	1.5 atm (147k Pa)
rear tyre	—	—	—	—	1.9 atm (186k Pa)

### Fuel tank

Capacity	—	—	—	—	5.5 lit. (Jawa 50/23A — 8 lit.)
Speedometer	—	—	—	—	Ø 48 mm, 0—80 km/h.

### Electric equipment with accessories

Ignition	—	—	—	—	6 V magneto
Lighting-output-front light	—	—	—	—	25 W
rear light	—	—	—	—	5 W
Generator	—	—	—	—	6 V, 20 W magneto
Ignition coil	—	—	—	—	8 V, 02—9210.30
Condenser	—	—	—	—	0.27 µF

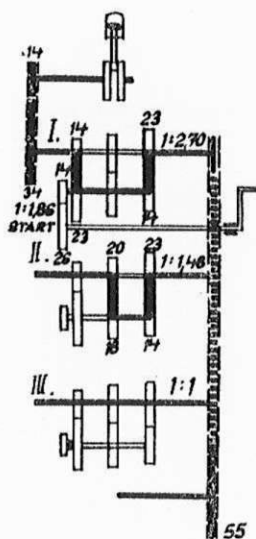

Jawa 50, type 20, 21 and 23 A

Fig. 2 — Transmission diagram

## 2. Piston and cylinder grading

The pistons and the cylinder barrels are graded in three groups (A, B, C) according to their diameters. The letter indicating the grading is stamped on the parts. After re-boring and honing the cylinder barrel the upper contact area is to be marked with the grading letter and drawing number. The cylinders are re-bored and honed to the tabulated diameters.

The piston marking must agree to the cylinder marking.

### Cylinder grading

	A	B	C
Normal cylinder	38.00 + 0.006	38.006 + 0.005	38.011 + 0.005
1-st rebore	38.25 + 0.006	38.256 + 0.005	38.261 + 0.005
2-d rebore	38.50 + 0.006	38.506 + 0.005	38.511 + 0.005
3-d rebore	38.75 + 0.006	38.756 + 0.005	38.761 + 0.005
4-th rebore	39.00 + 0.006	39.006 + 0.005	39.011 + 0.005

### Piston grading

	A	B	C
Normal piston	37.95 +0.00 -0.01	37.96 +0.00 -0.01	37.97 +0.00 -0.01
1-st rebore	38.20 +0.00 -0.01	38.21 +0.00 -0.01	38.22 +0.00 -0.01
2-d rebore	38.45 +0.00 -0.01	38.46 +0.00 -0.01	38.47 +0.00 -0.01
3-d rebore	38.70 +0.00 -0.01	38.71 +0.00 -0.01	38.72 +0.00 -0.01
4-th rebore	38.95 +0.00 -0.01	38.96 +0.00 -0.01	38.97 +0.00 -0.01

The dimension for grading the pistons is checked 32 mm from the piston base.

### 3. Grading table for the crankpin bearing assembly

Connecting rod		Rollers						
		A	B	C	D	E	F	G
Pins	1	VII	VI	V	IV	III	II	I
	2	VI	V	IV	III	II	I	
	3	V	IV	III	II	I		
	4	IV	III	II	I			
	5	III	II	I				

### Assembly groups

Connecting rod	Roller	Crankpin
I 25.194+0.002	A 2.5 -0.002	1 20.200-0.002
II 25.196+0.002	B 2.499-0.002	2 20.198-0.002
III 25.198+0.002	C 2.498-0.002	3 20.196-0.002
IV 25.200+0.002	D 2.497-0.002	4 20.194-0.002
V 25.202+0.002	E 2.496-0.002	5 20.192-0.002
VI 25.204+0.002	F 2.495-0.002	
VII 25.206+0.002	G 2.494-0.002	
	H 2.493-0.002	
	I 2.492-0.002	

The example of grading according to the table. Provided the connecting rod  $\varnothing$  25.198-0.002 (group III) and the crankpin  $\varnothing$  20.192-0.002 (group 5) are to be used, for pairing use the  $\varnothing$  2.496-0.002 rollers (group E).

#### 4. Maintenance table

	Operation
1.	Thorough cleaning of the scooter
2.	Check tyre pressure — inflation
3.	Check the lights and buzzer
4.	Check and adjust the brakes
5.	Check the sparking plug, clean it and set the point gap
6.	Decarbonise the exhaust silencer
7.	Decarbonise cylinder head, piston, exhaust port and exhaust pipe
8.	Clean the induction silencer (9)
9.	Check and tighten all leads in their terminals Check lead insulation
10.	Check and tighten spoke nipples
11.	Check and tighten all surface screws, bolts, nuts and pins, incl. engine fastening studs
12.	Check and clean the carburetter and the fuel tap
13.	Check and adjust the clutch
14.	Clean the contact breaker points and check the ignition advance
15.	Lubricate the contact breaker arm pin and felt (7)
16.	Clean and lubricate the rear chain on the machine (10)
17.	Check the rear chain tension
18.	Remove the rear chain, wash and lubricate it with graphited grease. Fit and adjust (10)
19.	Lubricate the hand lever pins (2) and foot brake pedal pin (3)
20.	Lubricate the telescopic front fork (4)
21.	Lubricate the wheel ball bearings (6)
22.	Lubricate the twist grip (8)
23.	Check and top up oil in the gearbox (5)
24.	Change the oil in the gearbox (5)
25.	Lubricate the throttle, clutch and brake control cable (14)
26.	Lubricate the kickstarter pedal pin (12), centre stand pin (13), speedometer drive (17), brake cams (11), and speedometer flexible shaft (16)
27.	Lubricate the steering head ball bearing (15)
28.	Check the operation of the pivoted rear fork dampers, if necessary, top up the damper liquid (18)

Mileage covered:							Note
0	1000	3000	5000 15000	7500 17500	10000 20000	12500 22500	
	X	X	X	X	X	X	If necessary Before every ride
X	X	X	X	X	X	X	
X	X	X	X	X	X	X	
		X	X	X	X	X	If necessary First time after 900 miles
	X	X	X	X	X	X	
		X	X	X	X	X	Every 600 miles
	X	X	X	X	X	X	
	X	X	X	X	X	X	
X	X	X	X	X	X	X	
	X	X	X	X	X	X	
	X	X	X	X	X	X	
	X						Every 500-600 miles
	X						
	X	X	X	X	X	X	Every 500-600 miles
	X	X	X	X	X	X	
	X	X	X	X	X	X	Every 500-600 miles
X	X	X	X	X	X	X	
		X	X	X	X	X	Every 500-600 miles
		X	X	X	X	X	
X	X	X	X	X	X	X	First time after 300 miles
		X	X	X	X	X	
			X		X		
			X		X		
					X		If necessary
					X		

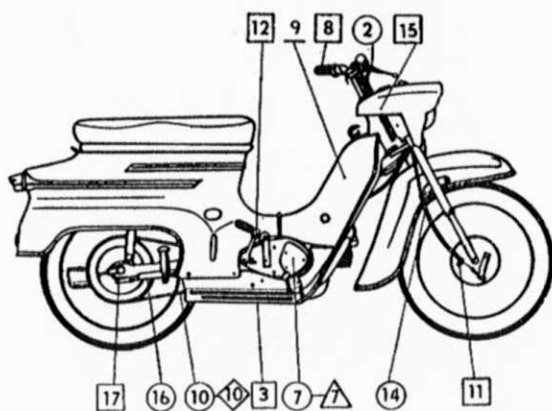
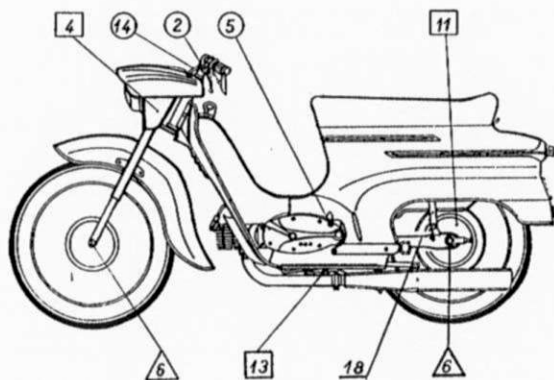

Fig. 3 — The Lubrication chart may be used for all the types

5 — Lubrication chart

Miles (km) covered	○	◻	◻	△
	<p><i>In hot weather:</i>                      Gearbox oil PP 7                      Castrol SAE 50                      Shell Spirax 90 E. P.  <i>In cold weather:</i>                      Gearbox oil PP 7                      Castrol SAE 20-30                      Shell Spirax 90 E. P.</p>	<p>Grease A OO                      Castrolase CL                      Castrolase Graphited                      Shell Retinax A</p>		<p>Grease AV2                      Castrolase heavy</p>
Lubrication point				
560-600 (900-1000)	<p>2 Hand lever pins                      5 Gearbox (topping up)                      10 Rear chain (add grease)</p>		<p>3 Foot brake pedal pin                      4 Telescopic front fork</p>	
1,500-1,600 (2,400-2,600)	<p>7 Contact breaker arm pin (oil drop)                      14 Control cables</p>		<p>8 Twist grip                      10 Rear chain (place in hot lubricant)</p>	<p>7 Contact breaker felt (saturate with grease and oil)                      6 Wheel bearings</p>
3,000-3,200 (4,800-5,200)	<p>16 Speedometer flexible shaft (after detaching oil some drops)</p>		<p>11 Brake cams                      12 Kickstarter pedal pin                      13 Centre stand pin                      15 Steering head (grease after dismantling and washing)                      17 Speedometer drive gear</p>	
	<p>18 Rear suspension telescopic dampers — top up, if necessary, 30 c. c. of damper liquid per damper (Shock Oil, Damper Oil, X 100 20 W). When dismantling grease the damper spring with grease (Castrolase CL, Shell Retinax A), Change oil once in two years.</p>			
6,200 (10,000)	<p>5 Gear-box — during running-in after the first 300 miles (500 km) and next 6,200 miles (10,000 km) change the oil.</p>			
	<p>Fuel mixture:                      During running in (up to 900 miles — 1500 km) petrol with oil at a ratio of 20 to 1 (petrol with Castrol SAE 40-50 or Shell at a ratio of 20 to 1). After running in period (having covered 900 miles — 1500 km) with Castrol SAE 40-50 or Shell at a ratio of 24 to 1 and 30 to 1.</p>			



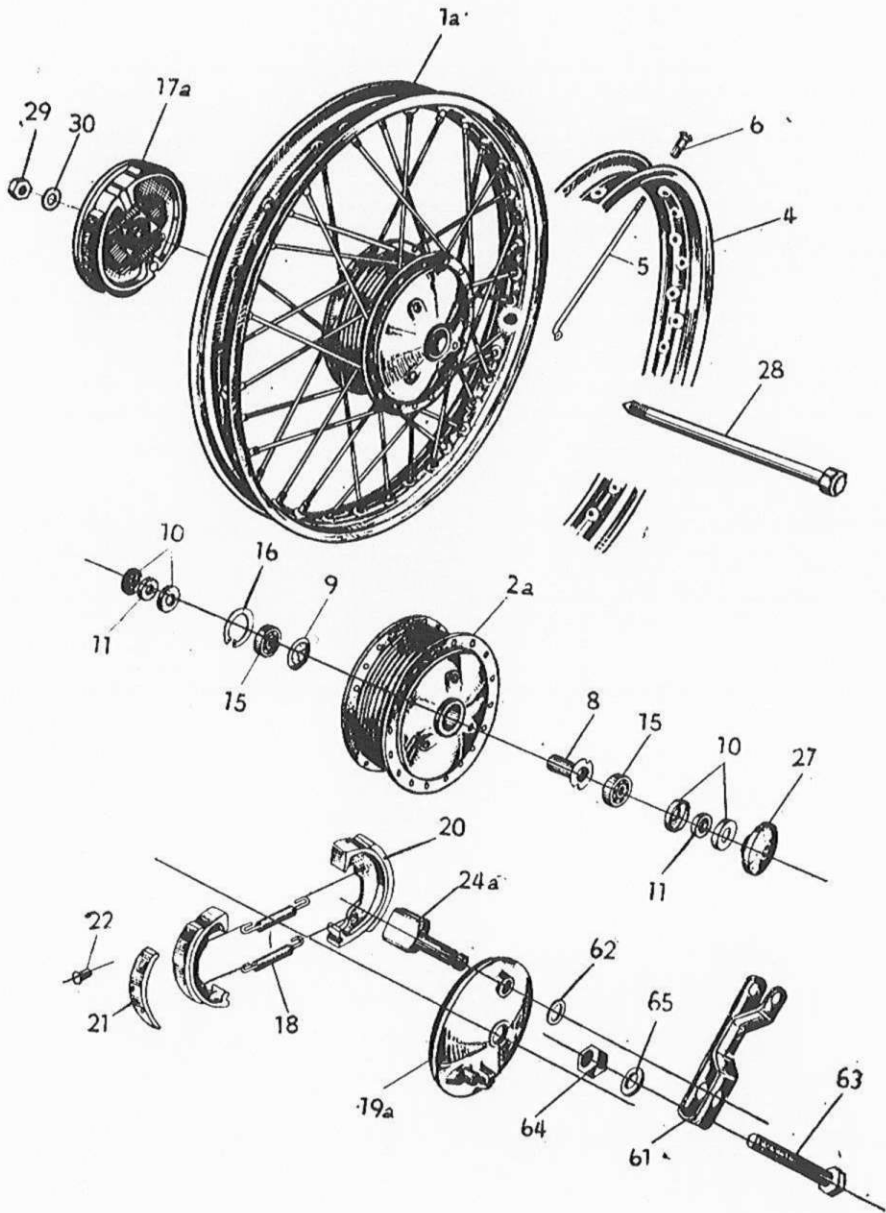

Fig. 4

## II. UNDERCARRIAGE

### 6. Removing the front wheel (fig. 4)

Unscrew the nut (29) with help of socket spanner (19), remove the elastic washer (30) and get out the wheel axle (28). By a slight lowering the wheel downward remove the brake drum cover pin (17) from the reaction catch and remove the wheel. The brake cover together with shoes (17) remains on the front brake cable.

### 7. Removing the rear wheel (fig. 6)

Dismantle the axle with nut as with the front wheel (chapter 6). Loosen the cable bowden of the rear brake from beneath the catch (from inside the pivoted fork). The reaction catch (27) at the L. H. side pull out, backward. Remove the wheel from the engaging pins of the chain wheel (32), shift it to the upper rear guard cover, remove the brake cover from the wheel and put it aside freely through the pivoted fork L. H. arm. Lift the motorcycle by the handle on the rear cowling to enable the free falling out the wheel.

Take care, while assembly of rear wheel on the motorcycle, to avoid the reversed assembly of the reaction catch (fig. 5).

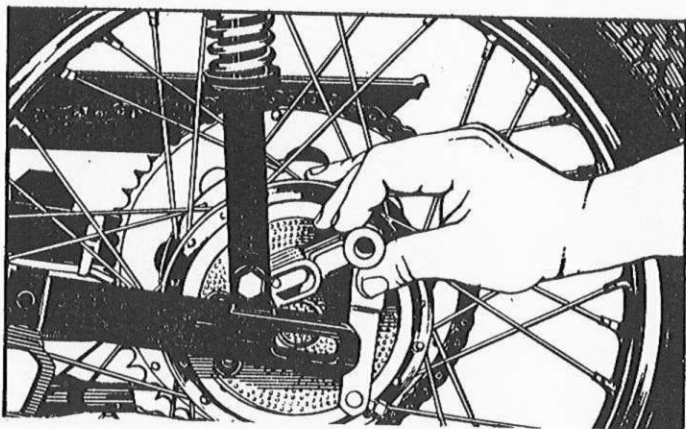
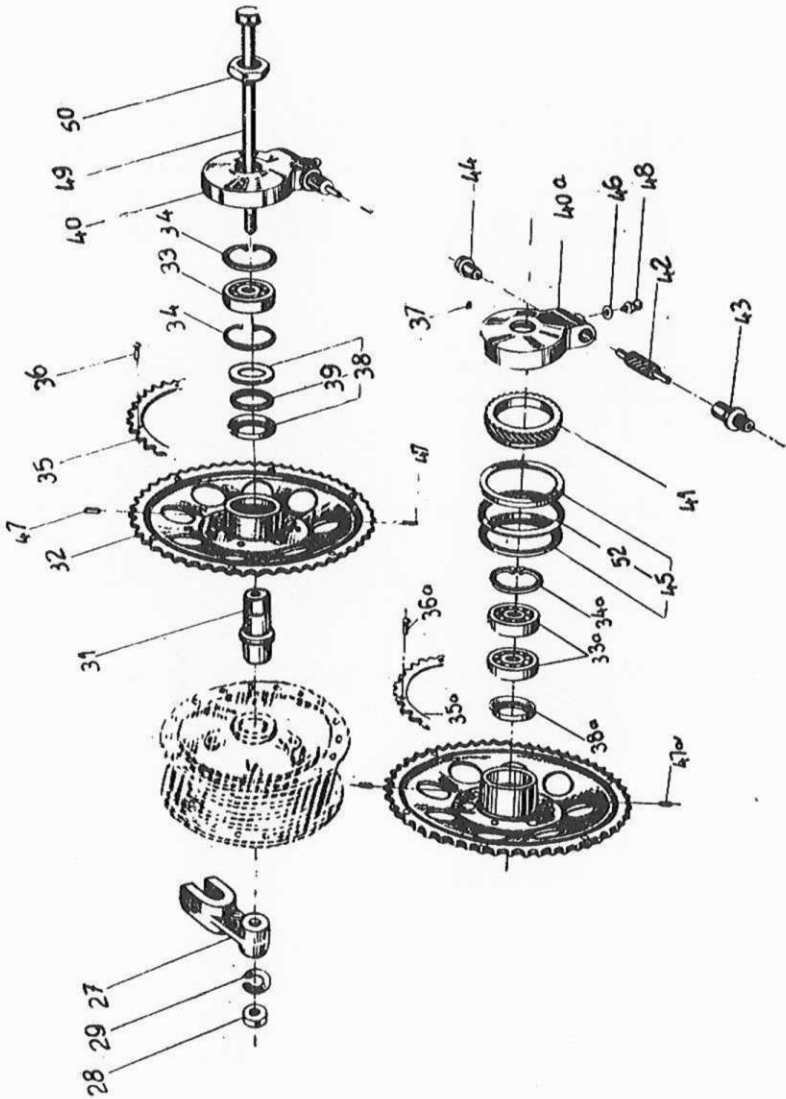

Fig. 5



### 8. Change of bearing in the wheels (fig. 4)

The change of bearing is the same in both wheels. Remove the packing (10) from both wheel hub sides. Remove the lock ring (16) from the L. H. hub side with help of pliers. Force out bearing. Proceed in the same way when assembly of R. H. bearing (15). After dismantling clean all the parts from the ancient grease and wash them in petrol, should the bearings be worn, change them by new ones. When assembly of bearings proceed in the following way. To make easier the assembly of bearings heat up slightly the brake drum hub to abt. 80 °C. Insert the bearing onto the L. H. side, lock this one by the lock ring and introduce the packing with felt. Press the vaseline into the hub, introduce the spacer, the R. H. bearing with packing and felt. Impregnate the felt packing with engine oil before assembly.

Fig. 7

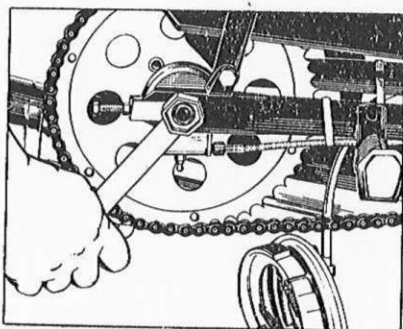

### 9. Dismantling the brakes (fig. 4)

After dismantling the brake cover (17a) from the wheel hub expand the brake cams (20) and remove them from the brake cover (19a). Proceed vice versa when assembly. Grease slightly the pin and the brake cam.

### 10. Dismantling the rear chain wheel and change of bearings (fig. 6)

The rear chain wheel is able to be dismantled after removing the rear wheel from the vehicle. Disconnect the secondary chain and the flexible shaft from the speedometer drive (40). With help of № 27 key unscrew the ring nut (50) and remove the complete chain wheel (32) from the pivoted fork R. H. shoulder. Remove the speedometer drive from the chain wheel hub (40) and with a slight knocking with wooden hammer drive the hub (31) out of bearing. Remove the packing (38) together with felt (39). With help of pliers remove the lock ring (34). With N 16 puller remove the bearing (33). Proceed vice versa when assembly. Grease the bearings and impregnate the felt with oil.

## 11. Disassembly and assembly of the cowls (fig. nos. 8, 9)

### a) Front cowl

Having rotated partially the safety pin backward, grasp the front cowl (1) on the lower part which is to be slightly extended and lifted (fig. 8). Pull then the whole cowl backward till a hook in its upper part is thrown out of frame hole.

### b) Protective front shield

Proceed in the following way while dismantling:

Unscrew the headlamp screw and tilt the headlamp. Disconnect the flexible shaft from the speedometer. Unscrew the cable shoe from the sparking plug cable. Pull the flexible shaft and sparking plug cable together with rubber bushing from the protective shield toward the engine. Unscrew each one M5×10 screw on both foot rest sides, fastening the tunnel (17) to the foot rests and remove the tunnel. Unscrew 4 screws in the front shield upper part (16), 5 M5×10 screws in the lower part, fastening the front shield to the frame and floors and remove the front shield.

### c) Rear cowl

Unscrew three M6×10 screws beneath the saddle in its upper part and remove the saddle. Disconnect the rear light yellow cable in the bakelite box above the engine. After unscrewing two M6 nuts in the rear cowl upper part, one M6×10 screw, fastening the cowl to the frame and four M5×10 screws with nuts fastening the rear cowl part to the floors, remove the cowl by extending it slightly. Proceed vice versa while cowls assembly.

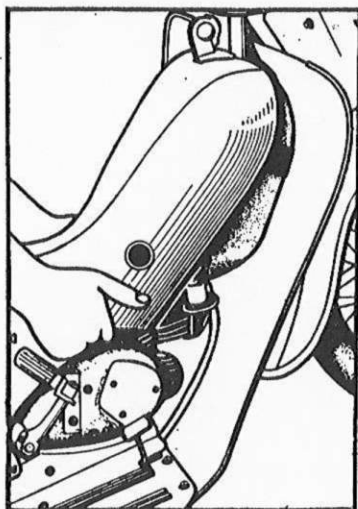

Fig. 8

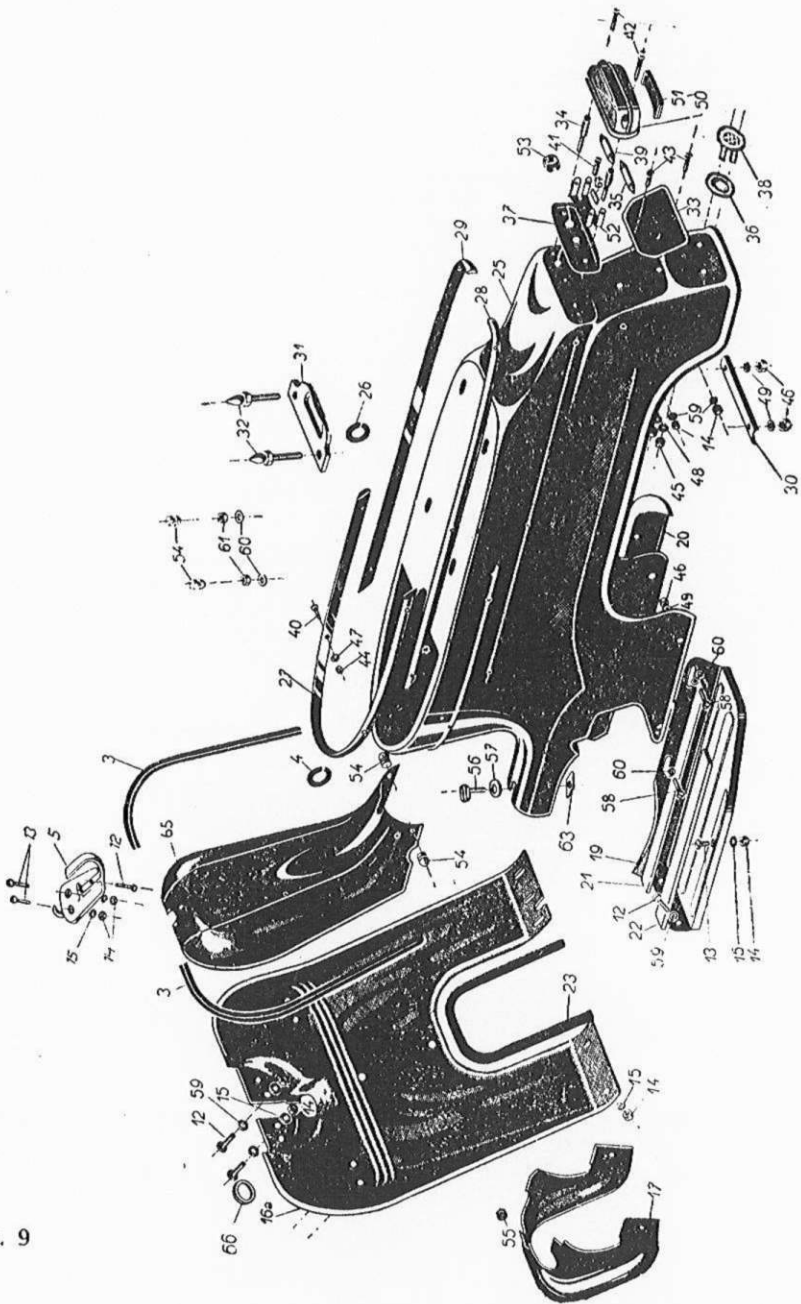

Fig. 9

## 12. Dismantling the headlamp

Unscrew the M5 screw on the frame lower part and tilt the headlamp. Remove the headlamp after rotating partially the bulb holder with cover on the parabola rear part.

## 13. Dismantling the handlebars

Dismantle the handlebars with gas cable bowden. Remove the front cowl, R. H. engine cover and disconnect the gas cable (chapter 23). Dismantle the headlamp (chapter 12) from the cover on the handlebars, from the choke coil and buzzer disconnect the cables leading from the dipswitch on the handlebars. Loosen the handlebars spindle with spanner 10 and knock it down with help of wooden hammer. Pull the handlebars by rotating them slightly together with gas cable and cables. Proceed vice versa while assembly.

## 14. Dismantling the headlamp guard (fig. 10)

While dismantling the headlamp guard, dismount first of all the handlebars and the headlamp. Disconnect then the speedometer flexible shaft in the headlamp guard space and its upper part unscrew two screws fastening the switch box. Disconnect the remaining cable from the buzzer. Unscrew two screws and nuts fastening the headlamp guard to the carrier and remove the headlamp guard.

Proceed vice versa while assembly. See, however, that in the clutch and brake levers are found all the bushes.

## 15. Dismantling the fork from the frame (fig. 10)

Dismantle the front wheel, handlebars and headlamp guard as described in the preceding chapters. Unscrew the M6-nuts (12) and both plugs (24) from both shoulders. Unscrew two M6×7 nuts (11) and remove the cover plate with choke coil. Unscrew 2 nuts (5) and remove the upper carrier (4), the cover plate (2) and the front fork are to be pulled. Take care, however, when pulling the fork from the frame to prevent the steering head balls from to be scattered.

Proceed vice versa while assembly. Grease the balls and pans and tighten the fork with nuts (5) to enable the free rotation of same and to avoid the excessive play.

## 16. Dismantling the sliders from the front fork shoulders (fig. 10)

Dismantle the front wheel. Loosen the tightening band (26) from the rubber cup (27) and by the L. H. rotation unscrew and pull out the slider. Proceed vice versa while assembly. Grease the sliders before to assemble them.

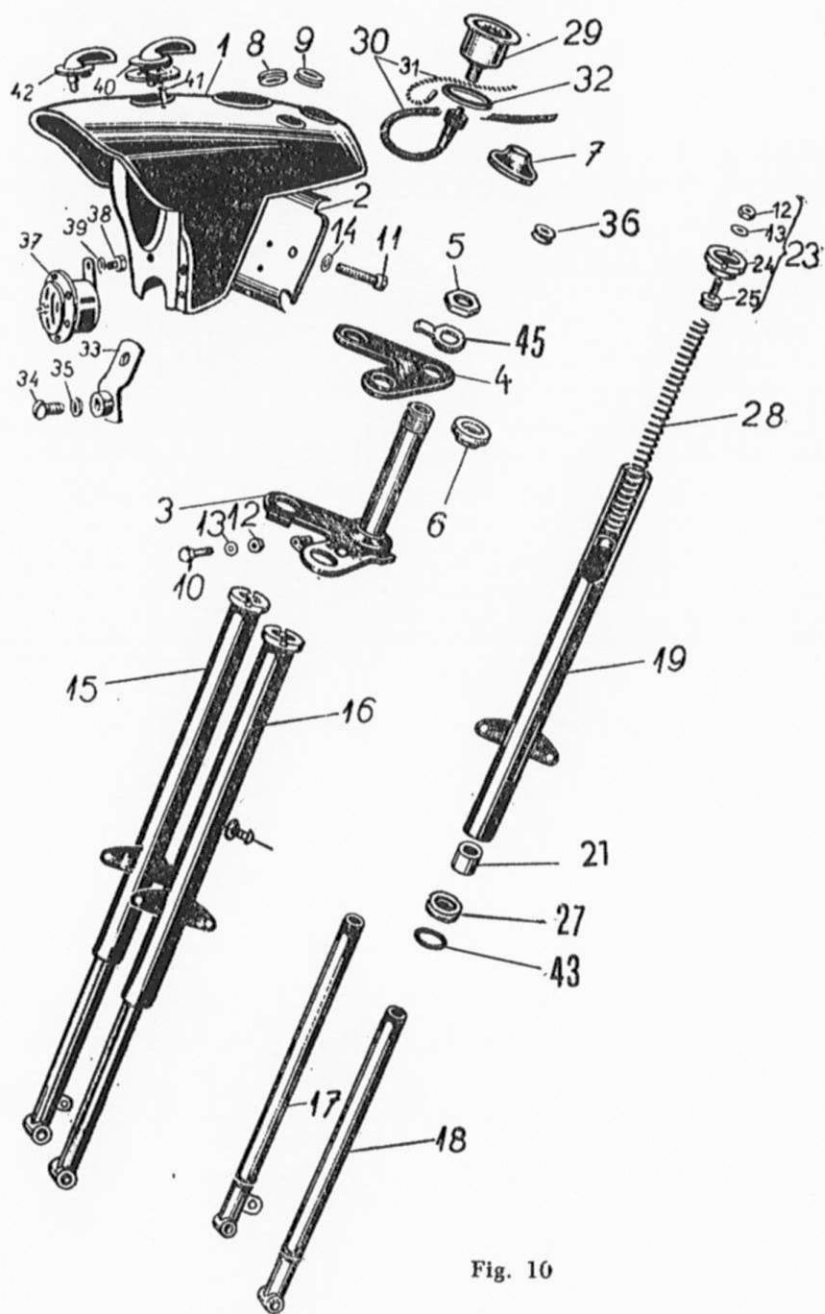

Fig. 10



## 17. Dismantling the rear telescopic shock absorbers (fig. 11)

Dismantle the saddle.

Remove the front cowl.

Dismantle the rear cowl.

Unscrew the screws and nuts with no. 14 spanner which fasten the shock absorbers to the frame and to the swinging fork shoulders and remove the shock absorbers.

Compress the telescopic shock absorber so as to be able to insert the spanner no. 7 into the groove milled in the pull rod locking thus the same. Pull the pin from the suspension and unscrew the suspension.

Pull the spanner from the pull rod grooves and loosen the compressed parts. Remove the upper guard, the spring and the lower guard as well as the rubber stop from the complete cylinder.

Unscrew the complete sealing bush which is to be pulled commonly with complete piston from the complete cylinder. Pour the ancient shock absorber oil from the complete cylinder and wash the cylinder together with piston in the kerosene.

When repair the complete piston or complete sealing bush carry out the dismantling in the following way: remove the complete sealing bush from the pull rod piston. Unscrew the M8 nut on the pull rod lower part and remove the piston together with the cup. Remove two pins locking the plug screw to the bush and unscrew the screw.

Should the shock absorber leak, change the silon ring or two rubber rings from the plug screw or the whole plug screw, if required. Before the assembly of the silon ring on the plug screw warm up the ring in the oil heated up to abt. 150 °C.

Proceed vice versa while assembly. After screwing the nut onto the pull rod, lock the same by clinching the pull rod ends. Before the complete piston assembly charge into the cylinder the prescribed 30 ccm quantity of shock absorber oil.

## 18. Dismantling the rear swinging fork (fig. 12)

Procedure when dismantling the rear swinging fork pin from the frame: Pressing out the rear swinging fork axle is carried out in such a case only, if the frame or the swinging fork are damaged. Since the rear swinging fork axle is pressed firmly in the frame and in the bushes of the swinging fork, it is difficult to be dismantled.

The simplest method of separation is the following one: Saw the rear swinging fork axle in two points marked (see figure). Deburr the axle after sawing. The remaining axle parts remove under hand operated press.

Procedure when pressing-in the insert and swinging fork axle: Into the swinging fork part no. 05-3221 introduce a rubber insert part no. 05-3211 which is to be gently moistured in trichlorethylene before to be inserted.

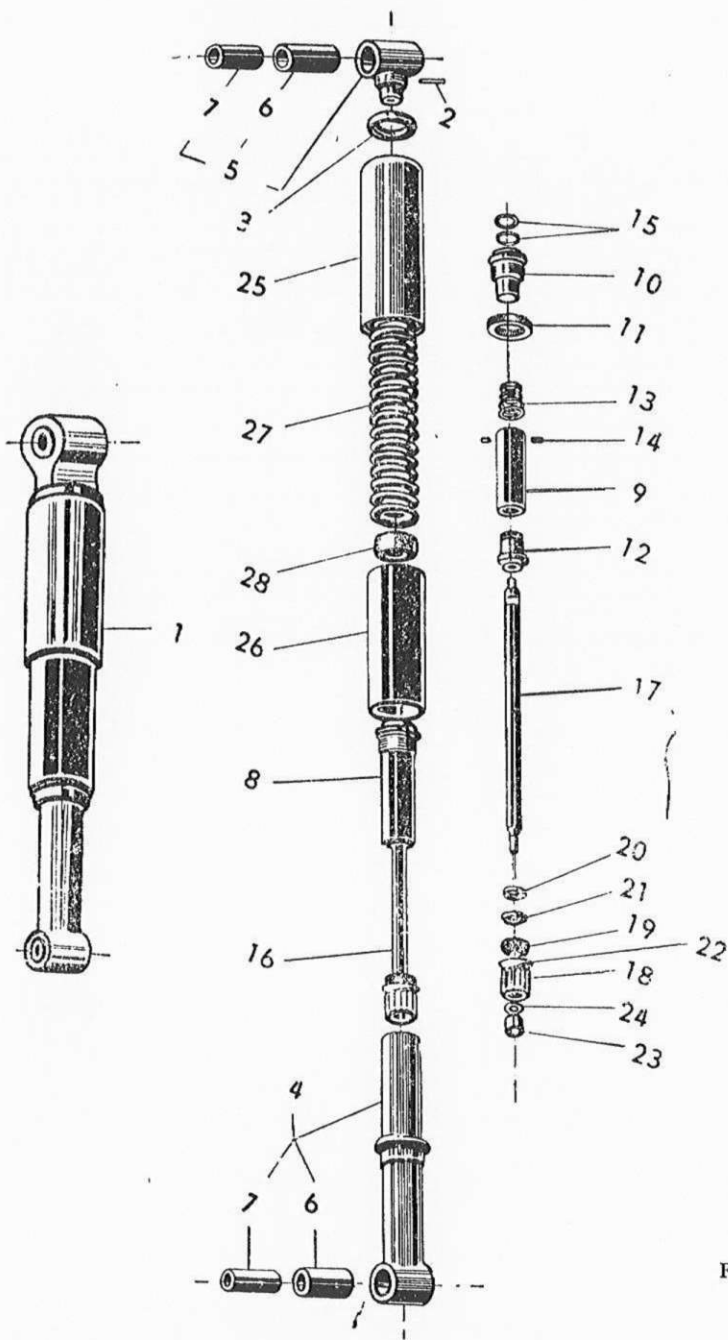

Fig. 11

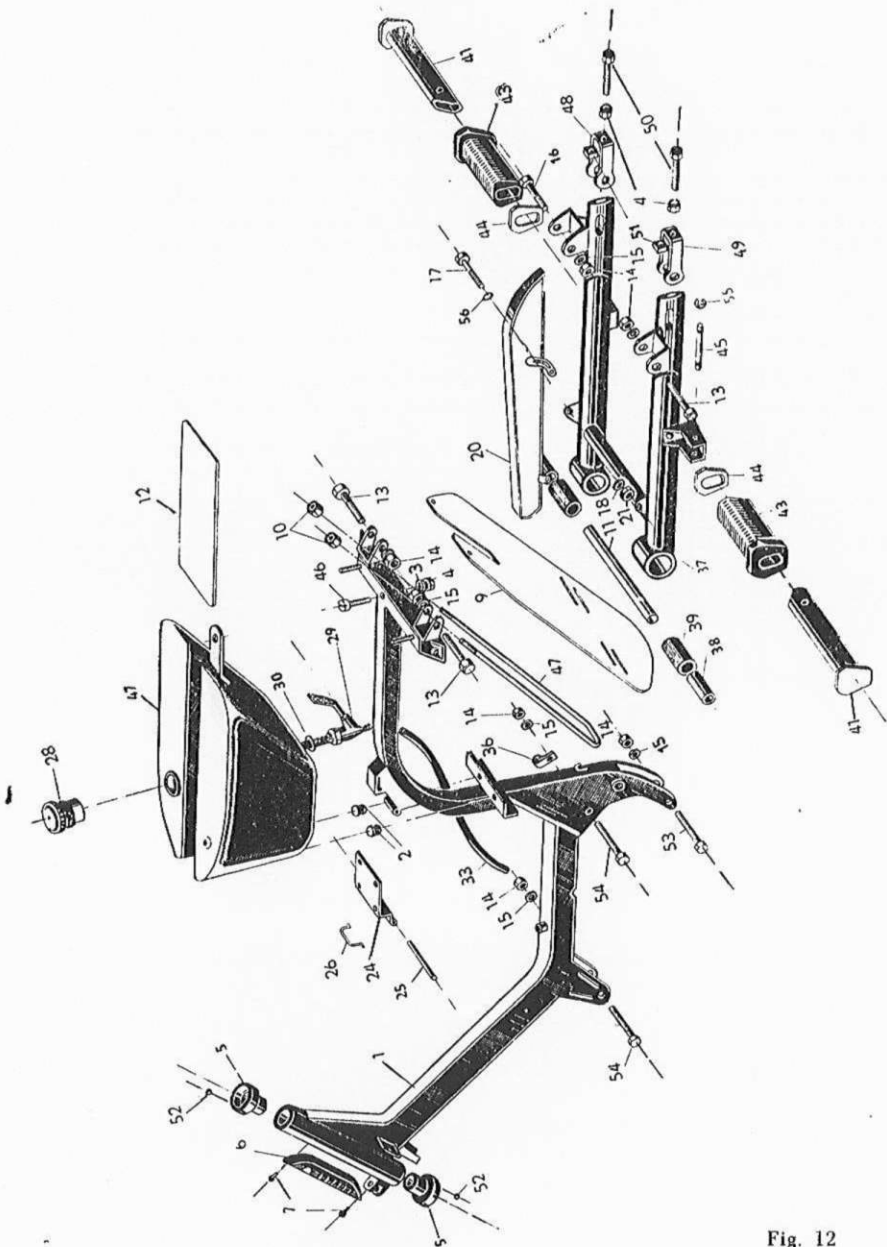

Fig. 12

With help of fixture A and B introduce the bush part no. 05-3210 into the hole in the rubber insert and press in the bush. Slide the stretchers, part no. 05-3001 and the swinging fork onto the frame. Insert the auxiliary pin C into the bushes to guide the parts. Put slightly the swinging fork axle into the bush and press it in the fixture under the press. (Detailed drawings of fixtures are shown in the fig. nos. 13, 13a, 13b).

This work is very difficult and it is not recommended to be carried out without special fixtures as the parts could be destroyed otherwise.

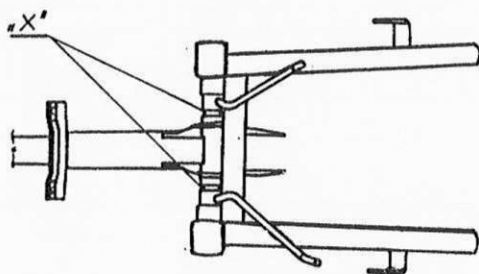
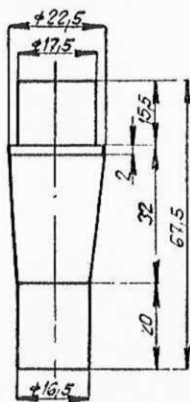
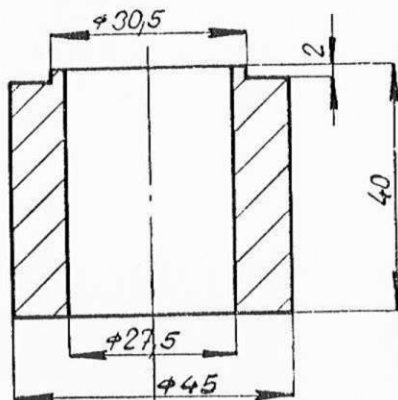

Fig. 13



Part A, from composition 13a



Part B, from composition 13a

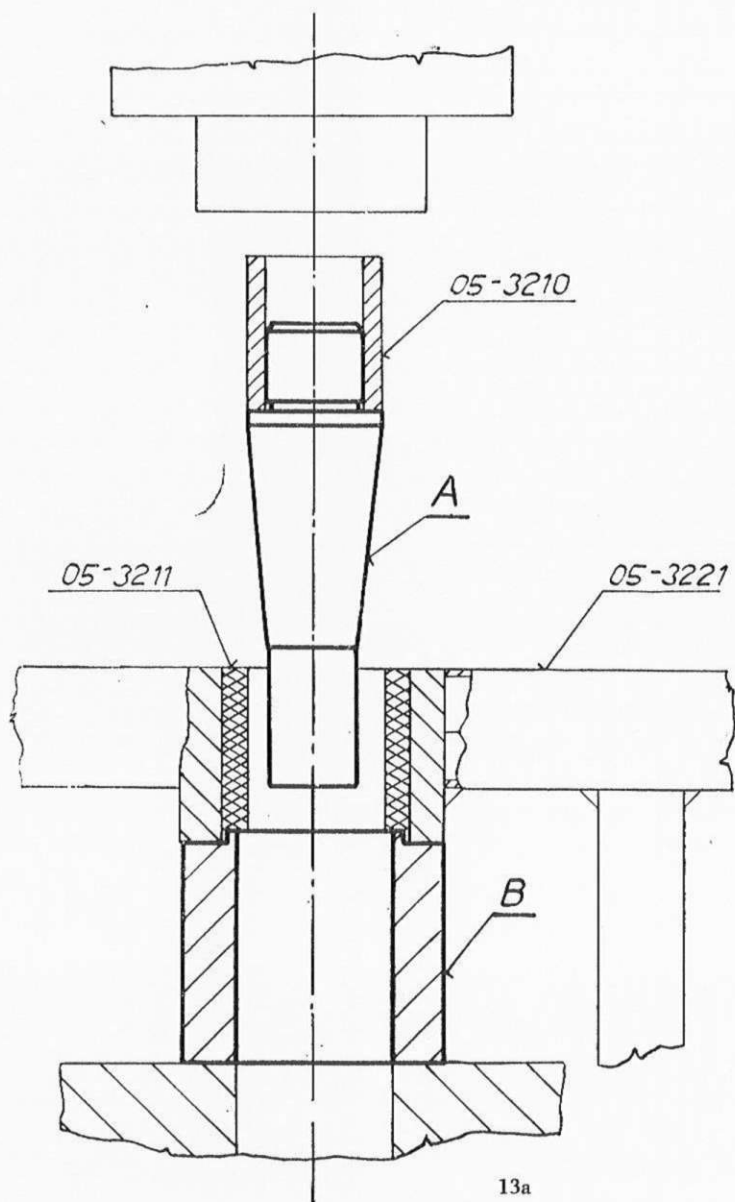

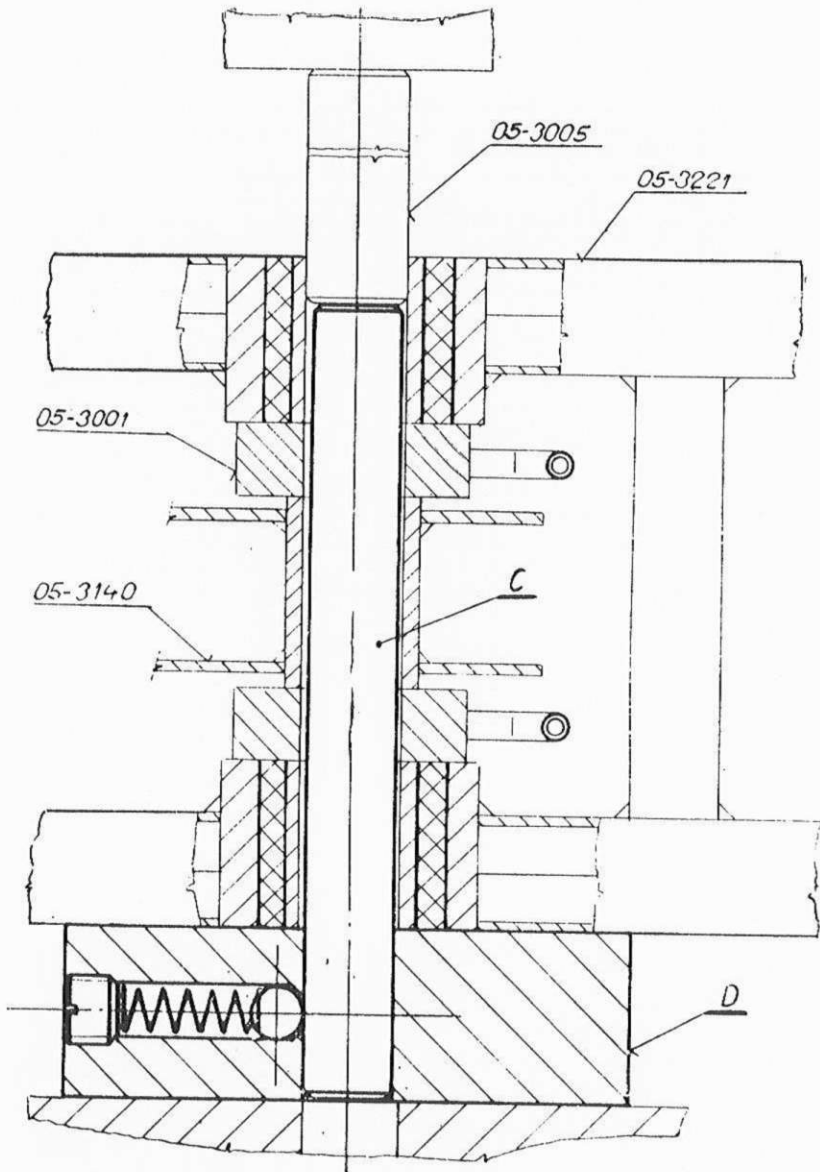

13b

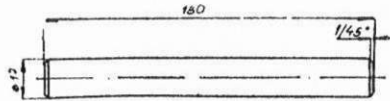

Part C, from composition 13b

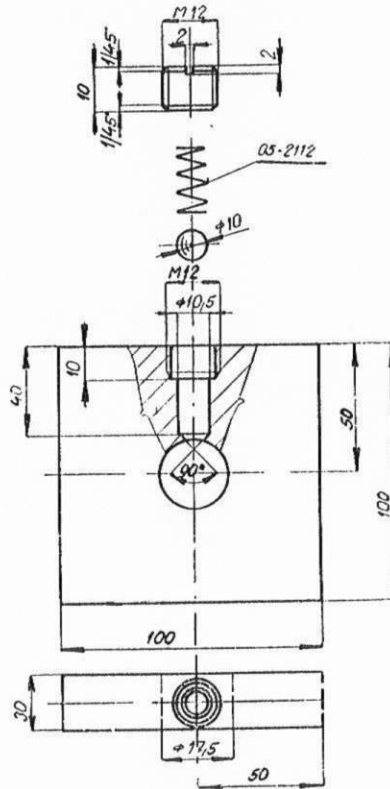

Part D, from composition 13b

### 19. Change of speedometer flexible shaft

Dismantle the front guard and the headlamp. Unscrew the flexible shaft knurled nut from the speedometer in the headlamp guard space and pull the shaft together with bushing toward the engine. Remove the fixing eylet from inside the R. H. swinging fork shoulder. Unscrew the knurled nut from the rear wheel drive box and remove the flexible shaft.

Proceed vice versa when assembly.

### 20. Change of gas cable

Dismantle the headlamp and the front cowl. Disconnect the gas cable on the carburetter (chapter 23). Rotate the gas twist-grip so to be able to loosen the screw through the lateral hole which locks the screw in the handlebars. Pull the grip together with plug. Pull the cable termination from sliding contact and pull the bowden cable with bowden. The assembly is carried out vice versa, greasing, however, the sliding contact and twist grip inner surfaces.

### 21. Change of clutch cable

Dismantle the front cowl, the headlamp and R. H. engine cover. By loosening the screw from the roller pull the cable from disengaging lever. Pull the supporting plate from the clutch lever on the handlebars right side. Proceed vice versa while assembly. The adjustment is carried out as mentioned in the chapter 59.

### 22. Change of front and rear cables

Dismantle the headlamp when changing the front brake cable. Loosen the front brake cable from the lever and pull the cable. Unscrew first of all the set nut on the rear brake cover when changing the rear brake cable bowden. Remove further on the roller from the brake lever and pull the cable bowden. Proceed vice versa when assembly. Oil the cables before assembly in the points given by the table.

Fig. 14

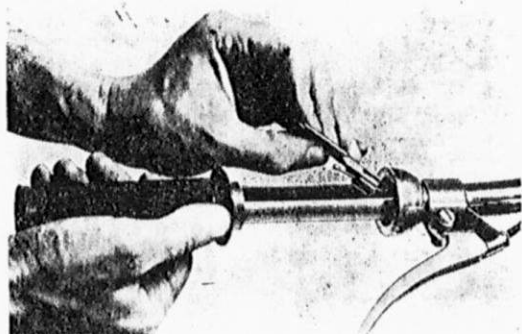



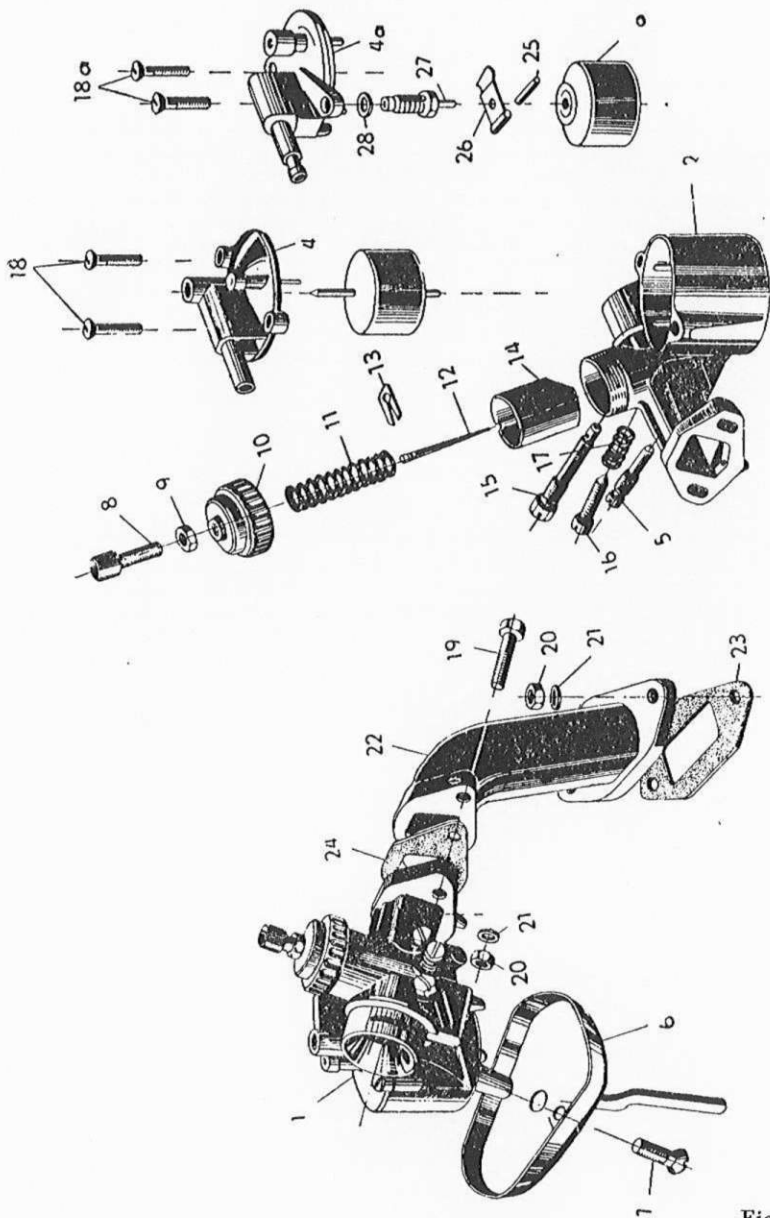

Fig. 15

### III. CARBURETTER

#### 23. Disassembly and assembly the carburetter 2917 PSb (fig. 15)

Remove the front guard (chapter 11).

Shut the fuel supply cock and disconnect the fuel hose from the float chamber cover. Remove the air filter from the diffusor which forms at the same time also the intake silencer. Unscrew the mixing chamber cover (10) on the carburetter which is to be pulled out together with mover (14) from the carburetter body (2).

Disconnect the gas cable terminal from the mover by compressing the spring (11) and pull the mover with spring and cover.

Dismantle the float chamber by loosening two M5 screws (18), remove the cover (4) and pull the float with needle (3).

Unscrew the main nozzle (15) on the carburetter body L. H. side. Unscrew also the idle run nozzle (5) and mover screw (16) with spring (17).

Remove the carburetter body together with the carburetter socket after unscrewing two nuts fastening the carburetter socket to the cylinder.

The intake silencer is to be dismantled after removing the rubber ring and from the silencer jacket a micro-filter is to be taken out.

Proceed vice versa when assembly.

#### 24. Cleaning and maintenance of carburetter (fig. 15)

The cleaning is carried out in the following way. Dismantle the carburetter from the motorcycle (chapter 23). Having dismantled it wash all the parts in the clean petrol. The nozzles and the holes in the carburetter body are to be blown out. The cleaning and the maintenance are carried out according to the maintenance table.

#### Warning:

It is prohibited to clean the nozzle holes and the parts of carburetter body with hard objects (wire).

The carburetter is correctly fixed on the machine from works already. The main nozzle corresponds with correct carburetter efficiency (68). The carburetter is generally provided with two nozzles i. e. with main nozzle 68 (15) and the idle run nozzle no. 38 (5). The mover set screw (16) with spring adjusting the engine idle run is arranged in the center of both nozzles in the carburetter body. The mover needle is adjusted during the running-in on the 3-d notch from upward. The idle run is adjusted by the mover screw (16) and after adjustment the play is taken up by the grooved screw on the mixing chamber cover.

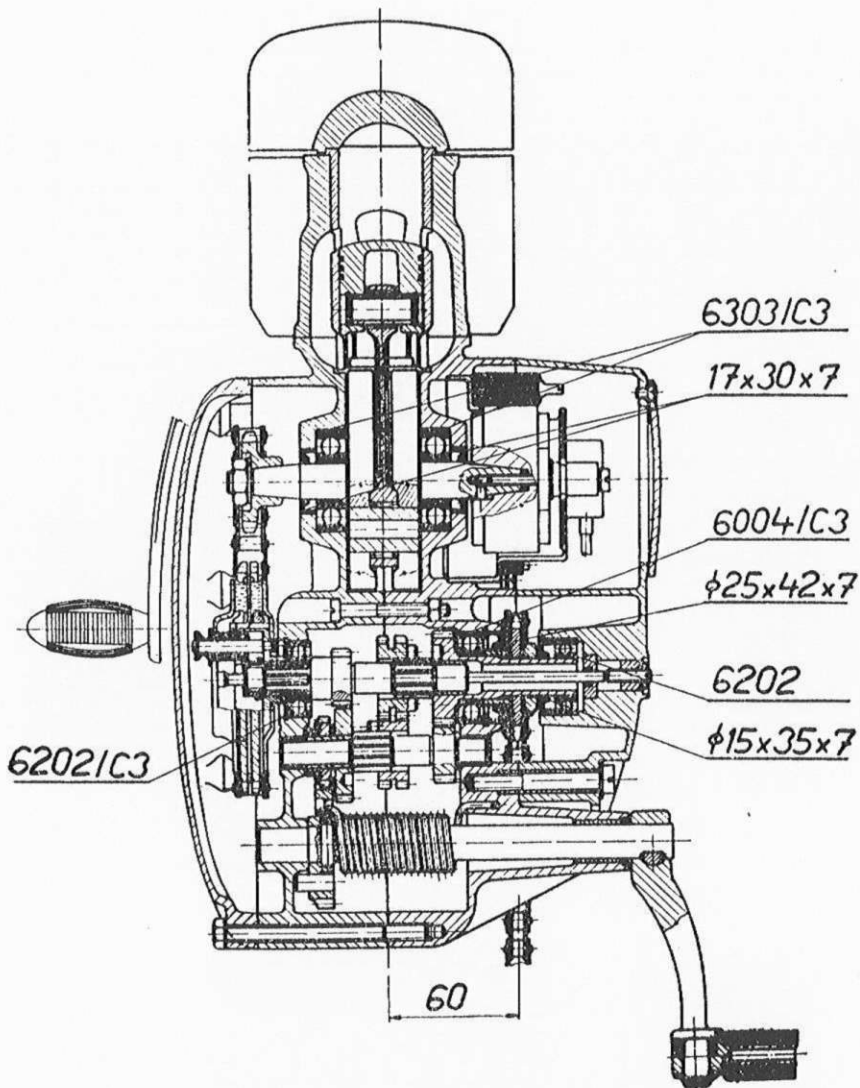

Fig. 16 — Jawa 50, types 20 and 21

## IV. ENGINE

### A. DISASSEMBLY AND ASSEMBLY WITHOUT REMOVING THE ENGINE FROM THE FRAME

#### 25. Dismantling the head and cylinder

Dismantle the protective front shield, the tunnel and the front cowl (chapter 11). Unscrew two nuts fastening the exhaust which is to be removed from the studs downward and two nuts of the carburetter intake socket and remove the carburetter. Unscrew four nuts of the cylinder head and remove them together with washers by means of socket spanner no. 10 (fig. 17). If the cylinder head cannot be removed easily, loosen it by knocking with wooden hammer or by opening with two screwdrivers. By treading upon be removed (fig. 18). After dismantling the cylinder cover the hole in the engine box beneath the piston with a rag and proceed to effect the removal of carbon deposit.

#### 26. Change of piston rings

The disassembly is effected as mentioned in the chapter no. 25. Remove the rings with help of three iron sheet bands. Introduce one band into the middle and two bands. Introduce one band into the middle and two bands to the piston ring ends and remove then successively the rings. The change can be effected also by extending the rings with fingers. Take care, however,

Fig. 17

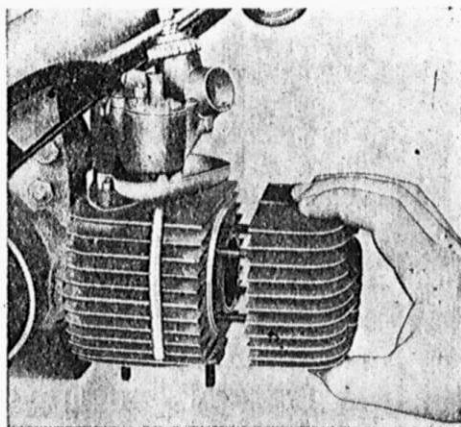
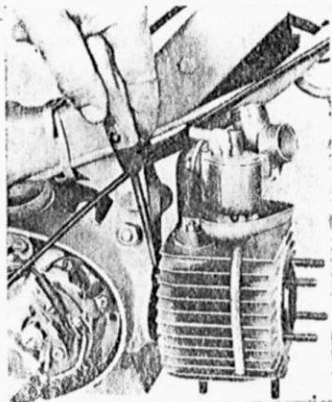

Fig. 18



to avoid their breakage when extending the ring. Change the rings if the space in the lock is bigger than 0.8 mm. The correct space with amounts space in the lock is bigger than 0.8 mm or 0.031 in. The correct space with amounts 0.2 mm or 0.007 in. The space amount is ascertained if the removed ring is inserted in the cylinder upper part and the space is measured with help of feelers. The assembly of new piston ring is effected by careful extending of the rings.

### 27. Disassembly and assembly of piston (fig. no. 34)

Remove the head, the cylinder and the piston rings. With help of flat pliers remove 2 lock rings (12) locking the piston pin (11). With M 10 puller pull the piston pin (11) from the piston (9).

Proceed in the following way while assembly:

Heat up the piston with hot water to 80°C and with help of M 10 puller put on the pin. The pin is to be locked by safety both sides.

### 28. Dismantling the cylinder and the head

Clean the contact surface of cylinder on the engine box and the packing moistured in the oil is to be slid onto the studs. Move the piston by depressing the start lever to the upper dead center. Oil the rings on the piston, set them to the correct position as compared with safety pin in the piston groove compress the rings and slide on the cylinder. Lubricate inside the cylinder before to put it on. Remove the socket after putting the cylinder onto the piston. Take care that after sliding the head onto the studs the washers are placed under every nut with which the head and the cylinder are tightened to the engine box. The head nut is tightened so that the head contracts uniformly the whole circumference of cylinder. Clean thoroughly, dry and oil gently the cylinder surface while assembly of cylinder head.

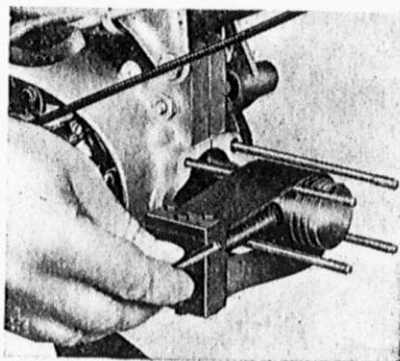

Fig. 19

Neither the packing nor the sealing putty is to be put beneath the cylinder head. The packing is ensured with two recesses (labyrinths) on the cylinder liner.

## 29. Disassembly and assembly of starting and shifting levers \*

Unscrew the M8-nut with spanner no. 14 in the upper R. H. engine part and remove the lever (16) from the hole. Disconnect the gear shifting pull rod from the automatic and remove the shifting lever. Remove the starting lever after unscrewing the M6-nut, pull the starting lever wedge and remove the lever from the starting shaft. Proceed vice versa when assembly of both levers.

### 29a. Dismantling the R. H. cover

3 fastening screws are removed from the cover. Disconnect the cable from the clutch disengaging finger and remove the cover. Dismantle the disengaging finger by knocking it on the cover outer side and remove the finger. Dismantle the bearing after removing the sealing ring "gufero" and heating the cover. While changing the sealing O-ring of the disengaging bar, dismantle the bearing and gufero sealing ring from the cover; remove the ring out of groove by means of screwdriver.

## 30. Disassembly and assembly of secondary chain wheel

Dismantle the R. H. engine cover and disconnect the secondary transmission chain. Straighten the safety under the nut with M 15 straightener and with # 19 spanner unscrew the nut, remove the secondary wheel.

Fig. 20

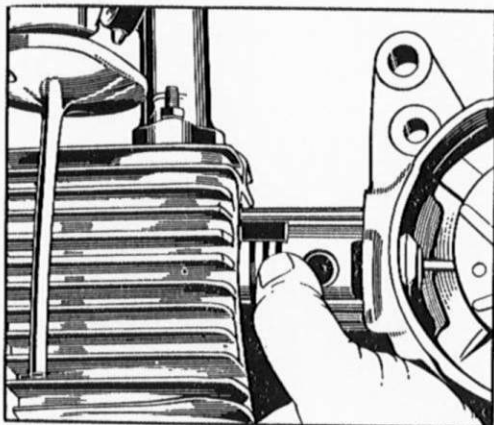

### 31. Advanced ignition adjustment

Remove the cylinder head. Rotate the crankshaft (1-fig. 22) till the piston reaches TDC (the piston is in its highest position). In this position set the contact breaker point gap (3) to approx. 0.4 mm or 0.015 in. (16 THOU) having slackened the screw (2). When the gap has been set, tighten the regulating screw (2). Insert a cigarette paper between the contacts (3) and rotate slowly the crankshaft in the opposite direction of the engine rotation till the paper passes through the gap. This will occur when the gap between the points is sufficient for the paper be removed (approx. 0.05 mm or 0.001 in. — 2 THOU). Piston should be at this instant 1.2 — 1.5 mm before the top dead centre. Measure this distance with bar or depth gauge. Should the advance not be correct, loosen the magneto clamps (4) and rotate the whole magneto. Repeat then the whole adjustment process till all values are correct. Do not forget to tighten the clamps after the correct adjustment was obtained. Having tightened the screws, check the advance and the point gap. The interrupter fastening bolts, are secured by the varnish.

Fig. 21

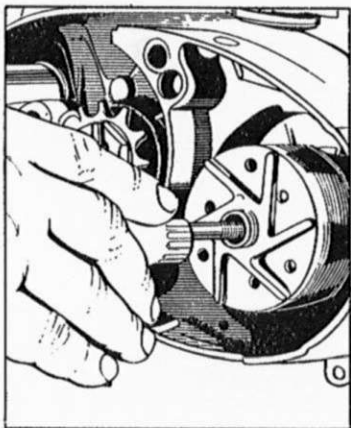
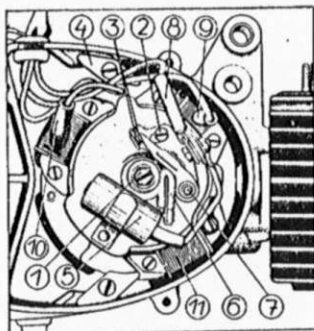

Fig. 22



### 32. Magneto disassembly and assembly (fig. 21)

Remove the R. H. cover, disconnect the cables from the terminal block as well the contact breaker cable. Unscrew two screws fastening with help of clamps the stator to the engine box halves. Remove the stator. Unscrew the screw fastening the cam and rotor to the crank mechanism pin and detach the cam. Screw the M 8 puller (fig. 21) or the long M8 screw into the hole in the rotor. Detach the rotor from the crank pin by rotating the puller and pull the pin from the crank mechanism.

When assembly insert the pin into the crank mechanism hole and fasten the cam. Afterwards screw on the stator, connect the cables and adjust the advanced ignition and contact distance.

Changing the pin which determines the rotor position, be carefull, not to use a high one. The high pin would cause the absence of rotor contact with self-locking cone what would result in the rotor untrue run.

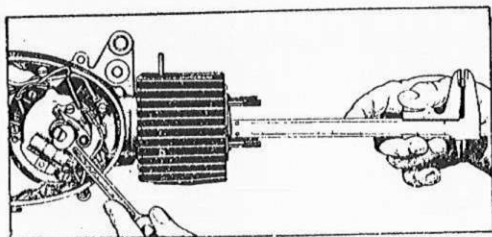

Fig. 23



### 33. Dismantling the primary transmission and the clutch (fig. 24)

Detach the front cowl. Unscrew the M8 nut fastening the shift lever to the engine with # 14 socket spanner and remove the lever. Dismantle the L. H. floor. With help of spanner unscrew the discharge hole screw in the engine lower part and drain the oil from the engine. Unscrew all cover fastening screws on the L. H. engine side and with spanner no. 10 unscrew the bolt in its rear part. Should the cover not be able to be detached after unscrewing the screws and the bolt, loosen it by a slight knocking with wooden hammer. Remove the safety pins (8) with a screwdriver (fig. no. 24).

After releasing circlips remove the clutch pressure plate (3) together with cups (6), springs (5) and washers (7). By means of washer straightener M 15 straighten the washer (9) under the nut (10) of the fixed plate (2). With pipe wrench no. 14 unscrew the nut. (10) (fig. 26) and with no. 19 spanner unscrew the nut of the primary wheel. With help of N 9 puller loosen the chain wheel (14) from the crankshaft (fig. 27). The primary wheel, chain and both cork plates (1) and driven plate are to be removed jointly.

Fig. 24

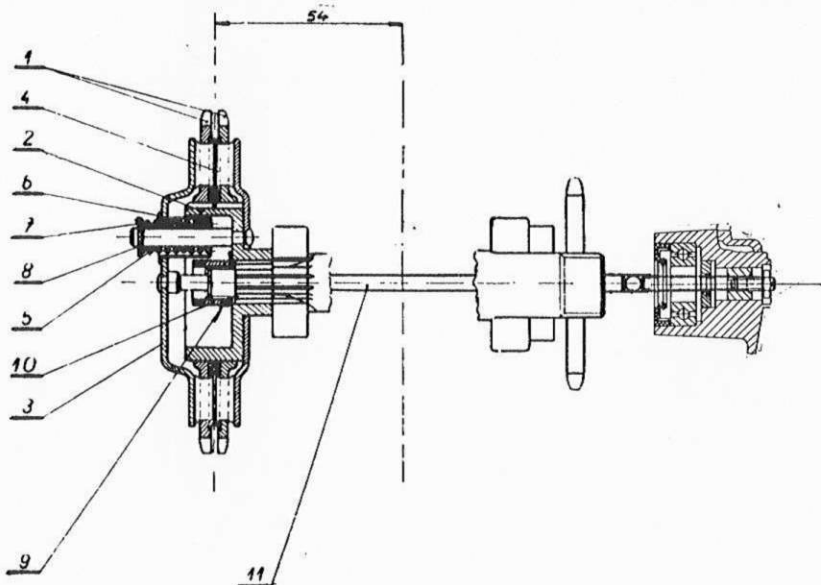

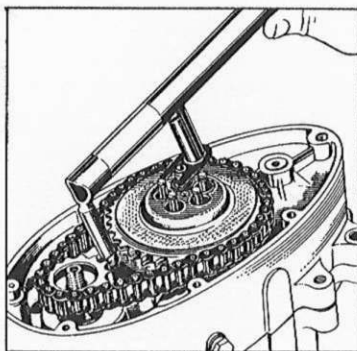

Fig. 25

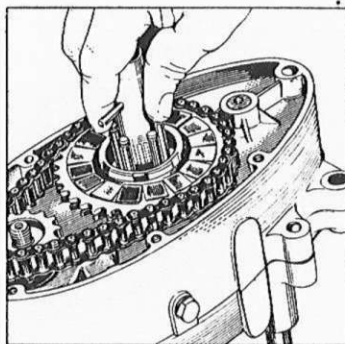

Fig. 26

When changing the cork lining or chain, dismantle always the whole primary transmission together with clutch. Proceed vice versa when assembly of primary transmission and clutch. Take care, however, to use the former washers under the nuts. After assembly lock the nut (10) by bending the washer edge (9) to prevent it thus from to be loosened. Oil the cover contact surface and stick then the paper packing.

#### 34. Change of the cork inserts

Put the cork inserts into the boiling water till they soften. Press the inserts into the plate till these project uniformly on both sides and make them dry. Cut the dried inserts with a sharp knife and grind them on the emery paper to make overlap the inserts uniformly on both sides. The ground plate thickness shall amount 5.5—0.2 mm or 0.216—0.007 in.

#### 35. Change of sealing rings (Gufero) (fig. 31)

When changing the sealing rings (Gufero) (29) on the crank mechanism L. H. side, dismantle the whole primary transmission (chapter 33). Pull the sealing ring (29) also on the opposite side of crankshaft, having dismantled previously the magneto. Pull the sealing ring (30) of secondary transmission after having dismantled the secondary chain wheel (chapter 30). Mount the new sealing rings by bumping them with a wooden hammer or press them. When bumping the sealing ring, take care, to prevent the spring from to be fallen onto the ring. Before mounting the sealing rings, deep them in the engine oil to be more elastic.

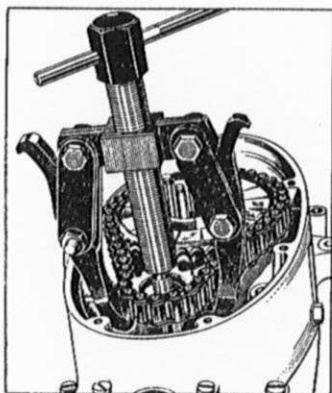

Fig. 27

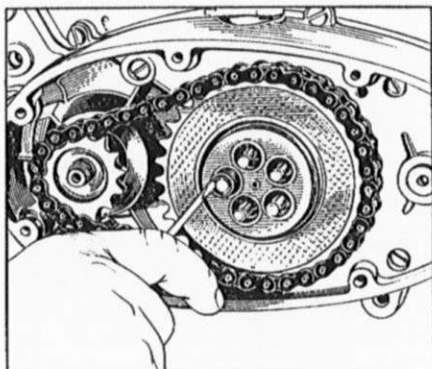

Fig. 28

### 36. Dismantling the exhaust silencer and carbon deposit removal (fig. 29)

Unscrew the M6-nut (9) with a pipe wrench no. 10 and detach the tail pipe (4). Remove the end (7) and the partition (7-3). Should the partition be too much covered with carbon and not able to be removed easily from the exhaust body (3), use a steel wire piece abt. 300 mm or 11.8 in. long and introduce its bent end into one of two partition holes. Take the opposed wire end in the pliers and detach the partition by pulling it. Detach then the exhaust body from the machine. Clean the dismantled parts with a steel wire brush and clean also with help of steel pointed object the end cone holes in the space of the terminal seating. Should a heavy carbon deposit be in question, the not chrome-plated parts are allowed to be burnt. (Caution, the risk of fire is running!)

Clean with pointed object the holes of partition, being welded in the exhaust body space, the diffuser annular ring and the rectangular needle holes. The carbon deposit removal is to be carried out in the terms as per maintenance table.

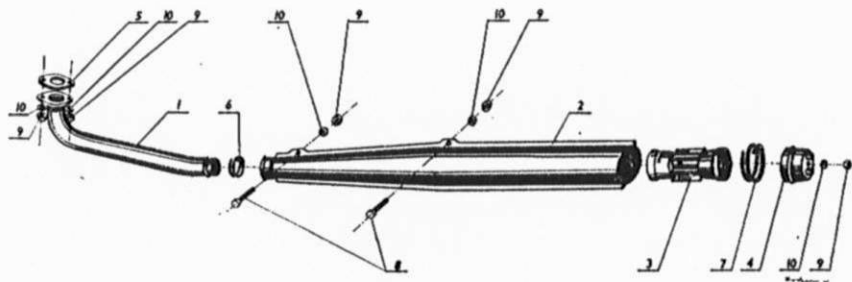

Fig. 29

## B. DISASSEMBLY AND ASSEMBLY AS TO REMOVE THE ENGINE FROM THE FRAME

### 37. Dismantling the engine from the frame

Remove the cowls (chapter 11), disconnect the fuel supply, gas and clutch cables and shift lever pull rod. Disconnect the secondary chain and with no. 14 pipe wrench unscrew four fastening M8 screws and detach the engine from the frame. Any assembly and disassembly work as per chapter IV A, is able to be carried out with engine dismantled.

### 38. Dismantling the engine box (fig. 31)

When repair of gear box, crank mechanism, change of bearings, respectively the shift mechanism, the engine case is to be dismantled. Carry out the disassembly in the following way: Detach the cylinder head, the cylinder, L. H. cover (8) and the primary transmission with clutch. Dismount also the magdynamo when repair of crank mechanism. Pull the centring bushes (24) with M 13 puller. Unscrew 9 screws (17, 18, 19) fixing the engine box and unscrew the stop screw of the automatic. Detach the box with M 1 separator M 13.

Put on the M 1 separator from the engine box L. H. side. The M1 separator screw rest against the crankshaft pin and countershaft. Make sure whether the separator is thoroughly fixed at the proper position, and then

Fig. 30

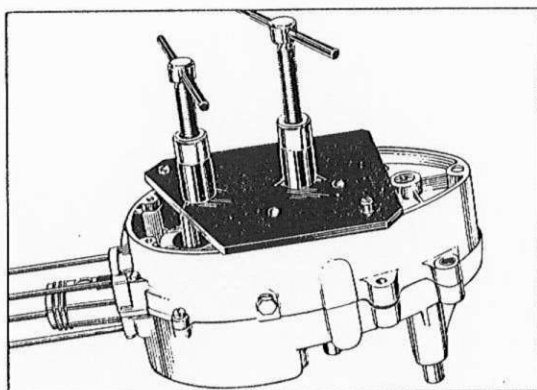

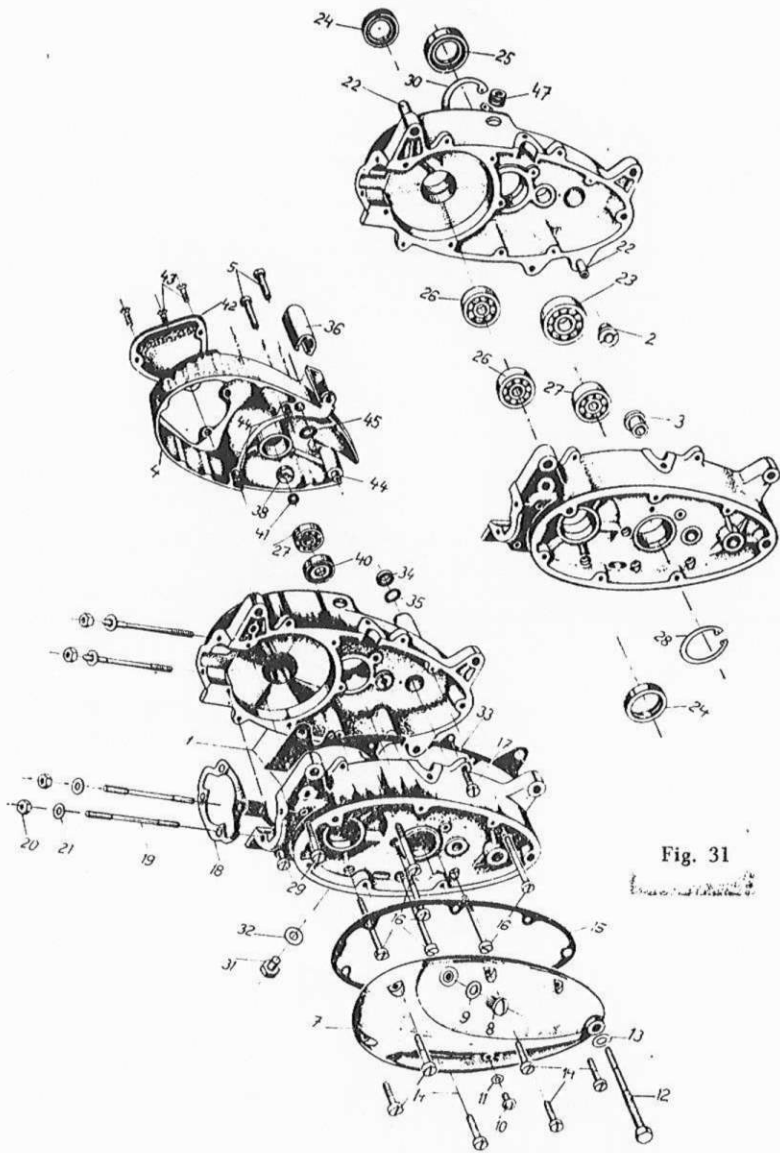

Fig. 31

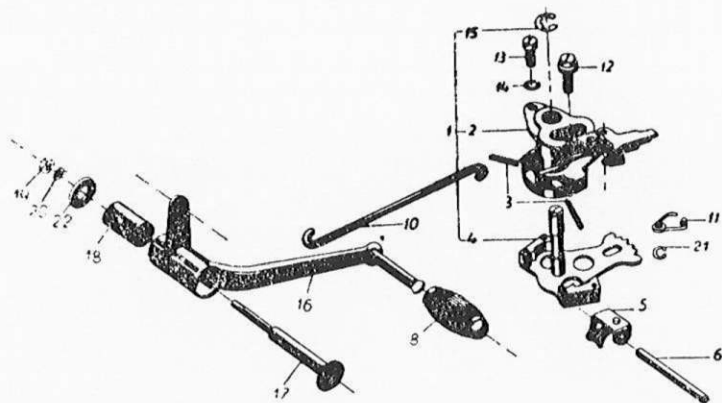

Fig. 32

only rotate alternately the screws, dismantling thus the engine box.

Check whether the box is dismantled uniformly. Should the box be crossed, straighten it with a slight knocking by a wooden hammer at the location where is a smaller interstice between the box halves.

### 39. Dismantling the gear box (fig. nos. 32, 33)

Pull out the guide (6, fig. 32) of the shift fork (5). Pull out the main shaft (1, fig. 33), the gear, 20 teeth (4), the shift fork, the countershaft (2) together with a pinion (3) and the gear, 18 teeth (14). Detach the return spring (15) of the start shaft (12) from the catch in the R. H. box half and disengage the start with segment (13). From the upper part of the R. H. box half unscrew the M6×18 screw (13, fig. 32) fixing the gear shift automatic (1) with R. H. box half and remove the automatic. Dismantle the secondary transmission gear and pull out the gear with hub (5, fig. 35) by knocking with a wooden hammer.

### 40. Dismantling the crank mechanism from the box

Before dismantling the crank mechanism from the box, remove first of all the shift lever (chapter 29). Dismantle the magneto (chapter 32), the primary

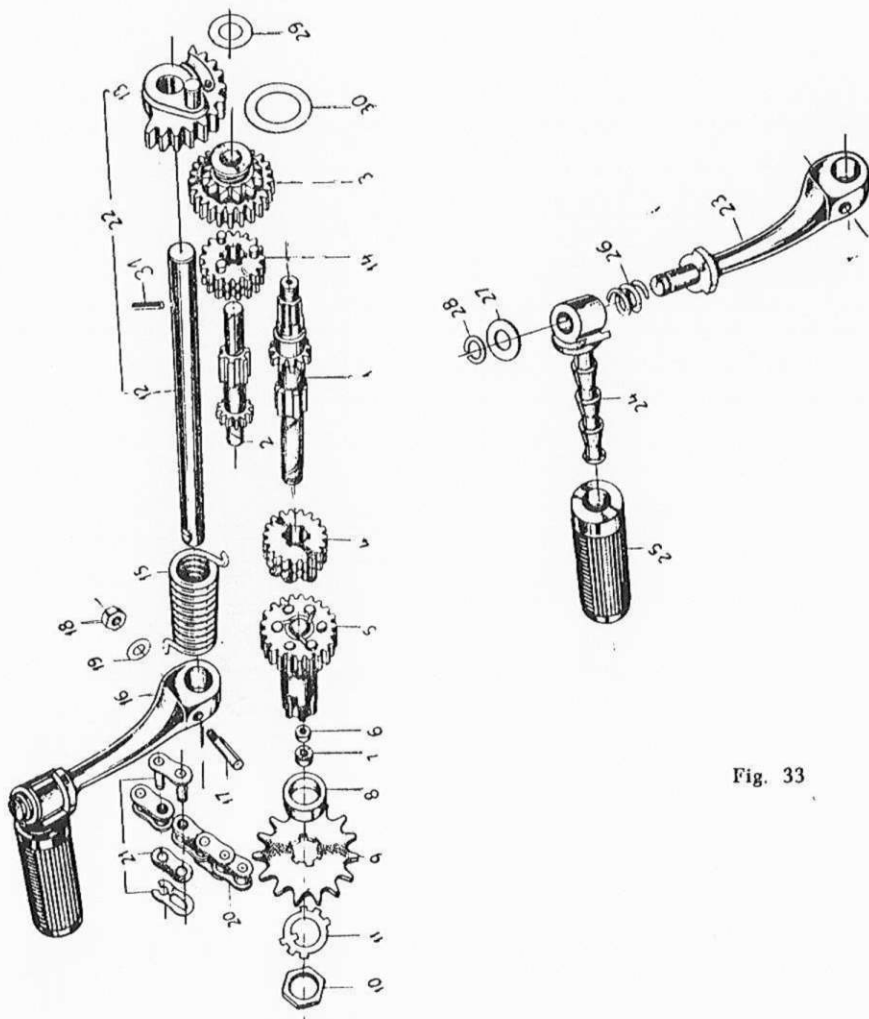

Fig. 33

transmission with clutch (chapter 33), the head with cylinder (chapter 28), separate the engine box halves (chapter 38) and dismount the gearbox (chapter 39).

Crank mechanism from R. H. box half dismount under the presser.

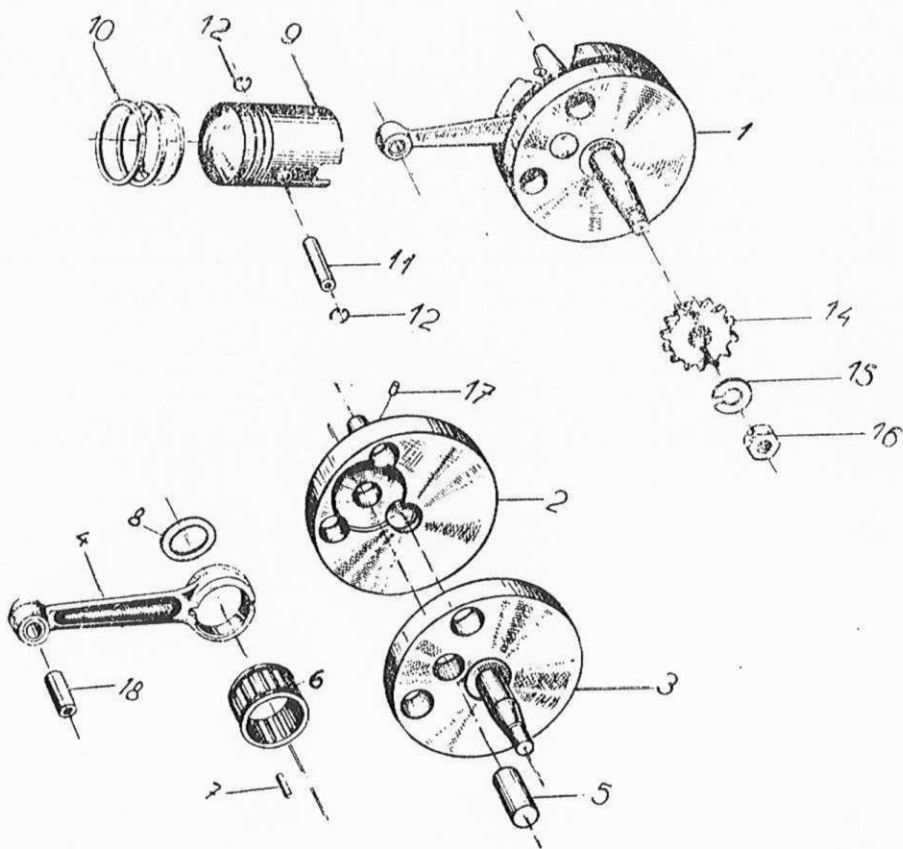

Fig. 34



41. Repair (disassembly) and centring the crank mechanism (fig. nos. 34, 35)

Having dismantled the crank mechanism from the engine box, dismount the crankshaft pin (5) from both crankshaft halves by pressing it out and change the faulty pieces. When assembly of crankpin bearing pair the needles (7), the crank pin (5) and the connecting rod (4) in accordance with grading table. Introduce the cage (6) into the connecting rod and arrange

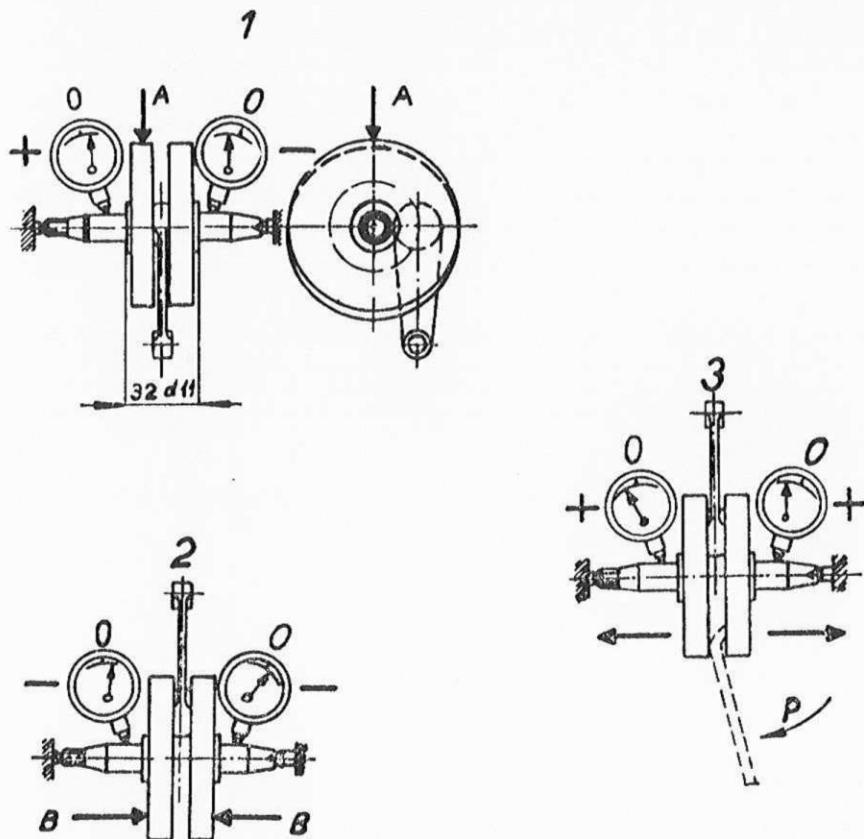

Fig. 35

it jointly onto the crank pin which is then pressed onto the R. H. flywheel. Insert the needles (7) into the cage and carry out the pressing of the crank mechanism. On pressing the crankshaft with help of angle straighten the R. H. (2) and L. H. (3) halves of the crankshaft so as to keep the approximate alignment of both crankshaft parts. Having pressed-in the shaft, center it in the following way (fig. 35):

The permissible eccentricity of the crankshaft pins amounts  $\pm 0.01$  mm or 0.003 in. The permissible deviation of the shaft pin eccentricity as compared with flywheel amounts  $\pm 0.02$  mm or 0.007 in. The axial tolerance of the flywheel shall be within the tolerance of d 11.

Straighten the crankshaft pins according to the plane passing through the connecting rod pin axis (the pointers of both dial indicators must show the deviation of the same direction either (+ +) or (- -).

#### Working procedure:

If the dial indicator pointers show (+ -):

- a) ascertain the highest point of the crankshaft pin,
- b) knock with wooden hammer using the adequate force onto (+) the crank arm in the given direction (arrow A).

Center the crankshaft pins passing through the connecting rod pin (the value of dial indicator pointers deviation is fixed at the place against the connecting rod pin).

Should the pointers show (+) the crank arms are to be pulled off in the given direction with help of lever.

Should the pointers show (-) knock onto the crank arms laterally in accordance with "B" arrow in the given direction.

Should the centring (+ -) be in plane passing through the connecting rod pin axis and the crankshaft pins, the centring of the crank mechanism is impossible, since the distances of the connecting rod pin and the crankshaft pins are different in the crank arms. In this case the crankshaft is to be built in without prescribed centring, however, with max. deviation of 0.02 mm, the crankshaft, anyhow, must be exchangeable.

#### 42. Pressing out the bearings from the engine box

Carry out the complete disassembly of the gearbox (chapter 39) and wash the box. Remove the sealing rings and using the pliers remove the lock rings. For better disassembly of bearings carry out the heating of the box to 80 °C.

#### 43. Change of the bushes (fig. 31)

The countershaft is fitted in two bronze bushings (2,3) which are pulled from the box with help of object having the outer diameter as the bush. The bushes are changed in such a case only if they are damaged or too worn.

Having pressed new bushes turn their holes to  $\varnothing 11 \begin{matrix} + 0.027 \text{ mm} \\ - 0.000 \text{ mm} \end{matrix}$ .

#### 44. Assembly of engine (working procedure)

Before assembly of engine wash thoroughly all its parts and dry them out. Clean the cover and engine box contacts surfaces by scraping them carefully. Revise thoroughly all the parts and change the damaged or worn ones. Use allways the original parts supplied by the manufacturer. Should one of the engine halves be damaged, both halves are to be changed since these are paired in the making Works. Oil all the moving parts, pins, shafts, gears etc. when assembly. Before the assembly arrange the individual parts on the assembly bench on the clean paper.

#### 45. Assembly of bearings and lock rings

Before the assembly of bearings in both engine box halves are pressed the bushes only. Insert the lock rings into both engine box halves. Heat the engine box to abt. 70—80 °C. Having heated the boxes mount the respective bearings into the holes till they contact the lock rings. Take care to avoid the oblique fitting of bearings. Should the bearings be fitted obliquely, they would damage the hole edges and their seating in the hole would be oblique.

Fig. 36

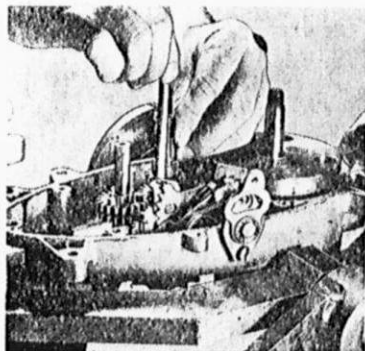
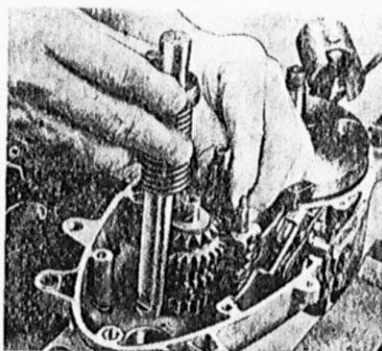

Fig. 37



#### 46. Assembly of the crank mechanism

Mount the crankshaft into the heated box half. Mount the gear box (chapter 47). Oil the contact surfaces of the R. H. box half, stick the paper packing and put on the L. H. box half.

#### 47. Assembly of the gear box (fig. 32, 33, 36, 37)

Carry out the assembly after fitting the crankshaft and the gear with hub (5). Slide in the gear shift automatic (1) introducing at the same time its rear part into the groove in the box boss and fasten it with screw (13). To make easier the assembly of the gear box shift on the automatic the neutral position between the 1-st and 3-d gears.

Mount the starter shaft with segment (22) and reversing spring (15) the end of which is to be fitted in the engine box. Mount the start lever (16) on the shaft end and lock it with the wedge (17). Introduce the countershaft (2) into the R. H. bush so as to make engage the third gear teeth. Mount the second gear (14) onto the countershaft so as to make point three pins to the left. Mount the gear shift fork (5) into the oval automatic hole; the fork is to be fitted in the second gear groove. Mount the guide (6) (fig. no. 36) into the steering fork so as to make point its narrowed end to the left. Mount the first gear (4) onto the fork so as to make point three pins to the right.

Mount the main shaft (1) into the slotted holes of 2-d and 3-d gears. Mount the first gear (fig. 37) onto the countershaft on which also the starter gear is fitted. To take up correctly the axial play of the countershaft, mount on the starter gear a thin spacing washer (29). Having fitted the gears into the box R. H. half verify the gear shift function by shifting the individual gears.

#### 48. Assembly of the box halves (fig. 31)

Oil the R. H. box half contact surface and stick onto it the paper packing (37). By compressing the start level forward introduce the segment teeth into the starter gear. Depress the start lever till the contact of the engine box halves is obtained. Arrange the centring bush in the front and rear box parts and tighten then the box halves with nine screws (17, 18, 19) and insert the stop screw (12, fig. 32) of the automatic.

Mount, further on, the sealing rings on both sides of the crank mechanism and on the secondary gear shaft (chapter 35).

#### 49. Assembly of other parts of engine

The other parts of engine as the cylinder, head, the primary transmission with clutch etc. are to be mounted so as per the chapters of IV A-section. Pour 0.5 lit. oil into the assembled engine as per the lubrication table and mount the engine into the frame.

## V. ELECTRICAL EQUIPMENT

### 50. Electric energy source and electrical equipment connection

The electric energy source is the two circuits ferrite magneto-A. C. generator of 6 V rated voltage. The voltage characteristic under load of two 6 V/25 W and 6V/5W lamps in dependence upon the r. p. m. is shown in the fig. no. 39. The cables are coloured and marked according to the wiring diagram.

Check also the cables for wear when repairing the machine. Thus the short circuit would be avoided. Wrap the cables showing the damaged insulation with insulating tape, respectively change them. Retighten the connections and secure with varnish. Check the soldered connections. Clear the causes of damaged insulation (sharp edges, free cable etc.).

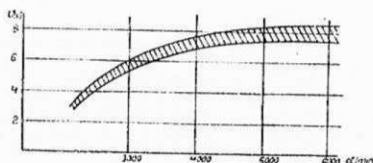

Fig. 38 — Jawa 50, types 20 and 21

Fig. 38 — Dependence of voltage upon the magneto r. p. m. Load with bulbs 5 + 25 W.

### 51. Ferrite magdynamo

The magneto rotor is formed by 2-pole shoes which due to their star-like arrangement form the 6-poles system excited by the ferrite ring being fixed in the not magnetic filling. Its taper part is lead to the crankshaft and fixed with M5-screw. The position of the cam is given by the securing groove.

The generator stator is fixed on the box and may be rotated within the limits of 20° to adjust the advanced ignition. The generator stator forms a stator carrier being of not magnetic material and carries the fixed and moving contact breaker arms, the cam scraper, the condenser and the poles feeding the electric appliances.

The ignition pole has the winding of  $\varnothing$  0.60 Cu-wire and number of turns

is 160. The end of the ignition winding pole is connected to the condenser.

The lighting pole fed by the headlamp 6V/25W has the winding of  $\varnothing$  0.71 Cu-wire and number of turns is 140. The winding end is soldered to the connector. The pole for lighting the number plate has the winding of  $\varnothing$  0.40 Cu-wire and number of turns is 420. The winding end is also soldered to the connector.

The pole shoes are fixed by M4 screws to the stator carrier. While repairing or changing the pole shoes the assembly is to be carried out so as to have the interstice between the rotor and pole shoes amounting max. 0.3 mm. The magneto does not require any maintenance. Revise from time to time the magneto, clean and check the contact breaker as well the advanced ignition. Lubricate the contact breaker pin as well the cam scraper. The magneto may fail due to mechanical damaging. When such a defect the damaged parts are to be changed.

## 52. Ignition

### Ignition coil

The coil does not require any maintenance. It suffices to keep it clean, to fix it and to connect the cables. It is impossible to start the engine with faulty coil, this stops suddenly — the ignition stops to work. The coil defect appears as an irregular sparking on the plug or as a fainted bluish sparking. The faulty coil (the burnt primary or secondary series windings) must be changed. When change, use the 8V coils, bearing the manufacture marking 02-9210.34 only, these are especially intended for the A. C. generator ignition system. The cable for the plug has no interference suppression device terminal, if the PAL 14-8 plug is used. The ignition defects may be ascertained by means of the test lamps. On applying the test lamp point onto the cable, the test lamp has to flicker. The test lamp flickers, however, regardless whether the plug is good or wrong.

### Sparking plug

Used is the PAL 14-8 spark plug having the interference suppression resistance in its body. Should another plug type without interference suppression resistance be used, use then the cable shoe with interference suppression resistance.

The spark plugs are to be kept clean, especially the external insulator part. The distance of the electrodes shall amount 0.4—0.5 mm or 0.015—0.019 in. This is achieved by bending the external electrode. Check the correctness of the choice of the plug thermal value.

The most ignition failures are caused by the plugs:

a) the low thermal value plug — the electrodes are brought to the heat and the engine has the detonations (the piston is knocking).

b) The high thermal value plug — this becomes often fouled, sooty and oiled.

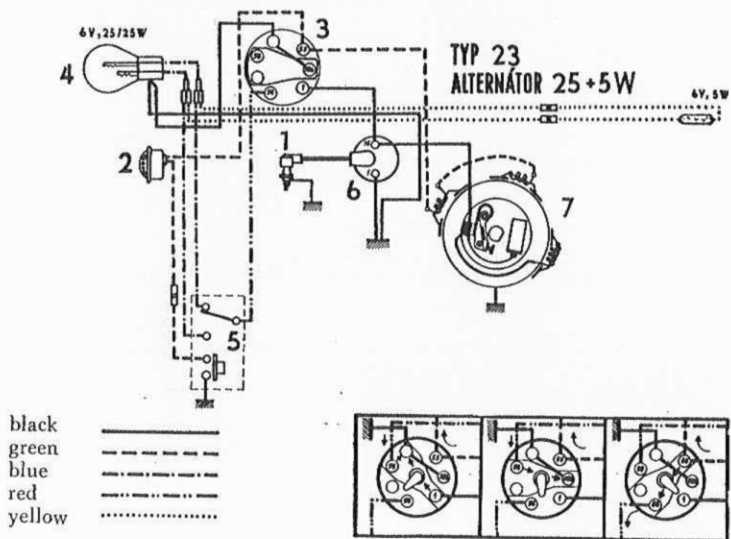

39. Electric wiring diagram

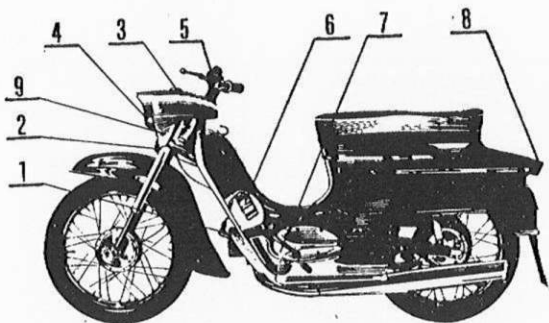

Fig. 40 — Electric current sources and appliances.

1. Sparking plug — 2. Buzzer — 3. Switch of the lamps and ignition — 4. Headlamp — 5. Dipswitch of the lights and push button of buzzer — 6. Ignition coil — 7. Magneto.

c) The oiled plug causes the miss-ignition of the engine — the spark is irregular, the engine is not able to be started or it stops during the drive. The cause of oiling or carbonizing the plug is usually the incorrectly adjusted carburettor or improperly chosen thermal value of plug. Clean resp. sand blast throughly the fouled plugs.

d) The similar failures occur in case of bigger distance of electrodes as with the oiled plug.

e) The engine is not able to be started with short circuited electrodes or with injured insulation. It stops during the drive if these failures occur.

### Contact breaker

The contact breaker surfaces shall be straight and clean. The burnt or fouled contacts are cleaned with petrol and the protuberances are carefully removed with a fine file or sharp knife. Too worn contacts are to be changed. The engine fails with fouled or burnt breaker contacts, the spark is irregular, it stops respectively and is not able to be started.

The contact breaker arm must move freely on the pin, the leaf spring must have a good contact with feeding screw. The felt must be sufficiently impregnated with grease to avoid the seizing of cam against the contact breaker finger which is of texgumoid, novotex etc. to avoid thus the diminishing of the distance between the contacts. When ignition failure in the contact breaker check whether the contact breaker arm is deflected by the prescribed play, whether the contacts are straight and clean, whether they



are not loosened or oiled, whether the cam is fitted eccentrically and not causing two break distances, whether the contact breaker arm is not broken or weakened, whether the contact breaker arm does not stick on the rotating pin and whether it is sufficiently lubricated. The latter failures cause the engine to fail, especially at high r. p. m. Should the water get into the contact breaker (the ignition does not work), blow-out the water, wipe it out carefully and allow it to dry off.

### Condenser

The faulty condenser causes the ignition does not work at all. The discharged condenser or the condenser with surface short circuit causes the engine stoppage while drive — the plug does not give any spark. The failure is ascertained by disconnecting and by rotating the engine — between the breaker contacts jumps the spark. The occasional damaging of condenser insulation appears as an irregular ignition and strong sparking on the contacts. The condenser outlets are sometimes torn due to vibrations or they are wrongly connected. Having interrupted the condenser outlet the breaker contacts are sometimes burnt due to a strong sparking and the ignition failure takes place. Check the condenser outlets, and when short circuit and fouled condenser, clean the face insulation wall from the fouling. Should an external failure be discovered and the contact having been cleaned still remains faulty, change it.

### 53. Lighting and sound signalisation

The headlamp has the 110 mm diameter and bears the twin-filament 6 V 25/25 W bulb. The light incidence upon the roadway be adjusted by the inclination of parabola, having loosened previously the set screw on the headlamp top by pushing the screw forward and backward or retightening it. The way how to take out the bulb from the socket is to push it and rotate it to the left till it is pushed out under action of spring. The tail light has the 6 V — 5 W tubular lamp.

The buzzer is connected to the magneto light clamp no. 55 (on the switch of lights). The opposed buzzer contact is connected to the frame through the control push button. The signal loudness may be arranged by the screw in the center of buzzer on its front side. The fineness and loudness of the signal are adjusted by loosening the nut and rotating the screw.

## VI. FAILURES AND THEIR CLEARING

### 54. Small engine output

a) Wrongly adjusted advanced ignition.

For properly adjusted advanced ignition (see chapter 31).

b) False air suction.

Remove the packing under suction branch or tighten the suction branch.

False air suction may be cleared also by changing the packing through the sealing ring under magneto.

c) Oil suction in the box appears as a strong fuming, the ignition plug is oiled all the time. This failure is caused by the oil suction through the sealing ring in the L. H. box half. The failures are cleared by changing the sealing rings.

d) The engine runs hot.

The failure is caused by the clogged exhaust silencer — carbonisation. The remedy is done by cleaning the exhaust silencer (chapter 36).

e) The engine knocks — it reaches difficultly the higher r. p. m. — it fails. The failure is caused by wrongly adjusted carburetter, clogged jet or choked cleaning insert of intake silencer. This is cleared by cleaning and adjusting the carburetter and insert.

f) Decreased machine output — decreased compression. This failure is caused by the worn cylinder, piston rings. This is cleared by changing the new piston rings or by the re-bore. See the table of re-bores.

g) Blowing-off the cylinder head.

This is cleared by tightening the head.

h) Braking the machine on the wheels.

The failure is caused by the brake lining, seizing against the brake drum.

This is cleared by re-grinding the lining and correct adjustment of brakes.

### 55. Seizing and whistling in the engine

The gearbox is noisy. This failure is caused by:

a) Little or no oil in the gearbox. Replenish it.

b) Worn out crank mechanism bearings or another gearbox bearing — the engine rustles and whistles.

This is cleared by changing the respective bearing.

c) Not lubricated cam scraper. The engine is whistling.

This is cleared by imbibing the felt scraper lining with oil or grease.

d) The rotor seizes against the stator.

This is eliminated by cleaning the cone in rotor and on the crank pin. Tighten properly the rotor.

e) The primary chain seizes against the box, it is free. Change the chain.

## 56. The engine knocks

- a) Free piston pin (sharp knocking). Change the piston pin.
- b) Worn out crankpin bearing. Change or repair the crank mechanism (chapter 41).

This is cleared by adjusting the advanced ignition to the prescribed value.  
c) Too much carbon in the cylinder head and on the piston. Carry out the decarbonisation.

- d) Too much carbon in the cylinder exhaust port.

Dismount the exhaust and remove the carbon deposit of the exhaust port.

## 57. Carburettor failures

The most frequent carburettor failure is usually the fouling of the fuel intake holes. The clogging may be avoided by the occasional change of screen

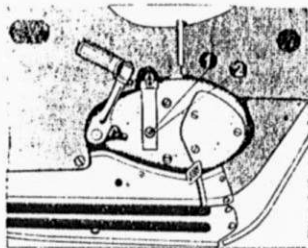

Fig. 41

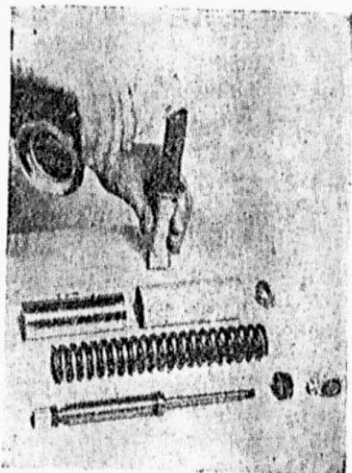

Fig. 42

on the petrol cock. In case of fouling the jets, these are to be screwed out and blown through (avoid the cleaning with hard objects).

The further carburetter failures are usually:

- a) seized mover (regrind it with help of lapping paste),
- b) loosened mover knocks (change it by new one),
- c) bent mover needle (change it by new one),
- d) broken float (change or solder it after drying-off),
- e) the float needle leakage (change the needle or grind it with lapping paste).

#### 58. Gear shift failures

a) deformed link of automatic due to forced shifting — the defect causes the gear shift failure.

b) Jamming the catch on the body of automatic — the defect causes the gear shift failure — this is cleared by cleaning the catch seating — the catches have to rotate freely.

c) Jumping out the 1-st or 3-d gears — the failure may be caused by rotating the gear shift automatic, due to faulty workmanship of the cylindrical bosses on the 20-teeth gear. The edges of the engaging gear holes with hub are heavily worn. The rotating of the automatic is caused either by the interference of groove in the box in which the automatic engages or the automatic may be deformed. Check all mentioned failures when dismantling the gearbox. Change the gears showing excessive wear of edges and engaging holes.

d) Knocking in the gearbox in the neutral position. This failure may be caused by the bent gear shift fork, free pin or bent link of the automatic. Clear it by straightening the link of automatic or by changing the faulty parts.

e) The start lever is idle when starting — no engaging. The failure consists in the ratchet wheel which remains to hang in the disengaged position. This is cleared by dismantling and finishing the bush.

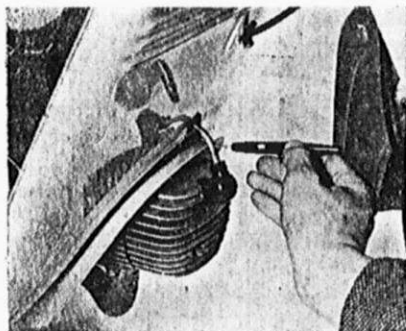

Fig. 43

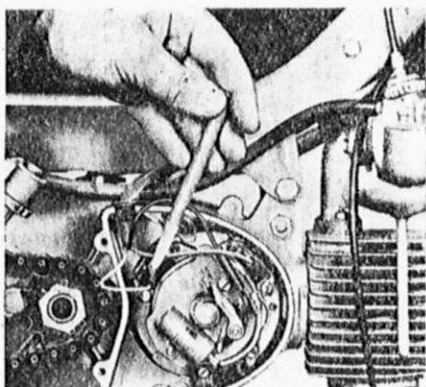

Fig. 44

f) The start lever jams.

The failure is caused by the start segment. The start segment teeth are torn. Clear it by changing the segment.

### 59. Defects of clutch and its adjustment

The clutch slips:

The defect is cleared by adjusting the set screw; should the clutch slip even if being adjusted properly (this may be checked on the disengaging lever on the handlebars which must show a play) stop to clear the defect by further diminishing the play. Revise the cork lining, whether the cork insert is not fallen out or whether the lining is not worn. This is to be cleared by changing the cork lining.

The fatigued springs of the pressure plate cause the clutch to slip, the slip is cleared by introducing the washers under the springs or by changing them.

The clutch does not disengage

The defect is caused by the seized disengaging rod. Change the rod, taking care, however, to lubricate from time to time, the disengaging rod and the balls. The clutch adjustment is carried out in the following way (fig. nos. 46, 46a):

1. Loosen the nut (2) and take up the respective play with the screw (1) arranged in the center of R. H. engine cover side. Having done it retighten the nut.

2. While pulling out the clutch cable take up the play by loosening the lock nut of the set screw (4) on the lower part of the R. H. engine cover side and the play is adjusted by unscrewing the set screw (3). After checking the play of the hand operated lever, retighten the nut.

Fig. 45

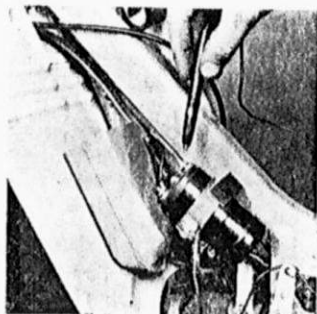

## 60. The defect of the undercarriage

a) Loosened engine in the frame.

The defect appears as a heavy knocking of engine when putting the motorcycle into the operation. Clear it by retightening the engine screws.

b) Seized front telescopes.

The defect is cleared by polishing the sliders and by lubricating them.

c) Rear telescopes shocking.

The defect is cleared by changing or replenishing the oil in the telescopic shock absorbers according to the chapter 17 (fig. 42).

## 61. Ignition defects

1. The engine is not able to be started since it stops suddenly and does not start even when operated further more.

The defect may consist in the fuel supply, carburetter and ignition. Should the fuel supply be in order and plenty of petrol, check whether the plug is giving the spark. The most frequent defect consists in the plug itself (oiled plug, injured plug insulation, short circuiting between the electrodes and big distance of the electrodes). Try therefore the sparking when screwing out the plug. If there is no spark between the electrodes when starting, respectively if the spark is weak, check and try whether the spark appears on the cable end and whether it is sufficiently strong. Should the defect consist in the plug (at the cable end appears a spark), repair or change the plug. Should the spark be weak even on the cable end, the defect may consist in the attenuation of the permanent magnets. The voltage is measured on the stator lighting winding with the lights switched-on.

No spark on the cable end (fig. 43).

Possible defect:

Dip switch of the lights in the stop position!

Defect in the contact breaker.

Verify the contact breaker and clear the defect.

Faulty condenser — change it.

Water in the contact breaker — blow out and dry-off the breaker.

Damaged ignition coil. Change the coil.

Damaged cable terminal. Change the terminal.

Interrupted or loosened cables from the magneto ignition winding up to the contact breaker and up to the plug.

Short circuit of the cables onto the body structure.

Check the conductors, repair resp. changes them, if required.

If there is no spark either on the cable end or on the coil outlet and the defect is not able to be ascertained with current method, this is to be found successively with help of the lamp tester with battery (dry cell) and respectively with A. C. voltmeter.

One test lamp outlet (the series connection of the hulk with battery) connect to the vehicle body structure. With the opposed outlet check the individual circuits. Disconnect the cables from the clamp (1) on the coil. Connect the

test lamp to the cables leading to the contact breaker and rotate partially the engine. If the bulb lights all the time, the failure may consist in the short circuit of conductor 1 on the body structure, resp. discharged condenser. In case the bulb flickers after having disconnected the condenser with engine rotating, change the faulty condenser, resp. eliminate the surface short circuit. In the contrary case look after the cable 1 or contact breaker short circuits where also does not occur any contact break due to scratching the contact breaker finger. If the bulb does not light at all with engine rotating, the defect may consist in the faulty connections or in the interrupted cable 1, burnt contacts, broken or weakened contact breaker spring. The defect is confined more closely by checking directly the contact breaker with tester.

## 2. Engine does not work regularly — it fails sometimes.

### a) The spark is correct

Except the carburetter and fuel supply defects, this may consist in the occasional short circuiting of cables leading from the magneto to the contact breaker or to the switch of the lights or it may consist in the interruption of the ignition cables. The reason causing the short circuit is to be ascertained and cleared, the faulty cables are to be changed or wrapped with insulating tape. Retighten the connecting clamps of the conductors and secure them with varnish.

### b) The spark is irregular

The defect may be caused by oiled or improper plug — change or clean the plug

A big distance of the plug electrodes: the distance is to be adjusted to 0.5 mm or 0.019 in. The fouled or burnt breaker contacts. Clean the contact with rag soaked with petrol and with a fine file.

Wrongly adjusted distance of breaker contacts. The distance is to be adjusted to abt. 0.4 mm or 0.015 in.

A faulty condenser, the engine is running at low r. p. m. Regular and strong sparking between the breaker contacts. — Change the condenser.

Occasional short-circuiting of cables as with a proper spark.

## 3. The engine does not stop when changing over the switch of lights to the stop — position.

Interrupted cable 1 from the ignition coil up to the switch of lights. Faulty connections of cable 1 on the coil or on switch. Faulty contact of switch of lights (clamp 31) to the body structure. Oxidized contacts in the switch of lights.

## 62. Defects of lighting

Burnt bulbs. Change the bulbs.

Loosened supply leads in the clamps (55, 56, 58) or interrupted cables. Fix the supply leads, check the soldering on the switches, repair or change the cables. Faulty dip switch or switch of lights. Clean the contacts, repair the

dip-switches or change them. Short circuit of the cables 55, 56, 58 to the structure body. The reason of the short circuit is to be revealed and cleared. Repair or change the cables. The short circuited cable is to be revealed by a successive disconnecting the cable. Above all change over the dip-switch to the position "day drive", then start the engine and depress the buzzer push button.

If the buzzer does not signal sufficiently the short circuit is caused by the clamp 56 on the switch of lights up to the lamp. Change over the switch to the position "night drive", disconnect successively the individual conductors of bulbs up to the switch of the lights.

Faulty magneto — short circuit or interrupted winding of the coil. Change the coil. The bulbs light faintly even with full engine r. p. m.

Used are the bulbs with a big input. Change by the 25/25 W/6 V and 5 W/6 V bulbs. Some of the cables is partially short circuited on the body structure. Wrong contact of the conductors in the clamps, oxidized clamps. Fix the cables, clean the clamps.

The short circuit in the coil of the lighting winding. Change the coil.

### 63. Defects of the sound signalling

The buzzer does not signal:

The buzzer defect is caused by the interrupted or short circuited cables from the clamp 55 on the switch of the lights through the push-button onto the body structure, wrong connections on the buzzer or push button clamps, wrong push-button contacts. The buzzer does not signal even with lights switched on and lower engine r. p. m. and with its complete detuning.

The cables are to be changed or repaired, the contacts cleaned and sprung. The burnt buzzer is to be changed.



## VII. SERVICE TOOLS FOR JAWA 50/23, JAWA 50/20 AND JAWA 50/21 MOTORCYCLES

M1	Box separator	for separating the engine box halves
M2	Mouting lever	for mounting clutch springs
M4	Advanced ignition gauge	ignition timing
M6	Chain wheel puller	to pull the crank mechanism bearing driven drum of clutch
M8	Rotor puller	to dismount the magneto rotor
M10	Piston pin removing device	to remove the piston pin
M12	Centring needle	to center the holes while assembly of engine into the frame
M13	Bush driver	to drive the centring bushes of engine
M15	Straightener of lock washers	while disassembly it serves to straighten the washers under the nuts of secondary wheel and driven drum of clutch, while assembly it serves to bend the washers.

M1

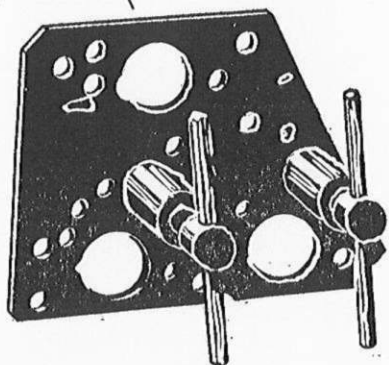

M4



M6

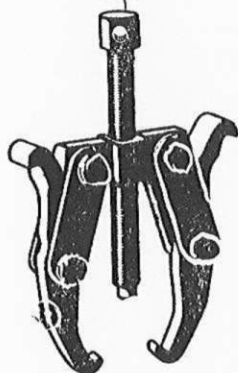

M2

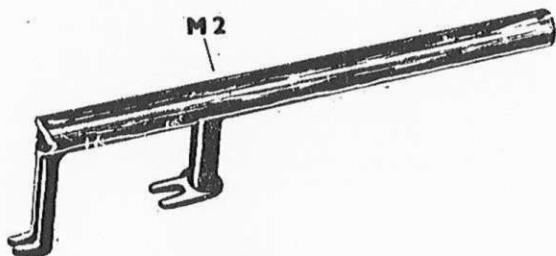

M10

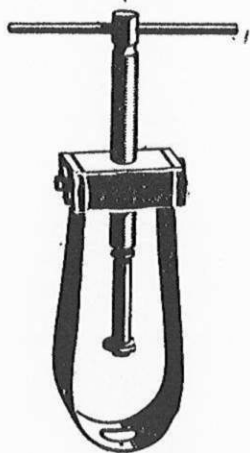

M8



M12



M13

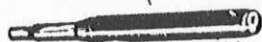

M15



---

Published by After — Sale Service Department, Považské strojárne, Nat. Corp.,  
Považská Bystrica

Printed by Tlačiarne SNP, Nat. Corp., Ružomberok.  
CZECHOSLOVAKIA



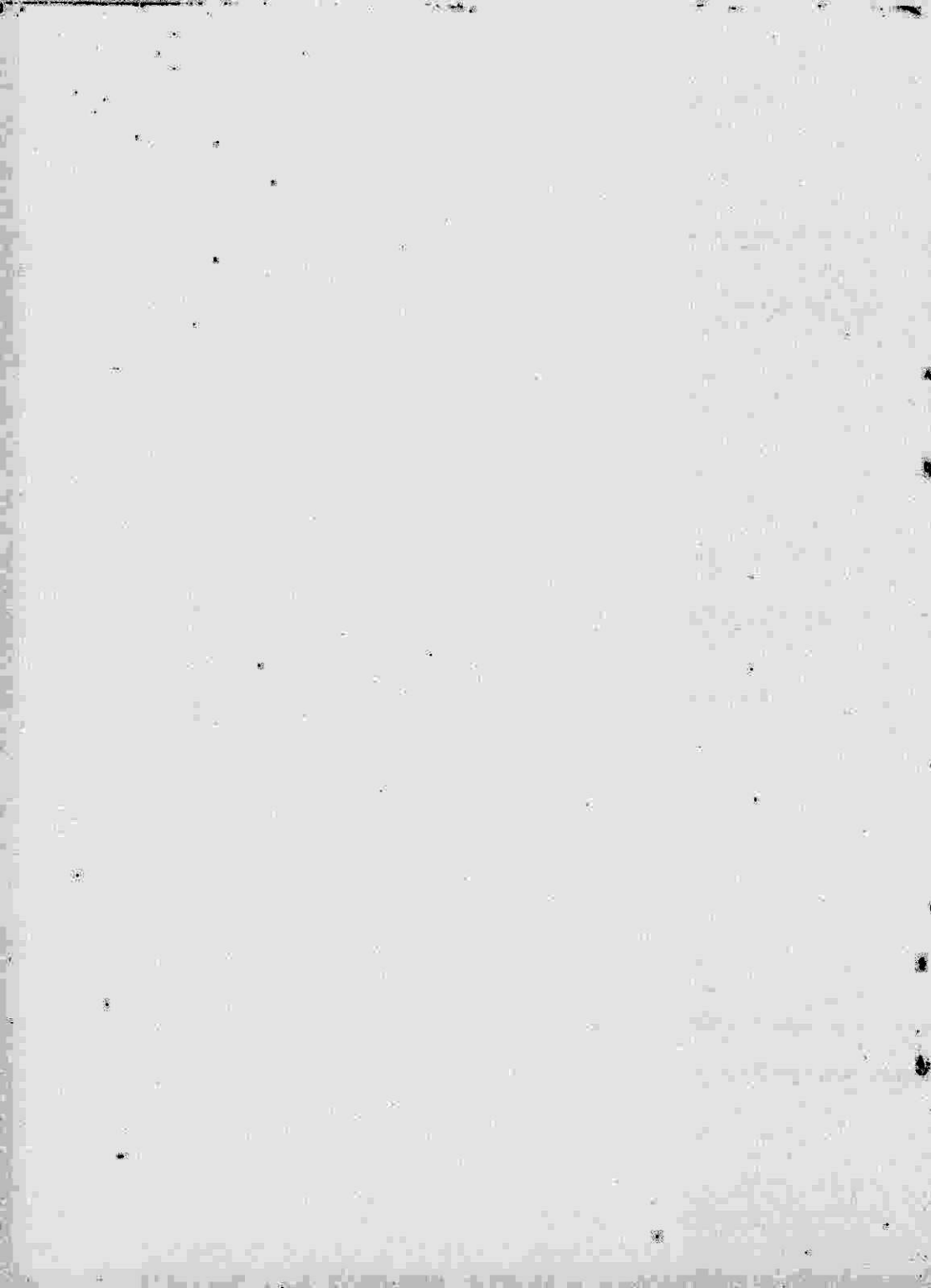

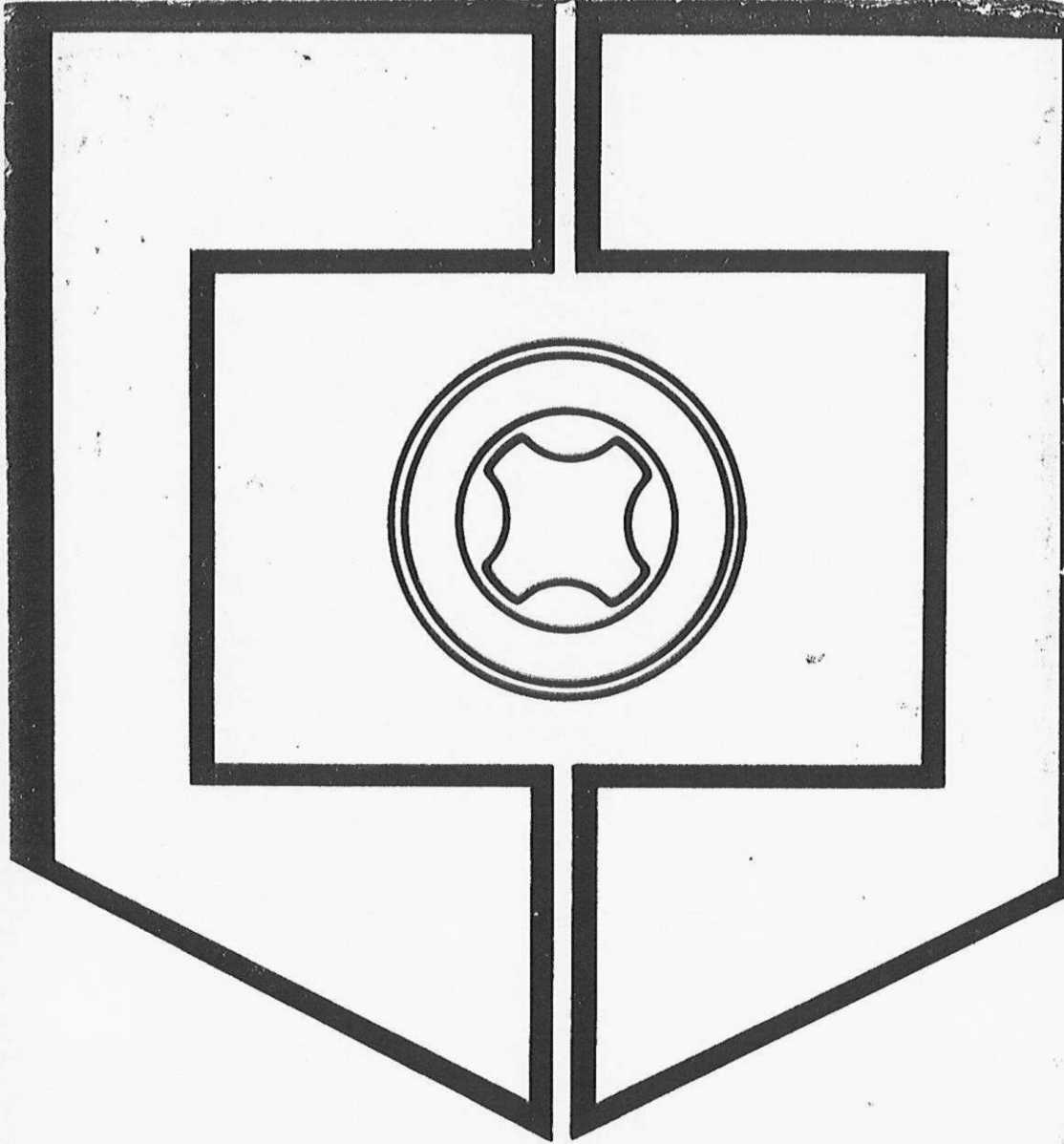

**POVAŽSKÉ STROJÁRNE, N. P.**  
**POVAŽSKÁ BYSTRICA**

CSSR

# IceniCAM Information Service

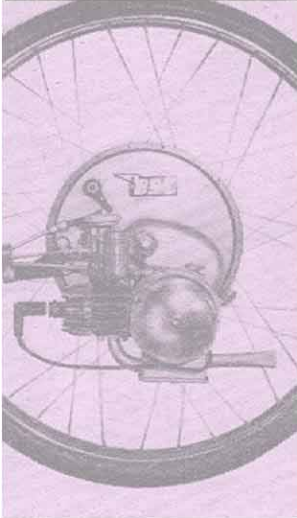

[www.icenicam.org.uk](http://www.icenicam.org.uk)