



Cyclo

The Gear without a doubt.

Cyclo

CONDITIONS OF SALE

EXPORT.—In view of our existing arrangements abroad, Merchants are kindly requested to state the name of the market for which our goods are required.

All orders to be confined through recognised Merchants or Shipping Houses. Packing Free and Carriage Paid to English Port for orders over £100. Otherwise, prices to be understood, Works, Birmingham.

HOME.—Retail clients are advised, in the first place, to approach their local Cycle Agents for any of our lines listed in this booklet, but if supplies cannot be obtained for any particular reason, please write to us.

NOTES AND RULES WHEN ORDERING SPARES

Parts sent as patterns should be marked with sender's name and address, or advice enclosed from senders with the necessary instructions ; this will ensure immediate attention.

Prices do not include cost of postage or passenger charges unless otherwise quoted. As far as possible we give illustrations of spares, number and description ; we recommend when in doubt, however, to return the old part, and, as far as possible, state on the advice enclosed with the part the description, such as : pawls, screw, spring, brake cam, etc.

Customers having no account with us are requested to remit when sending the order, including postage. If the remittance exceeds the cost of the parts, the balance will be immediately refunded when sending our invoice and receipt.

GUARANTEE

We guarantee all our products as regards material and workmanship, and any parts which in our judgment show defects in these particulars will be replaced, provided they are returned to us for inspection, carriage paid, within a reasonable time. Parts replaced shall not form the subject of a claim for labour or any other expenditure, nor shall we be liable for any direct or consequential damage arising from any defect.



Introduction

IN presenting this latest catalogue it is our earnest desire to provide for our overseas friends who are interested in all that is best concerning British bicycles. We do this with every confidence because we are the largest specialised manufacturers of high grade accessories, including the world-famous "CYCLO" derailleur gears.

"CYCLO" derailleurs are Britain's best sellers. They are not merely fitments for sports models as may be generally supposed, but afford equal improvement to standard roadster machines. Racing performances over a period of years by the world's best known riders were only a means to prove the reliability and the necessity for a variable gear and its advantage to the rider. In this sphere of the sport and in design, quality and finish, "CYCLO" remains supreme in continuous leadership.

We trust this booklet will assist you in choosing a "CYCLO" equipped machine, offered in the world's finest range of British bicycles. A "CYCLO" gear can be incorporated on any single speed standard roadster specification at an extra cost consistent with the usual maker's charge.

"CYCLO'S" best reference is the appreciation of millions of riders in all parts of the world.

Cyclo Successes

Prior to the war years, "CYCLO" equipped machines were sweeping the board in practically every important road event. A few of the many successes in the Record Book are briefly detailed as under:—

1926 to 1937

Over 3,000 Firsts from all parts of the World.

International Variable Gear Championship Winners 15 years in succession.

Unpaced Year's Cycling Mileage Record 1933-1938.

100,000 Miles Unpaced Cycling Mileage Record 1937-1938.

Unpaced World Road Records Holder, 1938
24 Hours—505½ miles.

HUBERT OPPERMAN

THE WORLD'S GREATEST RIDER OF MODERN TIMES

Rode 1,000 Miles
in
63 Hrs. 37 Mins.

PREVIOUS BEST: 70 Hours 40 Mins.

STILL STANDS TO-DAY

1919 Successes

include the following amongst many others:—

National Road Championship (British League of Racing Cyclists).

Midland Road Championship.

Midland Time Trials Championship.

"King of the Mountains" Title—Brighton to Glasgow 6-day Marathon.
"News of the World" Trophy won by Joe Spragg.

"King of the Hills."

National Hill Climb Championship.

World Hour Motor-Paced Record by Jose Meiffret of France covering the official distance of 87.918 Km. (54.64 miles).

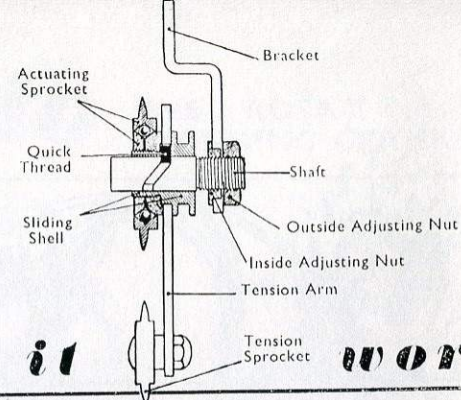

How it works

The "CYCLO" Derailleur Gear consists of a Freewheel with two, three or four sprockets, a mechanism for moving the chain into line with the respective Freewheel sprockets, controlled by a double cable and lever from the top tube of the cycle, or Handlebar Twist Grip Control, and a spring to take up the excess of chain between the smallest and the largest sprocket.

The Chain (5-8 links longer than usual) passes from the Chain Wheel and round the underside of the tension cog to the Actuating Sprocket, and from there round the Freewheel Sprocket, with which it is in line, and back to the Chain Wheel.

Any movement of the control lever or twist grip control, through the double cable, imparts a rotary movement to a quick thread on which the actuating sprocket is mounted, and this moves laterally into line with the cog selected. Providing the adjustment and gear-changing are correct, the cog takes up the chain without any suspicion of snatch or noise, but gear-changing is to a great extent a matter of practice and the expert is distinguishable from the novice by the absence of noise.

How to use it

When changing gear, pedalling should be kept up, then when the chain is taking up on the next cog, and the drive taken up once again at just the right time, changing will be noiseless. This is all a question of practice.

There is no appreciable friction on any of the gears, although two cogs must necessarily run very slightly out of chain line. This is allowed for by the tensioning cog, which, being of a special shape and small size, allows the chain to run very freely. The actuating cog leads the chain in a straight line on to each sprocket, and all grinding on the drive is thus avoided. It is impossible to tell from the "feel" on the drive which gear is in use on a properly adjusted "CYCLO".

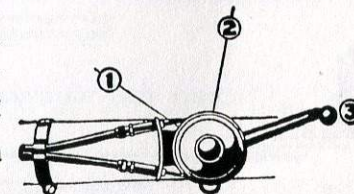

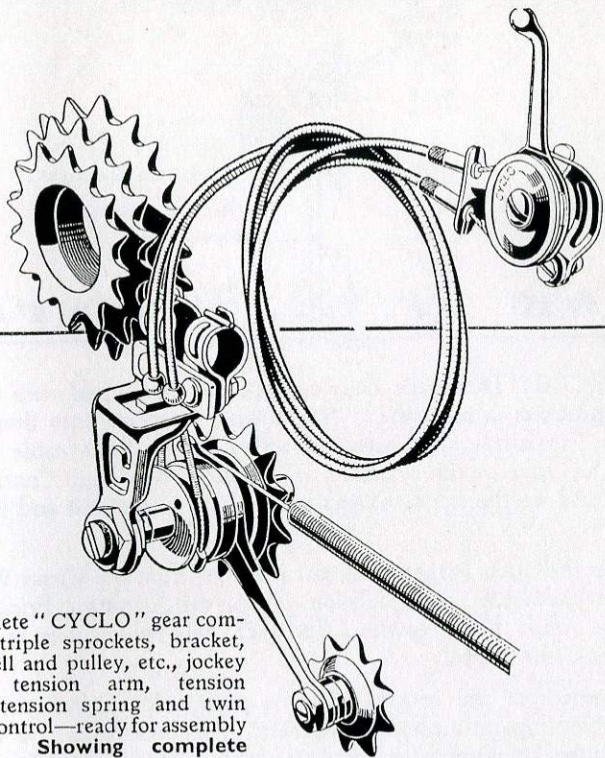

The complete "CYCLO" gear comprises of triple sprockets, bracket, sliding shell and pulley, etc., jockey sprocket, tension arm, tension sprocket, tension spring and twin cable and control—ready for assembly to cycle. Showing complete 3-speed as supplied.

Instructions for "Dishing" a cycle wheel for "Cyclo" Gears

To fit a "Cyclo" gear to a cycle wheel it is essential that the rear wheel should be dished in the following manner with the use of a nipple key.

First fit a "Cyclo" long spindle with a long cone, on the freewheel side; this long spindle with suitable cone is supplied by us.

Secondly loosen all the nipples on the plain side of the wheel one and a half turns, starting from the valve hole, then tighten the nipples of the spokes on the freewheel side ONE TURN ONLY all the way round.

When this is done the rim will run central in the frame, and this will also cause the middle gear sprocket to run in line with the chain wheel (see illustration). This, of course, providing that the gear has been adjusted in accordance with the usual instructions.

The wheel dishing is not required if using a flush Universal Type Triple free-wheel, which only needs a packing washer both sides of spindle to centralise the wheel between the seat stays.

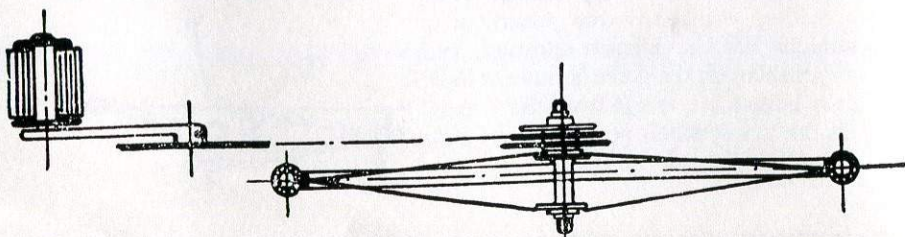

Cyclo TWO-SPEED

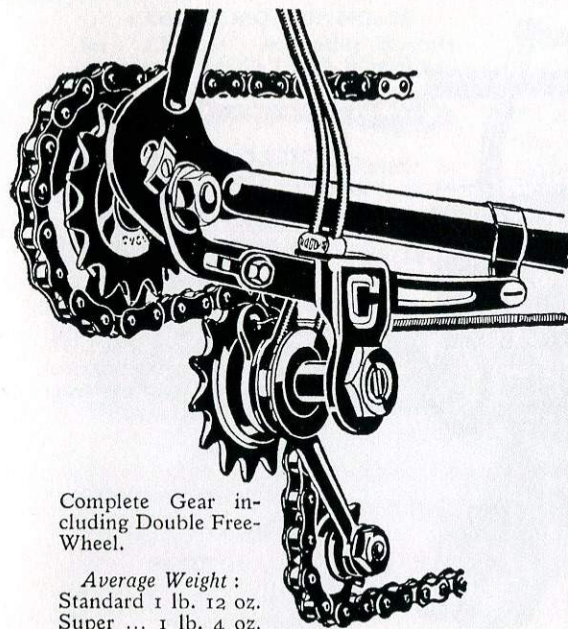

Complete Gear including Double Free-Wheel.

Average Weight :
Standard 1 lb. 12 oz.
Super ... 1 lb. 4 oz.

Showing 2-Speed fitted with Universal Clip-on Bracket, suitable for all types of chain stays. For alternative types of brackets see page 13.

The "CYCLO" Two-Speed Gear can be fitted to any existing wheel and requires NO ALTERATION except a few links of chain to be added to existing chain. We recommend this type of gear in particular when no alteration to wheel is required.

PRICE

2-Speed Cycle	...	35/-
2-Speed Tandem	...	37/6
Pulley (Extra)	...	2/9

Fitting charges extra.



DOUBLE FREEWHEEL.

Stock Sizes.

Top: 16 th.
Low: 18-19-20-21 up to 26: h.

"CYCLO" TWIST GRIP CONTROL

(For 2, 3 or 4 Speed)

FITTING INSTRUCTIONS

Drill a 5/32" hole on the centre line of the outside of the handlebar, slide over the twist grip sleeve, and insert pin, screwing nut from the inside of the tube. The head of the pin acting as a stop at each extreme end of the slot. To slip the rubber grip easily over the extra thickness smear the sleeve slightly with grease. The transmission is fitted according to the usual "CYCLO" fitting instruction. Copy free on request. N.B.: When ordering please state size of frame, solo

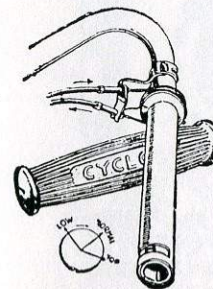

or tandem. Twist grip sleeve can be shortened to suit any handlebar length. The Set comprises: Twist Grip, Dummy, to match, together with Transmission to suit. Conversion Set for "CYCLO" users.

SOLO ... 12/6 TANDEM ... 13/6

Twist Grip Control can be supplied for 2, 3 or 4 speed gears at extra cost of ... 8/6

(See enlarged illustration on page 23.)

Small Chain Wheels and small Sprockets mean less Chain, less friction, easier action and saving of weight.

All good Cycle Dealers recommend and fit "Cyclo" gears.

Cyclo THREE - SPEED

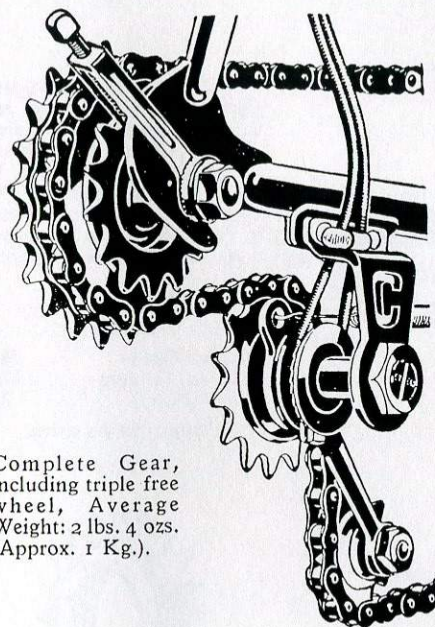

Complete Gear, including triple free wheel, Average Weight: 2 lbs. 4 ozs. (Approx. 1 Kg.).

Showing 3-speed fitted with detachable and adjustable brazed-on bracket.

For alternative types of brackets, see page 13.

"CYCLO" involves no loss of speed when changing down—no excessive revolving weight or wasteful friction. Offers a wide variety of gear proportions to suit the rider's exact requirements. With "CYCLO" all parts are standardised, readily accessible and easily interchangeable. "CYCLO" provides the complete solution to the variable gear problem.

STANDARD "CYCLO"

3-Speed Solo or Tandem.

PRICES

3-Speed Cycle	... 40/-
3-Speed Tandem	... 45/-
Pulley (extra)	... 2/9
Cyclo Dural	... 10/-
Fitting charge extra.	

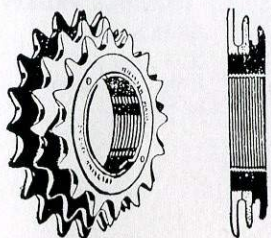

STOCK SIZES: TRIPLE FREEWHEELS

UNIVERSAL FLUSH BACK (Narrow type)

16 x 18 x 20 th.	up to 28 th
16 x 18 x 21 "	" " "
16 x 18 x 22 "	" " "

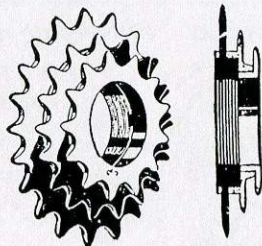

STOCK SIZES: TRIPLE FREEWHEELS

STANDARD "CYCLO"

13 x 17 x 21 th.	up to 28 th.
13 x 18 x 20 "	" " "
14 x 17 x 21 "	" " "
15 x 18 x 21 "	" " "

Choose a "CYCLO"-equipped machine—makers that fit "CYCLO" GEAR as standard equipment build well.

Cyclo FOUR-SPEED

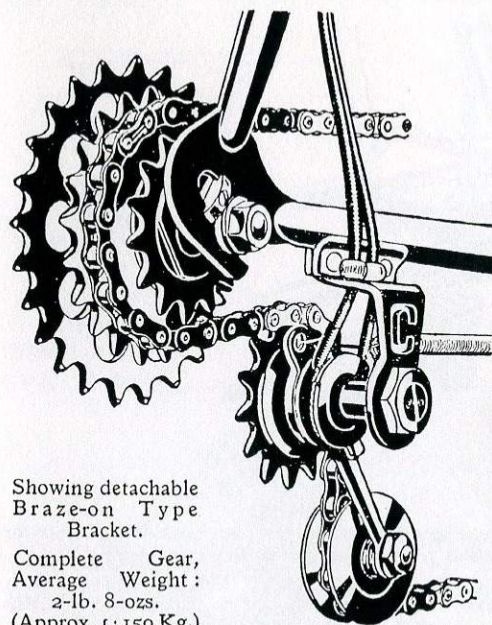

The "CYCLO" 4-speed Gear has been specially designed for the benefit of riders, for whom an extra Low Gear is a distinct advantage.

We recommend braze-on fittings in preference to clip-on whenever possible. This ensures a more rigid job, and neater appearance.

PRICE

4-speed Cycle	... 45/-
4-speed Tandem	... 50/-
Pulley (extra)	... 2/9

Fitting charges extra.

Showing detachable Braze-on Type Bracket.

Complete Gear, Average Weight: 2-lb. 8-ozs. (Approx. 1.150 Kg.).

Showing a 4-speed fitted with detachable and adjustable brazed-on bracket.

For alternative types of brackets, see page 13.

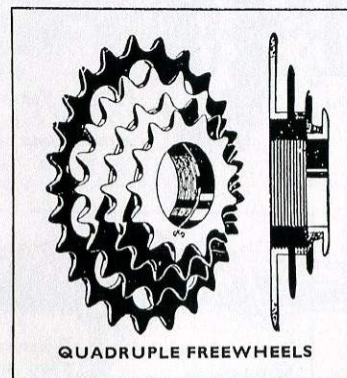

STOCK SIZES: QUADRUPLE FREEWHEELS

Top	... 13, 14, 15 th.
Third	... 17, 18, 19 th.
Second	... 20, 21, 22 th.
First	... 21, 22, 23 up to 28 th.

For all round serious cycling — choose a "CYCLO"

Cyclo CALLING ALL HUB GEAR USERS

SIX-SPEED HUB GEAR CONVERSION SETS

PRICE 32/6
(top tube control)
Tandem 5/- extra

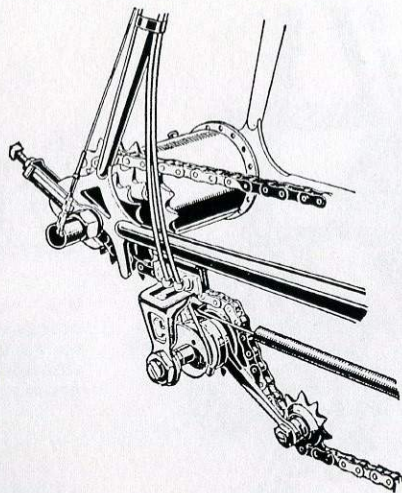

NINE-SPEED HUB GEAR CONVERSION SETS

PRICE 37/6
(top tube control)
Tandem 5/- extra

Now, the new double or triple fixed sprocket block, complete with Cyclo Gear for cycle or tandem, converts your existing 3-speed hub to a 6- or 9-speed gear.

SPECIAL FEATURES: No alteration to the wheel or spindle. The triple version is so arranged whereby chainline is obtained on the middle gear as soon as the specially designed sprocket block is fitted on the existing hub freewheel body.

The remainder of the gear is fitted in the usual way with chain stay bracket fitments to customer's choice. Can also be fitted with either top tube or twist grip control. The only modification required is the adding of 4 links to the existing chain.

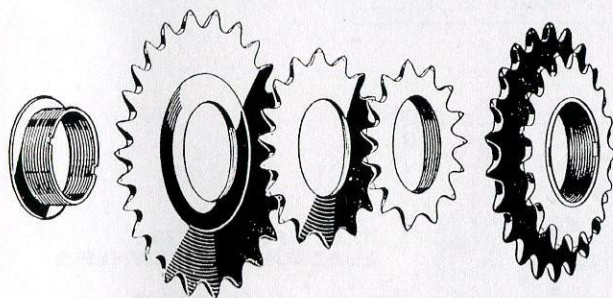

Double Fixed

Block only
To suit screwed or splined Sleeve.

Top 13 to 18 inc.
Low 16 to 22 inc.

Note: For splined fitting top gear sprocket can only be 13 to 16 inclusive

Triple Fixed

Top 13 to 18 inc.
Middle 17 to 22 inc.
Low 24-25-26-28

Block only

Sprocket Blocks. Further details see page 21.

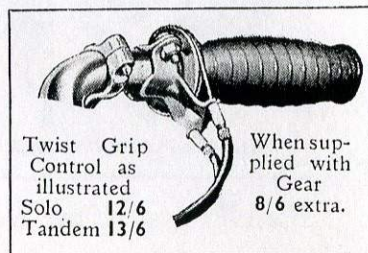

Twist Grip Control as illustrated
Solo 12/6
Tandem 13/6

When supplied with Gear 8/6 extra.

Order through your local Cyclo Agent or, if in any difficulty, please write to us

Cyclo "ACE" THREE-SPEED

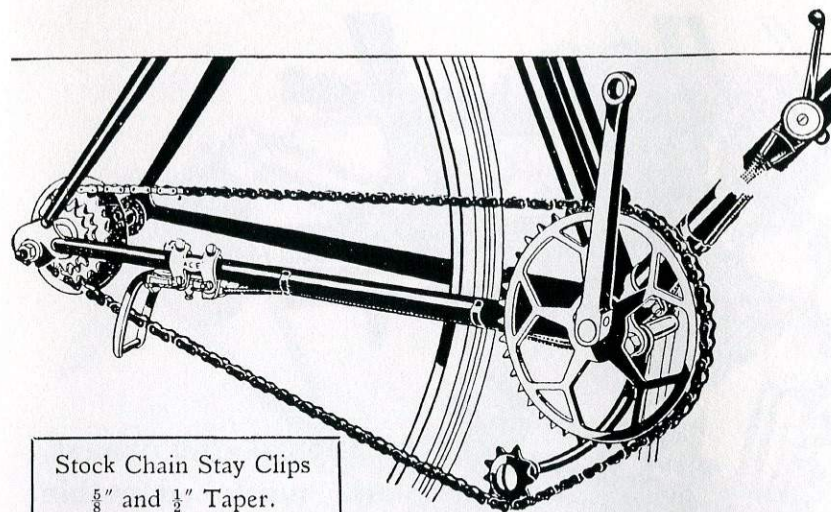

Stock Chain Stay Clips
 $\frac{5}{8}$ " and $\frac{1}{2}$ " Taper.

By reason of its design, this gear is strictly limited to close ratios recommended below. It is simple and efficient. The proved "Cyclo" twin-cable control is retained to give fault free changing and trouble free service. The "Ace" is sold complete with spoke disc as illustrated. Although limited in use to the close ratio fraternity, we can nevertheless state that the performance and action of this gear make it the leader of its class.

Complete Gear, Average Weight: 1 lb. 8 ozs.
(Approx. 0-Kg. 7.30 Gr.)

PRICE 35/-

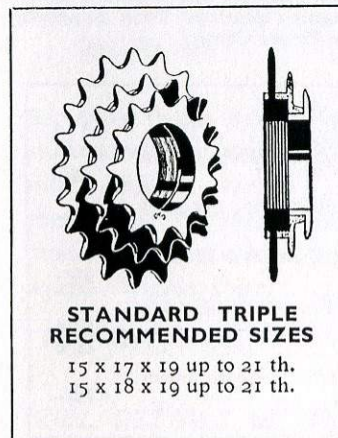

STANDARD TRIPLE RECOMMENDED SIZES

15 x 17 x 19 up to 21 th.
15 x 18 x 19 up to 21 th.

"ACE" SPOKES PROTECTOR



REF. No. A/1
Made of polished aluminium. Pierced to screw on dead centre to hub thread. Recommended for all types of derailleurs except "CYCLO".

Price ... 1/- each.

The Ace
Racing Man's Favourite

Cyclo

BENELUX

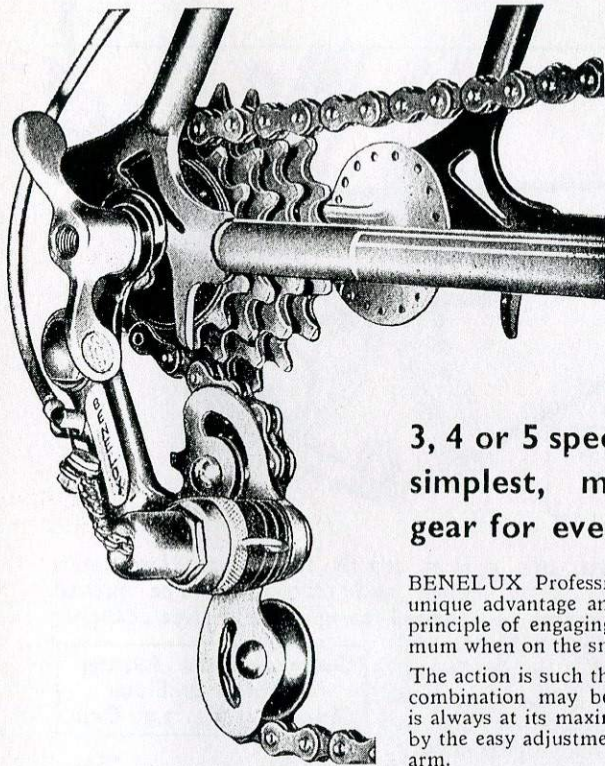

3, 4 or 5 speed—the newest, simplest, most adaptable gear for every requirement

BENELUX Professional type Gear has the unique advantage and the well-known Cyclo principle of engaging the chain to the maximum when on the smallest size Sprocket.

The action is such that whatever the Sprocket combination may be, the chain engagement is always at its maximum, this being obtained by the easy adjustment of the fixed adjustable arm.

The system's patented feature provides closest contact between cog and jockey sprocket to give a snappy change action, and will work perfectly with Standard Cyclo Freewheel teeth form as the BENELUX is not necessarily a close ratio Gear. Supplied with either BENELUX Handlebar Control or Cycle Frame Control.

GEAR PRICES

Price complete with Standard Cyclo 3-speed Freewheel (Pointed Form Teeth) for $\frac{1}{2}$ " x $\frac{1}{8}$ " Chain only	45/-
Price complete with 4-speed Cyclo Freewheel as illustrated. (Pointed Form Teeth) for $\frac{1}{2}$ " x $\frac{1}{8}$ " Chain only	50/-
Price complete with Benelux Boss type 3-speed Freewheel (Square Form Teeth) for $\frac{1}{2}$ " x $\frac{1}{8}$ " Chain	50/-
Price complete with Benelux Boss type 4-speed Freewheel. (Square Form teeth) for $\frac{1}{2}$ " x $\frac{1}{8}$ " Chain	57/6
For $\frac{1}{2}$ " x $\frac{3}{32}$ " Chain	62/6
Price, complete with Benelux 5-speed Freewheel. (Square Form Teeth) for $\frac{3}{32}$ " Chain only... ..	70/-

The gear that wins races everywhere

Cyclo

CHAIN SHIFTERS & DOUBLE CHAIN WHEELS

By fitting a "ROSA" Double Chain Wheel you can select any size listed. With "ROSA" Chain Wheels you are not limited to so-called "standard sizes."

"ROSA" Double Chain Wheels can be coupled to suit your requirements.

STOCK SIZES:

Chain Wheels:

50-48-47
46-44-42
40-38-36TH.

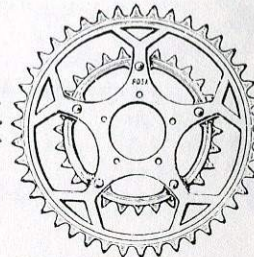
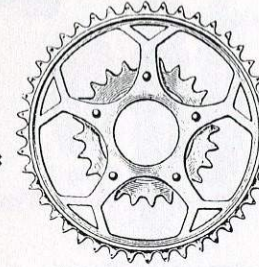

Select your own ratios by specifying double Chain Wheels

STOCK CHAIN RINGS

48-47-46
44-42-40
38-36-34
32-30-28-26-24 TH.

B.S.A.—5-Pin pattern only, complete, as illustrated.

Price:

$\frac{1}{8}$ " Chain Wheel only ... 18/-

$\frac{3}{32}$ " " " " ... 5/- EXTRA.

Combinations to specification—Price

per set less crank 30/- For $\frac{1}{8}$ " chain.

" " " " 39/- For $\frac{3}{32}$ " chain.

Standard Finish Chrome

"Rosa" Chain Shifting Device

Patent No. 370835.

EFFICIENT AND EASY FITTING

Designed for double and triple chain wheels to shift the chain automatically from one chain wheel to another and vice-versa.

HAND CONTROL CHAIN SHIFTER

Supplied for both close and wide ratio.

Racing close ratio type R.

Touring wide ratio type T.

Price 30/-

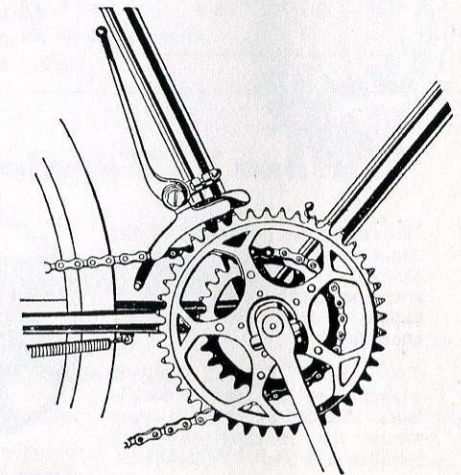

Cyclo AND "ROSA" SYSTEMS

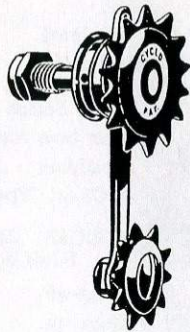

Standard "Cyclo"
2-Speed System ... } 16/10
3-Speed System ... }
Pulley Type, 2/9 extra.

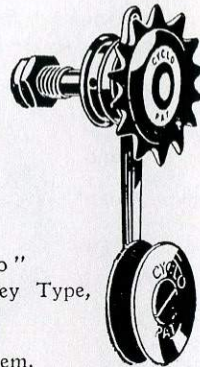

Standard "Cyclo"
3-Speed System, Pulley Type,
25/-
4-Speed 29/3
Duralumin System.

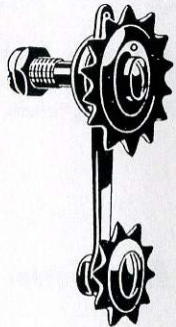

"Rosa" Sliding Jockey Tension Device. Complete with Tension Spring and Bracket.

Specially designed for floating chain and other various adaptations.

Price 21/-

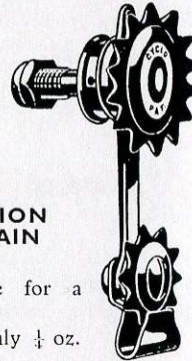

"ROSA" TENSION SPROCKET CHAIN GUARD

An efficient substitute for a Pulley.

Aluminium—Weights only 1/4 oz.
Price : 8d. each.

Systems 2-3 or 4-Speed can be serviced at an inclusive charge of 10/9

"Rosa" Tension Pulley (Patent)

Eliminates the possibility of the chain jumping over pot holes. Specially recommended for strenuous riding conditions of racing. It tends, also, to perfect chain line.

The "Rosa" Tension Pulley is adaptable to any type of derailleurs. Should be fitted to gears where the number of teeth between LOW and TOP exceeds 10.

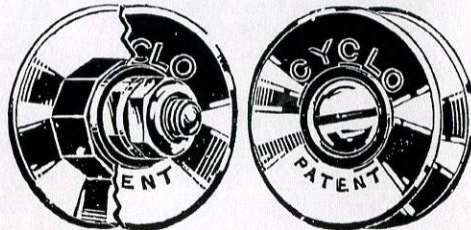

Dural Flanges. Weight 3 oz. Price 5/6

Cyclo BRACKETS AND FORK ENDS

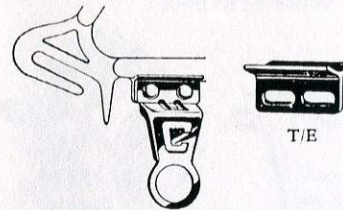

"CYCLO" DETACHABLE AND ADJUSTABLE BRAZED-ON BRACKET

The top part of this bracket (T/E) is supplied free of charge to any manufacturers or builders. The bottom of the bracket to be supplied with the gear when ordered. Price 2/2

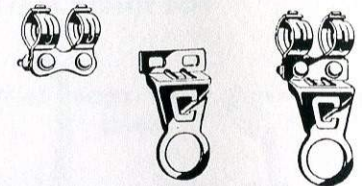

Ref. 01/C and B/L

Round Detachable for 1/2" Standard 1/2 and 3/4" Round Tapered Stay, complete with B/L Bracket.

Clip only, 1/6

Complete, 3/8
B/L only, 2/2

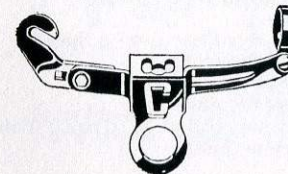

Ref. "UNIVERSAL"

Detachable "CYCLO" Bracket for Standard 3 and 4-Speed "CYCLO". Will suit any type of fork end or chain stay. Price complete, 3/-

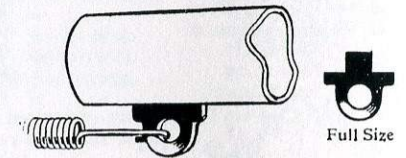

"CYCLO" TENSION SPRING EYE

Ref. No. 26

Braze-on Eye (as illustrated).

Full Size

2d. each

When ordering, please state which pattern and size are required.
We advise the use of the braze-on attachment wherever practicable. This should not disfigure the machine even when fitted to an existing frame. This makes for rigidity unobtainable with any bolt-on attachment.

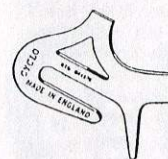

CONTINENTAL FORK ENDS with CHAIN SPIGOT

Ref. No. 153
1/6 per pair.

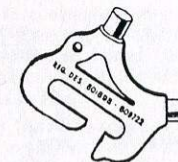

"CYCLO" DOUBLE-PURPOSE FORK ENDS

Ref. No. 371.
Suitable for all types of Sports frames. Solo Type. 1/6 per pair.

This Fork End gives an adjustment for the gear if the owner desires to change his gear ratios by the fitment of new back cogs.

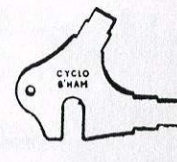

STRAIGHT DROP OUT FORK ENDS

Ref. No. 372
1/- per pair.



MODERN DESIGN FRONT FORK ENDS

Ref. No. 154.
5/16 opening with Mud-guard eye.
1/- per pair.

Cyclo DERAILLEUR GEAR CONTROLS

FOR SINGLE AND DOUBLE WIRE SYSTEMS

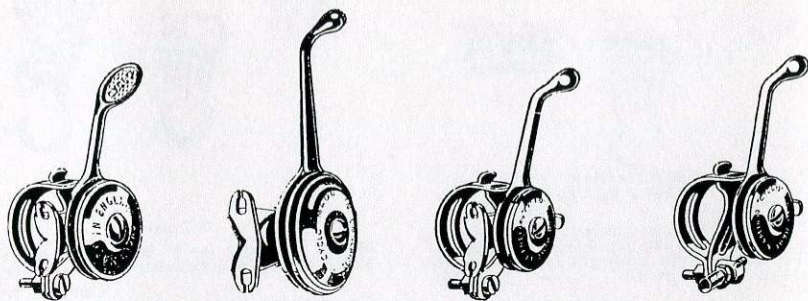

- | | | | |
|----------|-----------------|---------------|-------------------------------------|
| A | — Ref. C/20/26 | Control Lever | Standard for Cyclo 2-3-4 Speeds. |
| B | — Ref. CB/20/26 | " " | Braze on type " " " " " " |
| C | — Ref. OA/20/26 | " " | for Oppy and Ace Gear 2-3-4 Speeds. |
| | Ref. OAB | " " | Braze on type for above. |
| D | — Ref. 19/25 | " " | for Super Olympic 3 and 4 Speeds. |
| | Ref. B/19/25 | " " | Braze on type for above. |

N.B. All Clip-on Type Levers illustrated above can be supplied for $\frac{7}{8}$ ", 1" or $1\frac{1}{8}$ " Tubing. Please state size required when ordering.

Price 5/-

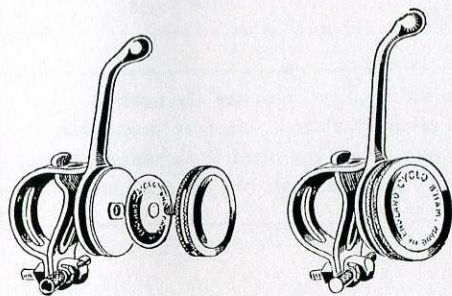

Ref. CD. CONTROL LEVER DAMPER

Will fit any Cyclo lever single or double wire type as illustrated above. The Cyclo damper enables the rider to adjust or lock up the control at will and in a most convenient way. Readily fitted. Price 2/6

Super Chrome finish. Weight $\frac{3}{4}$ oz.

Cable transmissions can be made tidy and look neat if you use Cyclo Duplex patent quick detachable clips.

Made for $1\frac{1}{8}$ " and 1" tubing.

Price 6d. per pair

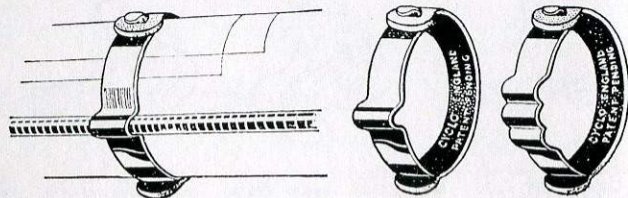

$\frac{3}{8}$ " Spring Stay Clip. 2-way as illustration. Price 2d. each.

BENELUX

HANDLEBAR GEAR CONTROL

Main features:—Readily fitted, NO DRILLING OF THE HANDLEBAR, ADAPTABLE TO ALL CONTINENTAL SINGLE WIRE RACING GEARS. Used by the 1949 Tour de France Riders and World Championship Professionals. For quick change you must use "BENELUX".

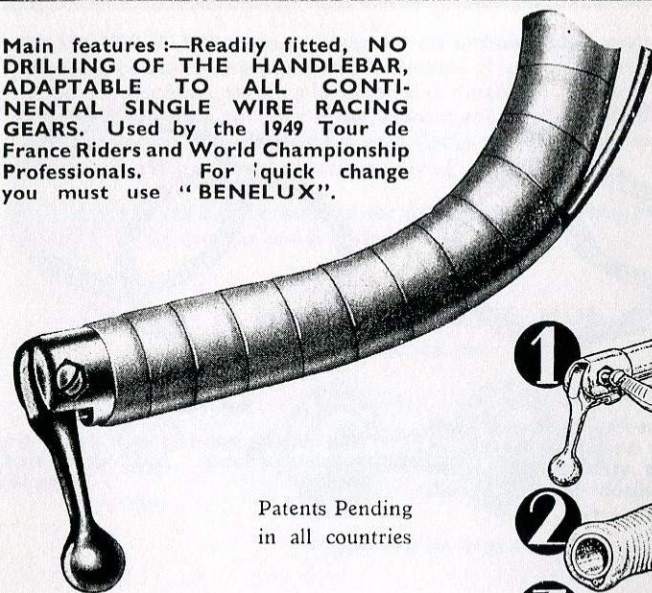

Patents Pending
in all countries

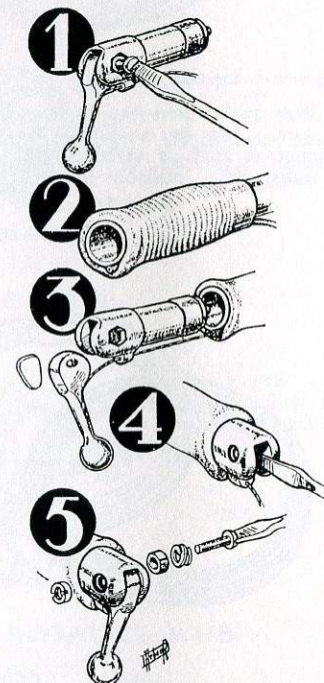

Gives complete control of your derailleur gear change, without removing your hands from the handlebars.

Instead of the usual control lever mounted on the down tube, BENELUX is fitted into the end of the handlebar bend, either left or right as you wish.

Don't waste valuable seconds searching for the control lever, fit a BENELUX and change at will, and at speed. (Fits all single wire Derailleurs.)

Price 10/6 complete with handlebar length transmission.

Instructions for fitting the "BENELUX" Control

Completely unscrew the central screwed pin.

Pass the outer casing between handlebar and grip. (See illustration.)

Slip cable, previously well greased, in the casing. Push the body of the Benelux Control well into the handlebar. (See illustration No. 3.)

Tighten the expander screw. Expander screw to be well screwed up.

Replace the brass screw, the spring washer and the central screwed pin.

Screw the latter so as to obtain the necessary tightening of the lever.

Connect the other end of the cable to the derailleur and regulate as you would with a standard control lever.

Manufactured in England under sole exclusive licence by Cyclo Gear Co. Ltd.

Cyclo HIGH GRADE PRODUCTS

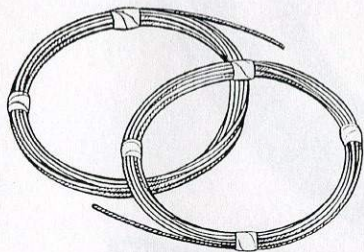

Ref. No. C/2

Best quality non-fray 12 strands cycle wire. Can be used for all types of controls such as carburettors, 3-speed hubs, etc. Available in 100 ft. coil.

Price 7/6

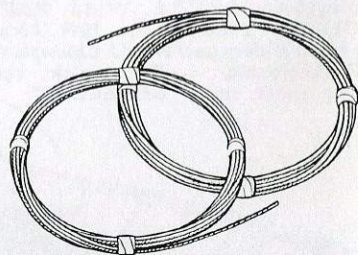

Ref. No. C/3

Best quality non-fray cycle brake wire size 1-14 strands. Available in 100ft. coil. Price 10/6

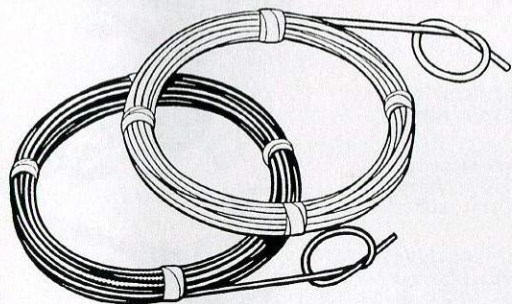

Ref. No. C/1

Waterproof covered Cycle Brake, size 1, finished in black, red, blue, silver and cream. Available in 100 ft. coil. Price 25/-

Ref. No. 32B

Patent nipple with inner wire non-fray. Cycle length size. Price 1/7 each.

Ref. No. 32/T

Patent nipple with inner wire non-fray. Tandem length size. Price 2/2 each

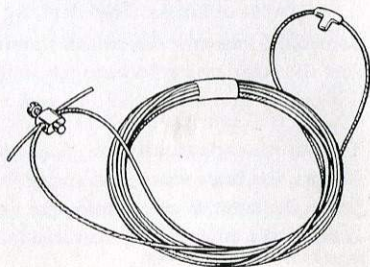

Cyclo RUSTLESS "ROSALITE" LIGHTWEIGHT HUBS

ROSALITE HUBS are manufactured from one-piece shell made from drop forged stamping of the highest quality tensile strength 35/42 tons per square inch. Hubs are accurately machined ensuring lightness with durability. The rear hub is eyeleted on the free wheel side to make spoke replacement simplicity itself. The free wheel threaded portion will accommodate both Cyclo and Boss type multiple free wheels, and yet the width over locking nuts is only 4 1/2".

The rear hub can also be supplied for single speed free wheel with off side double threaded for fix sprocket and lock ring.

FRONT ROSALITE HUB

Ref. No. 501

Finish highly polished complete with ROSA Track Nuts.

Price 12/6

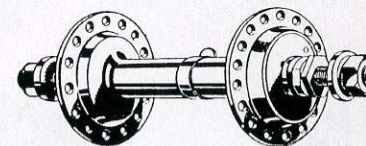

Flanges diameter: 1 3/8"

Width over Lock-nuts 3 1/8" drilling 32 holes.

Weight: 4 3/4 oz. (135 gr.)

REAR ROSALITE HUB

Ref. No. 502

Boss Type (as illustrated) Single sided thread 3/8" depth. Flange Diameter: 2 1/2". Width over lock nuts, 4 1/2". drilling 40 holes.

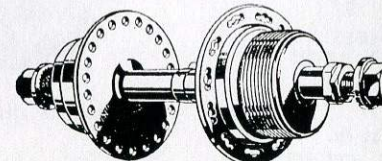

Finish highly polished complete with ROSA Track Nuts.

Price 16/6

Weight 10 oz. (280 gr.)

REAR ROSALITE HUB

Ref. No. 504



DURAL HUB LOCK RING Price 1/- each

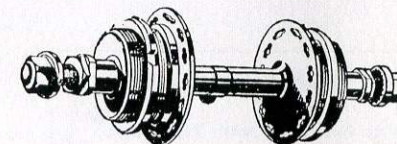

Ref. No. 503

Single Speed double sided type.

For Single Speed free wheel with off-side double threaded for fixed sprocket and lock ring.

Weight: 9 oz. (250 gr.) Drilling 40 holes.

Finish highly polished, complete with ROSA tracknuts 17/6

"ROSALITE" Hubs are best for Super Lightweight

Cyclo FREEWHEELS

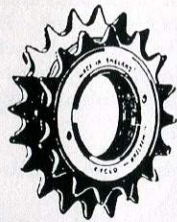

TWO-SPEED TYPE

Stock Sizes :—

Top : 16 th.—17 th.
Low : 18, 19, 20, 21/26 th.

Price : 12/-

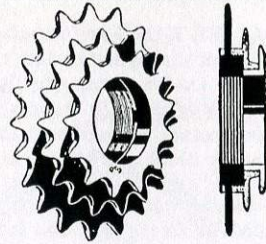

STANDARD TRIPLE FREEWHEEL

Stock Sizes :—

Top : 13, 14, 15 th.
Middle 17, 18, 19 th.
Low : 20, 21 th. and up to 28 th.

Price : 18/-

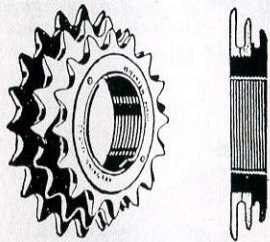

**TRIPLE FREEWHEEL
UNIVERSAL FLUSH BACK**

Stock Sizes :—

Top : 16 th.
Middle : 18, 19, 20, 21 th.
Low : 19, 20, 21 and up to 28 th.

Price : 18/-

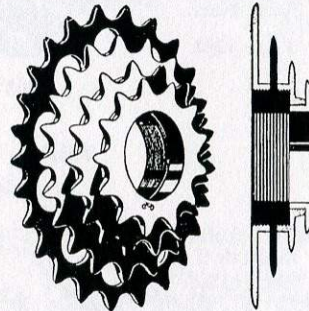

QUADRUPLE FREEWHEEL

Stock Sizes :—

Top : 13, 14, 15 th.
Third : 17, 18, 19 th.
Second : 20, 21, 22 th.
First. 21, 22, 23 and up to 28 th.

Price : 21/-

FREEWHEELS, SPROCKETS

	Price
2-Speed Freewheel Body with Top Gear sprocket, 16 th. ...	7/2
2-Speed Low Gear Sprocket 21, 22, 23, 24 th. ...	3/3
3-Speed Freewheel Body clutch less Sprocket ...	7/2
3-Speed ditto with Low Gear Sprocket ...	10/6
3-Speed Middle Gear Sprocket, 17, 18, 19 th. ...	5/6
3-Speed Top Gear Sprocket, 13, 14, 15, 16 th. ...	3/-
4-Speed Freewheel Body Clutch less Sprocket ...	7/2
4-Speed ditto with 2nd Gear Sprocket ...	10/6
4-Speed First Gear Sprocket, 25, 26, 28 th. ...	3/7
4-Speed Second Gear Sprocket, 21, 22, 23 th. ...	3/3
4-Speed Third Gear Sprocket, 17, 18, 19 th. ...	5/6
4-Speed Fourth Gear Sprocket, 13, 14, 15, 16 th. ...	3/-

"SERVICE" TRIPLE FREEWHEELS

Price 12/-

Cyclo BENELUX FREEWHEELS



BENELUX 3-SPEED BOSS TYPE (Square Form Teeth) For $\frac{1}{2}$ " x $\frac{1}{8}$ " Chain

Top : 14 to 15 th.
Middle : 16 to 17 th.
Low : 18 to 20 th.

Price : 20/-

BENELUX FOUR SPEED BOSS TYPE (Square Form Teeth) For Standard $\frac{1}{2}$ " x $\frac{1}{8}$ " or $\frac{1}{2}$ " x $\frac{3}{32}$ " Chain

Top : 14 to 15 th.
2nd. 16 to 17 th.
3rd. & 4th. 18 to 23 th.

Price for $\frac{1}{2}$ " x $\frac{1}{8}$ " Chain 27/6
For $\frac{1}{2}$ " x $\frac{3}{32}$ " Chain 32/6

BENELUX FIVE SPEED BOSS TYPE (Square Form Teeth) For $\frac{3}{32}$ " Chain only

Top : 13 to 14 th.
2nd.: 15 to 16 th.
3rd. : 16 to 19 th.
4th. & 5th. 18 to 23 th.

Price : 40/-

BENELUX SPROCKETS, 13 to 20 th. 4/6 ea. 21 to 23 th. 5/- ea.

BENELUX FREEWHEEL BODY, 4 and 5 speed : 20/-

"CYCLO" FREEWHEEL REMOVING TOOL.

Place the Remover face upwards in a vice and, with the pegs inserted in the slots in the Freewheel, turn the wheel round. The leverage obtained is sufficient to move the tightest Freewheel.

Best quality Siemen Martin spring steel—correctly hardened and tempered, cannot damage if correctly used. Remover should be packed level with washer so as to be solid on Freewheel base, then must be TIGHTLY secured into position by means of spindle nut.

These Removers are made for "CYCLO," Benelux and Standard Freewheels.

All types, Price 2/2 each.

When ordering, state which type is required.

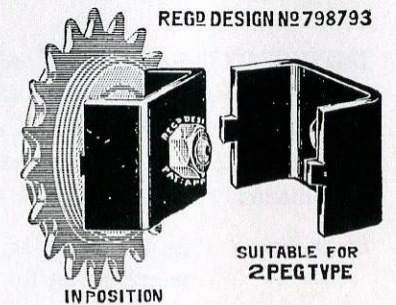

IN POSITION

SUITABLE FOR
2 PEG TYPE

Cyclo

STEEL and ALLOY HUB
SPROCKETS

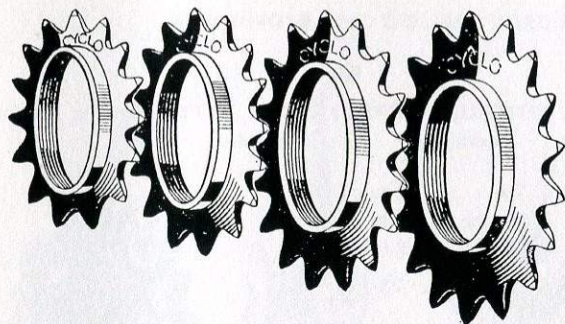

**ROSALOY
SPROCKETS
FOR SMOOTH
RUNNING
AND
LIGHTNESS**

Average weight of "Rosaloy" Sprocket, sizes as above, approx. one oz.
Actual weight of "Rosaloy" 16th Sprocket 30.25 grs.; same size in
steel weighs 102.2 grs.

Stock sizes :	15, 16, 17, 18 th.	...	3/- each.
	19, 20 th., $\frac{1}{2} \times \frac{1}{8}$...	3/6 each.

**STEEL HUB
SPROCKETS**
also suitable for
HUB UNIT

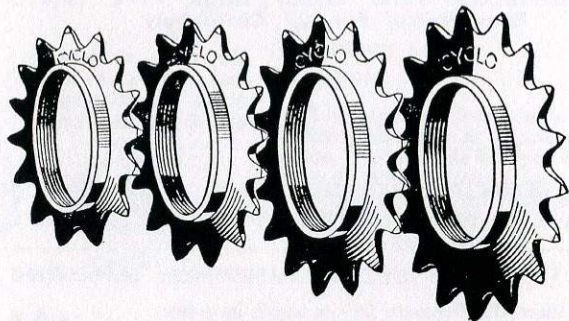

IMPORTANT.—All Cyclo Sprockets with pointed teeth are machined
to a Cyclo Form Tooth relieved to ensure the best results on the chain and
silent gear change. All sprockets are interchangeable when used on 3-speed
hub unit. A special flush sprocket can be supplied on a 4-speed unit hub
combination. Price, 2/- each.

Stock Sizes :	12, 13, 14, 15, 16, 17, 18, 19, 20, 21 th.	...	1/9 each.
	22, 23, 24, 25 th.	...	2/6 each.
	26, 28 th.	...	3/2 each.

These sprockets are also suitable for standard cycle hubs

Cyclo

SPROCKET BLOCKS
For 3 Speed Hub Conversion

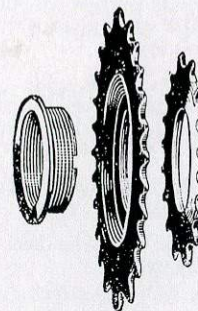

DOUBLE FIXED BLOCK
Type D S

Comprises short screwed
sleeve. Combinations
available.

Top : G.S. 13, 14, 15,
16, 17, 18 th.

Low : G.S. 16, 17, 18,
19, 20, 21, 22 th.

Price : 10/-

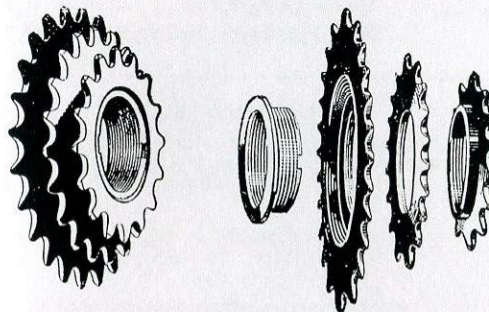

TRIPLE FIXED BLOCK
Type T/S

Comprises screwed sleeve
and three sprockets—any
combination as under:—

Top : 13, 14, 15, 16 th.

Middle : 17, 18, 19, 20,
21, 22 th.

Low : 24, 25, 26, 28 th.

Price, 15/-



Double Fixed Block Type — Splined

Top : G.S. 13, 14, 15, 16 th.

Low : 16, 17, 18, 19, 20, 21, 22 th.

Price : 10/-

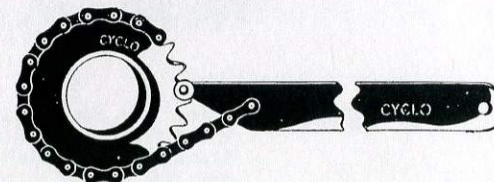
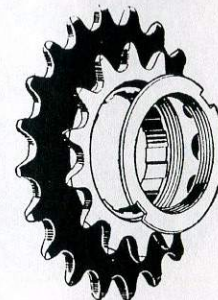

SPROCKET REMOVER

REF. 130

Will remove the most obstinate sprocket without damage to the teeth.
Price 1/9 each (less chain).

Cyclo

FREEWHEEL HUB UNIT

3 and 4-Speed "CYCLO" UNIT
for all types of Derailleur Gears

Drilling 36 or 40 holes

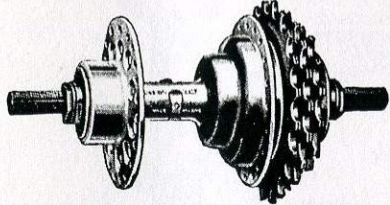

Showing complete hub F.W. assembly. Weight 18 oz.

Stock Sprocket Sizes:
12 to 26 teeth, interchangeable on
all gears.

The advantages of the "CYCLO" UNIT are apparent to anyone upon inspection:—

- 1.—Extra large pawls—pawl action and ratchet are the strongest to be found on any existing freewheel—springs easily detached.
- 2.—For cleaning and dismantling, one nut only to unscrew.
- 3.—The only freewheel giving a 12 th. sprocket.

The width over lock nuts is 4 $\frac{5}{8}$ ".

Ref. 804 3-Speed ... Price 46/3
Four-Speed type. Ref. 804A. Price 48/9

HUB UNIT BLOCK

Showing block sleeve unit 5-Speed sprocket assembly, only made in $\frac{1}{2}$ " x $3\frac{3}{32}$ " size.

Price: 20/- Set.

Also available in 4-Speed.
Price: 15/- Set.

ANY COMBINATION AVAILABLE
from 14 th. up to 23 th.

All sprockets are interchangeable

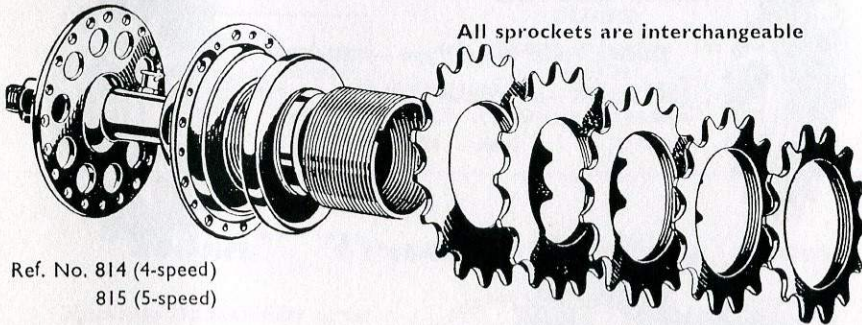

Ref. No. 814 (4-speed)
815 (5-speed)

Steel Cyclo Hubs

These hubs are preferable in all cases where the three-speed is needed. No spacing washers required—threaded to give full support to triple freewheel, chrome finish.

Drilling 36 or 40 holes

Ref. 804/B ... Price 9/6 each.

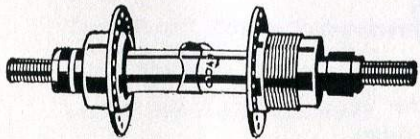

Cyclo ACCESSORIES OF OUTSTANDING MERIT

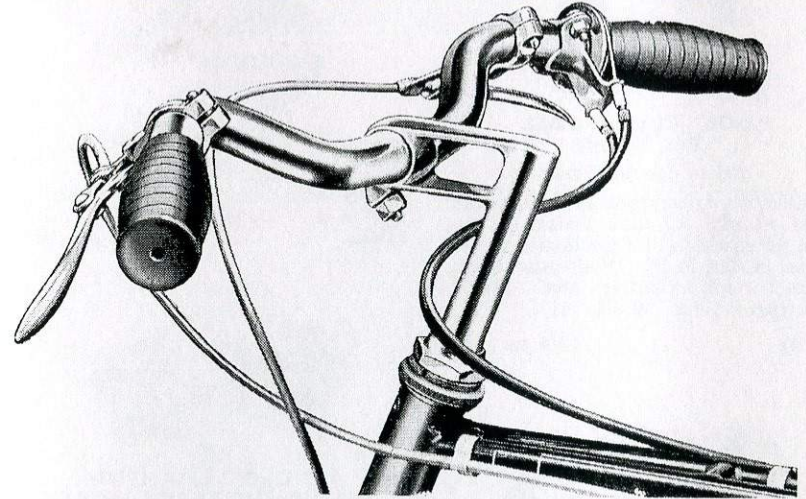

Complete handlebar assembly showing "Allrounder" Handlebars, Twist Grip, "Rosaloy" Cut-away Extension and Expander Head Locking Device

"ROSALOY"
"ALLROUNDER"
HANDLEBARS

Ref. No. 805

A popular design now available in duralumin with plugged ends gives an ideal riding position for the serious tourist. Weight, 8 ozs.

Price 12/6 per pair.

"ROSALOY"
DROP-FORGED
"NEW LOOK"
Regd. Design
STEM

Ref. 805/A

Machined entirely from a solid stamping, giving extreme lightness with extreme strength.

There's no finer extension at any price.

Price 20/- each

CYCLO
EXPANDER HEAD
LOCKING DEVICE
(Pat. appd. for)

Ref. 800

Price on application.

This simple device does away with the old-fashioned and unmechanical expander bolt liable to cause damage when fitted to light alloy stems. Gives neater appearance and weight reduction.

The expander bolt is replaced by a hexagonal lock nut which fits a 4" tapered standard fork column corresponding with a similar angle on the lock nut—a dural washer if required acts as intermediate packing washer between the hexagon lock nut and the round steering head lock nut.

Specify this latest improvement on your new machine.

FULL DETAILS OF THE TWIST GRIP CONTROL CAN BE FOUND ON PAGE FIVE.

Cyclo PEDALS Registered Designs

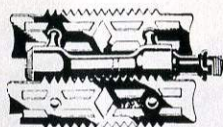

"ACE" CLUB MODEL
REF. No. 753

SOLID CENTRE PEDALS

Skilled labour employed in manufacture and assembly of these Pedals. They are the market's best production at the price in alloy Pedal. Fully guaranteed. Fitted with Chrome steel plates. Weight, 15 ozs. Width, 4 1/4".

Price 12/6 per pair.

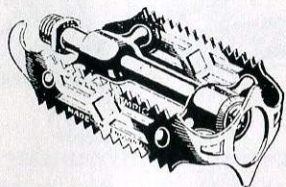

"CYCLO" OLYMPIC MODEL
REF. No. 802

A new design in alloy pedal construction. Width, 4". Weight, 17 ozs.

Price 12/6 per pair.

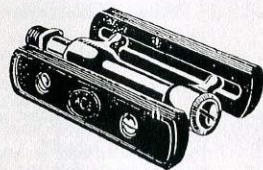

"CYCLO" RUBBER ACE
REF. No. 753/R

The Modern Lightweight Rubber Pedal fitted with detachable 4 1/4" rubber alloy inserted plates. (Pat. appd.) Weight, 23 oz.

Price 12/6 per pair.

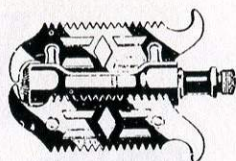

"OPPY" COURSE

REF. No. 754

Fitted with steel chrome Racing plates, 3 1/2" wide. Weight, 14 ozs.

Price 12/6 per pair.

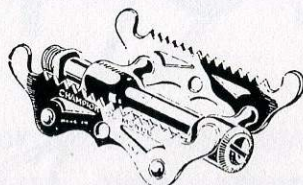

"CYCLO" CHAMPION DU MONDE TRACK MODEL

REF. No. 803

Specially designed for fast cornering. Weight, 12 ozs. Width, 3 1/4".

Price 12/6 per pair.

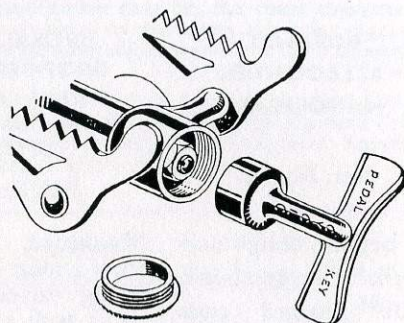

WING NUT PEDAL SPANNER

A handy tool to fit pedal spindle nut usually inaccessible with ordinary spanner. The wing part will also fit pedal cap slot.

Although designed for Cyclo pedals, will also fit most standard pedals.

Price : 1/3 each.

Cyclo GENERAL ACCESSORIES

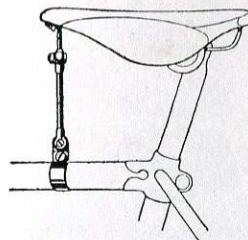

"ROSA" SADDLE SUPPORT

Regd. Design

The racing man's best friend. Will stop that saddle from moving.

REF. No. 400

Finish : Chrome. Price 2/9 each

Weight : 2 1/2 ozs. 0.070 gr.

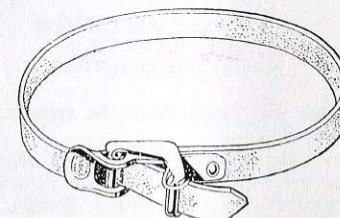

"OPPY" QUICK RELEASE
SELECTED CHROME LEATHER STRAPS
REF. No. 76

Made to meet the demand for a good quality Strap at a low price.

Price : 3/- per pair.

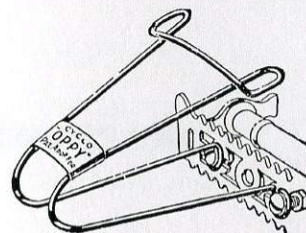

"OPPY" TOE CLIP

REF. No. 751

(Patent)

Here is a Toe Clip worthy of the very best machine, made from one piece rustless piano wire, light, strong and indestructible.... Adaptable to any machine fitted with Rat-trap pedals. The simplest and neatest Toe Clip on the market. Weight, 2 1/2 ozs. per pair.

Price 2/3 per pair.

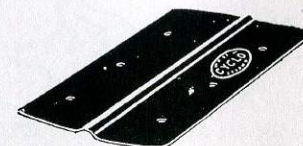

ROSALOY "OPPY" PLATES
REF. No. 752

Save wear and tear to the shoes when riding with rat-trap pedals.

Price 1/6 per pair

Also available in steel (Gun Black Finish)

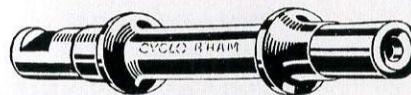

SUPER BOTTOM BRACKET AXLE

REF. No. 391

Nickel Steel.

Machined to lightest possible size. Nickel Chromed-polished end. Made in 1 1/2 C/L and G.C.C. Included in all high-class specifications.

Price : 6/- for 1 1/2" C/L

Price : 7/- G.C.C.

Cyclo GENERAL ACCESSORIES

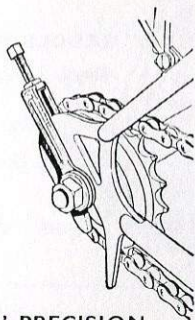

REF. No. 756

"CYCLO" PRECISION "TRUE TRACK" CHAIN ADJUSTERS

Swings clear as soon as the spindle nuts are slackened.

The only efficient device to prevent the rear wheel pulling over under pressure—keeps it in true-track always. Weight, 1 oz.

Cadmium Finish. Price ... 1/- per pair.
(Supplied in 3 doz. pairs display box.)

"ROSA" WHEEL STOPS

REG. DES. 753064

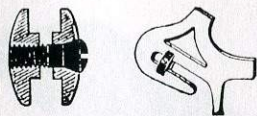

Just the thing for your "CYCLO" equipped mount. The fitting of "ROSA" Stops enables the wheel to be replaced in correct position after wheel removal. For instantaneous Chain Adjustment.

Price ... 1/2 per pair



UNIVERSAL NIPPLE KEY

REF. No. 135

The best of its type—accurately machined and hardened—a most handy little tool.
Price ... 1/6 each

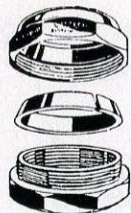

ROSALUMIN patent STEERING LOCK NUT

REF. No. 758

Made in light alloy. The perfect lock nut prevents head of cycle becoming loose under any conditions. Made to fit 1" x 24 thread column. Price ... 3/9



PEDAL SPANNER

REF. No. 150

Price ... 2/9



"CYCLO" SPANNER

REF. No. 38

To fit all requirements on "Cyclo" Gears. Price ... 9d. each



"CYCLO" BOX SPANNER

REF. No. 151

For Standard Nuts. Steel drop forged. A well machined tool.
Price ... 2/6 each

Cyclo GENERAL ACCESSORIES

CONVERSION SPINDLES

for "CYCLO" and other fitments when extra spindle length is required.



REF. No. 60. Complete Spindle as illustration, 3/3. Standard size: $\frac{3}{8}$ " x 26 thread. Length, 6 $\frac{1}{2}$ ".



REF. No. 61. Spindle with Cones only, as illustration, 2/2. Long Cones, 9d. each. Spindle only, 9d.

REF. No. 62R. Spindle and threaded packing pieces only, made for Raleigh cycles. Length, 7". $\frac{5}{16}$ " x 26 thread. Spindle and packing pieces, 2/2.

"ROSA" LOCK NUT FOR HUB SPINDLES



REF. No. 61/A.

Well made with large serrated hardened swivel washer, giving maximum grip" ping surface. . . . An efficient job, fitted if specified by all makers.

Specially recommended for "CYCLO" equipped cycles, racing machines and tandems. Finish: Dull Chrome. Standard B.S.A. size, Rear, $\frac{3}{8}$ " x 26 thread Front, $\frac{1}{16}$ " x 26 thread.

Price, 2/2 set of 4.

REF. No. 757. ROSALUMIN Wing nut. Reg. Design.

High quality drop forged light alloy wing nut fitted with large serrated hardened steel washer.

Price per pair 3/-

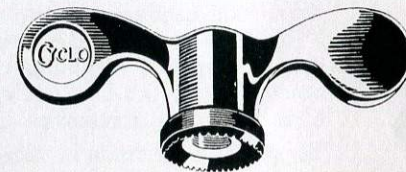

"OPPY" SERRATED WASHERS

Registered design.

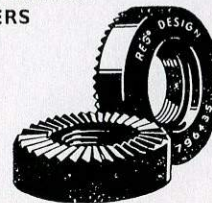

REF. No. 62

For use on drop-out fork-ends without adjusters. Specially recommended for racing men. Will stop wheel pulling over.

Specify "OPPY" Washers on your machine. Made to fit $\frac{3}{8}$ " x 26 th. standard size rear spindle; $\frac{7}{8}$ " dia. $\frac{3}{2}$ " thick. Gun Black Finish.

Price, per pair ... 10d.

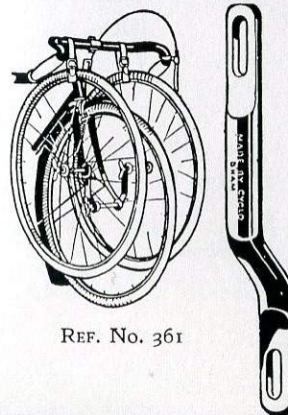

REF. No. 361

"ROSA" SPRINT WHEEL CARRIERS

Something better in Sprint Carriers for the racing man, made to the usual high standard of "CYCLO" quality. Designed to accommodate 26" or 27" wheels. Drop Forged from Duralumin. Weight, 3 ozs. per pair.

Price ... 3/6 per pair.

Cyclo "FLATPAK" BOTTLE CARRIER (Pat. appd. for)

REF. NO. 801

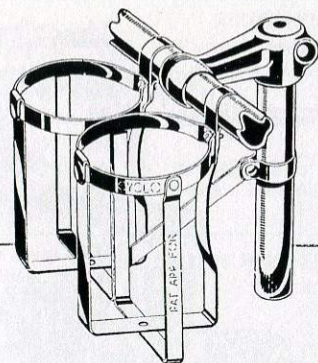

Just the thing for the speed-man and serious rider—
an ultra light, rust-proof bottle carrier designed and
produced by the leading lightweight accessory manufactur-
ers. Rigid and rattle-free when in position yet one
dozen will pack snugly into a 13" x 7½" box. Made of
"Rosaloy" to the usual exacting standards of "CYCLO"
productions and weighing only 3½ ozs., this practical
innovation meets a long felt want amongst IMPORTERS
of British made accessories and the Trade in general.

Supplied to the trade in dozen lots as illustrated.

Price 6/- per pair

REF. NO. 801A

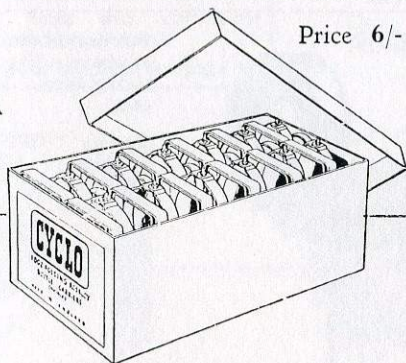

IDEAL FOR
EXPORT
PACKING

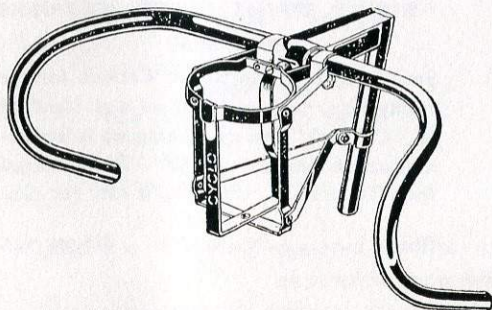

REF. NO. 801B

Single type adaption
of above.

Price 4/-

Cyclo THE "ROSA" SWINGING CRANK

PRICE OF ALL
MODELS

Retail £1/12/-

LESS PEDAL.

REF. No. 66/S.

For Left or Right Side. Only
suitable for rider with slight or
partial knee action.

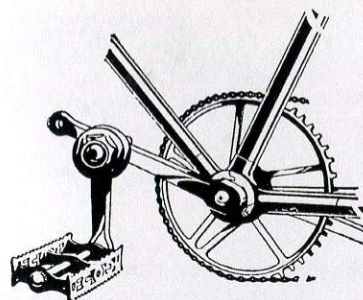

REF. No. 66/A/L

This type is for left hand fitting direct with
existing bracket axle, and is suitable for either
a short leg, a stiff limb, or an artificial leg
without movement above the knee.

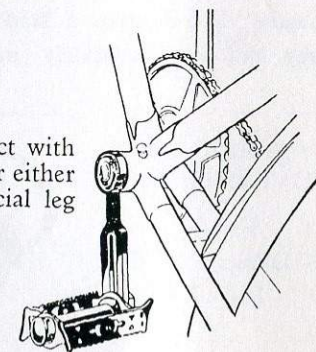

REF. No. 66/A/R

This type is for fitting on chain wheel side,
and requires to be used in conjunction with
our special axle Ref. R. This type enables
the drive to be carried by the left leg, whilst
the right leg remains stationary.

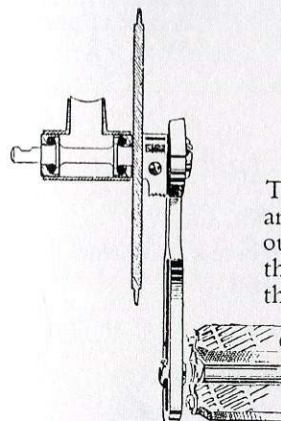

IMPORTANT. When ordering, please give the following information:—

- (1) State Ref. No. of type required.
- (2) State if required for *right* or *left* leg.
- (3) Is limb entirely stiff, or has it partial movement?



The Special axle is not required for Left Hand.

REF. No. R. Special Axle for R.H. 5/- Retail
Axle made to special size 10/- "

*N.B.—When ordering, please send existing bracket axle or sketch with
measurements to enable us to send the correct type.*

Cyclo JUVENILE ACCESSORIES

JUVENILE PEDALS

REGD. DESIGN

Light and sturdy, these pedals are ideal fitments for every child's tricycle or miniature bike. Fitted with broad plates to avoid heavy wear on shoes.

REF. J/3 Price 5/- per pair.

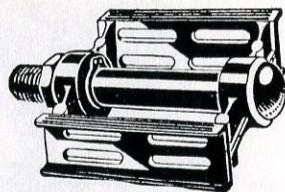

Rosaloy Pedals have a standard finish of high class chromatic silver grey and are accurately machined to standard C.E.I. thread and size.

" ROSALOY " JUVENILE BELL

REF. J/5

2" Dome, 5/8" Clip.

Price 2/-

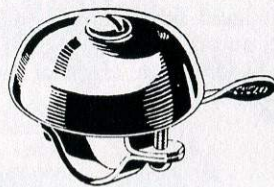

" ROSALOY " RACING BELL

With 7/8" or 15/16" Clip—
The Racing Man's Favourite—only weighs 1 1/2 oz.
Price 2/-



JUVENILE FREEWHEEL

REF. No. J/4

14 th. x 1/8" 31/32" bore x 20 Thread.

Price 3/-

STANDARD MANUFACTURERS FITTINGS



Ref. 23/P

REF. 23/P

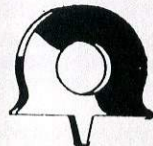

Ref. 24/P

REF. 24/P

Reg. Design Mud-guard Eyes, Peg type

Reg. Design Reflector eyes—also suitable as braze-on fitting for Cyclo Tension Spring.



Ref. T/E

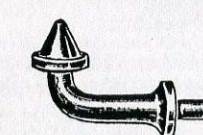

Ref. 25

REF. T/E

REF. 25

REF. 25/C

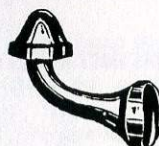

Ref. 25/C

" Cyclo " Detachable and Adjustable Braze-on Bracket.

Braze-on Pump Pegs, Peg Type.

„ Concave type.

PRICES ON APPLICATION

Cyclo STANDARD CYCLE PARTS

FRONT HUB CUP

REF. CODE SCP/C1

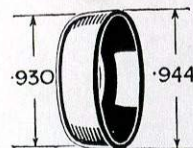

Made from precision steel pressing, machined and hardened.

Approx. weight per gross :
Kg. 1.300—2 lbs. 14 ozs.

FRONT HUB CUP

REF. CODE SCP/C3

Made from the bar to the definite standard size of .937" unless otherwise specified.

Approx. weight per gross :
1 Kg. 400 — 1 lb. 1 oz.

Finish : Self Colour—Hardened.

STANDARD DROP FORGED CHAIN ADJUSTER

REF. CODE SCP/A1

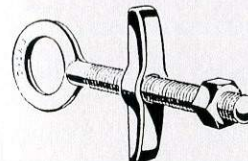

Complete with 1" cap and nut.

Approx. weight per gross single :
Kg. 1.952 — 4 lbs. 5 ozs.

Finish : Cadmium.

CRANK COTTER

REF. CODE SCP/74

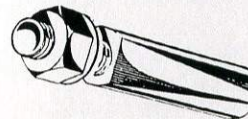

Standard size 3/8"—9.5 m.m.

Finish : Cadmium.

Complete with washer and nut.

Approx. weight per gross :
3.500 Gr. — 7 lbs. 8 ozs.

PRICES AND SAMPLES ON APPLICATION

REAR HUB CUP

REF. CODE SCP/C2

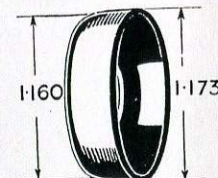

Made from precision steel pressing, machined and hardened.

Taper fit as per sizes shown.

Approx. weight per gross :
2 Kgs. — 4 lbs. gross.
Finish : Self Colour.

REAR HUB CUP

REF. CODE SCP/C4

Made from the bar to the definite standard size of 1.156" unless otherwise specified.

Approx. weight per gross :
4 Kgs. — 6 lbs. 8 ozs.
Finish : Self-Colour—Hardened.

DURALUMIN CALIPER BRAKE SHOE

REF. CODE SCP/BS1



Fitted with Fibrax No. 275 block. Complete with pin and nut as illustrated. Suitable for all standard types caliper brakes.

STANDARD STEEL BRAKE SHOE

REF. CODE SCP/BS2



Complete with Pins, Nuts, Washers and Blocks.

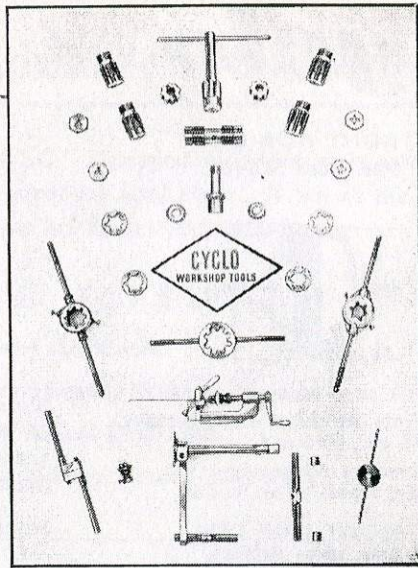

FOR "CYCLO" TOOLS FOR
THE CYCLE WORKSHOP
SEE SPECIAL TOOL
CATALOGUE ISSUED TO
TRADE ONLY.

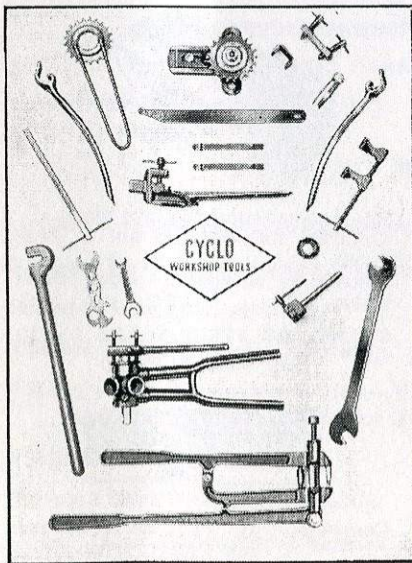

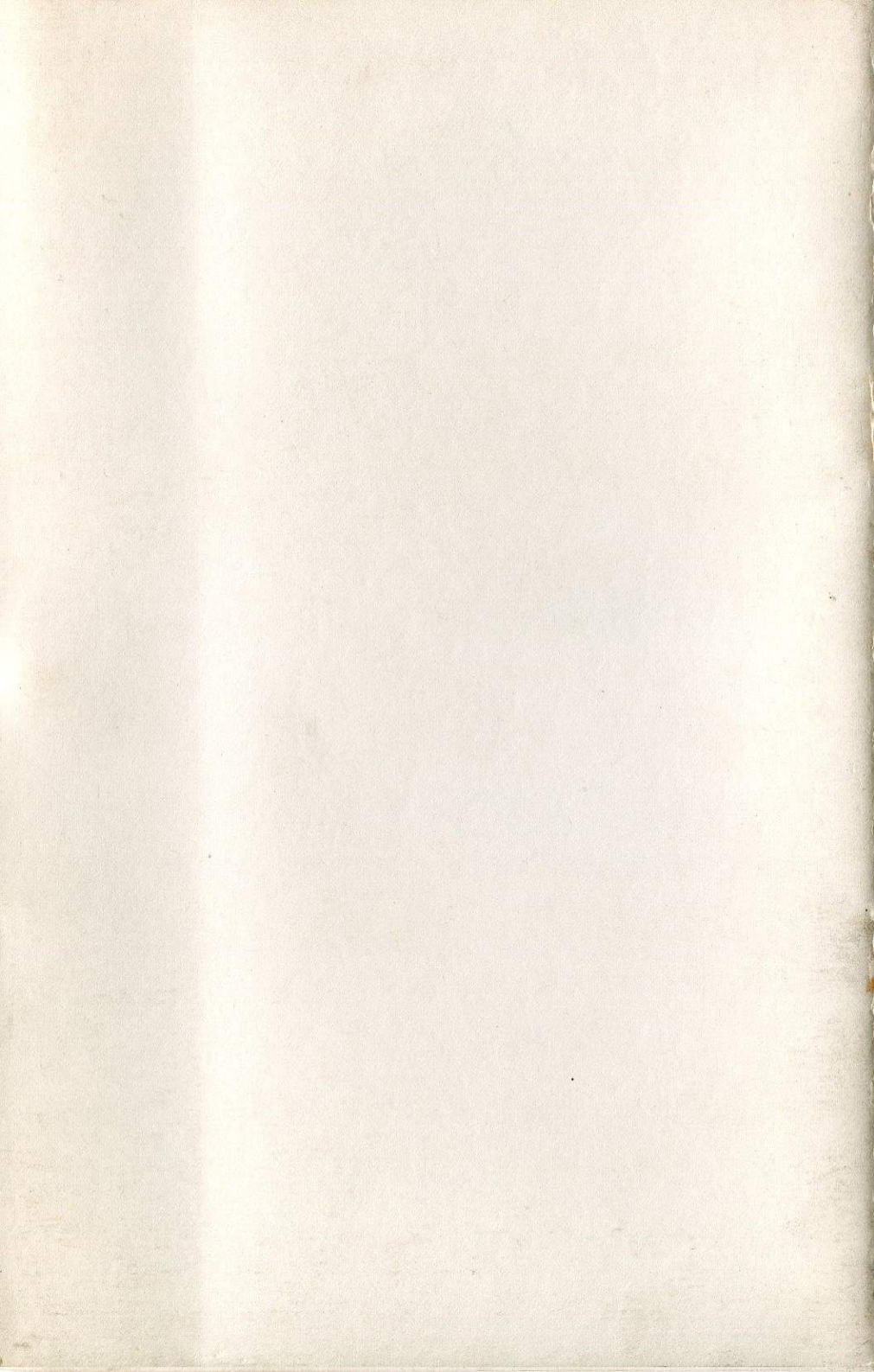

IceniCAM Information Service

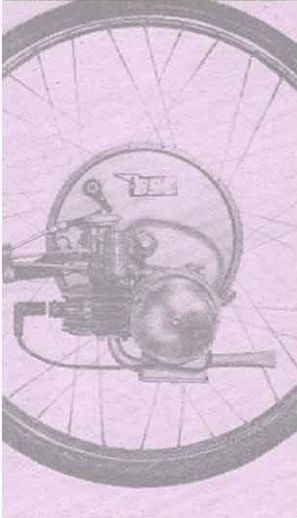
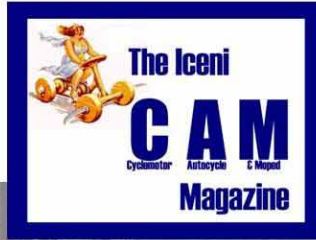

www.icenicam.org.uk