

**THE  
CYCLEMOTOR  
MANUAL**



THE  
CYCLEMOTOR  
MANUAL

Copyright 1914 by  
The Cyclemotor Corporation  
New York, N. Y.  
Printed in the United States of America  
All rights reserved

THE CYCLEMOTOR CORPORATION

NEW YORK, N. Y.

11  
\$  
EE  
1914

*Also published in association with*  
"MOTOR CYCLING"

"MOTOR CYCLING" MANUAL  
"MOTOR CYCLING" ROAD TESTS  
MODERN MOTORCYCLE MAINTENANCE  
"MOTOR CYCLING" ELECTRICAL MANUAL  
"MOTOR CYCLING" YEAR BOOK  
LIGHTWEIGHT MOTORCYCLES  
TUNING FOR SPEED  
MOTORCYCLE ENGINEERING FOR SCHOOLS

# THE CYCLEMOTOR MANUAL

COMPILED BY THE STAFF OF

*MOTOR CYCLING*



TEMPLE PRESS LIMITED  
BOWLING GREEN LANE  
LONDON, E.C.1

FIRST PUBLISHED 1952  
SECOND EDITION 1955

CYCLEMOTOR  
MANUAL

CONTROLLED BY THE STATE OF

Motor Cycle



*Printed by Purnell and Sons Limited  
Paulton (Somerset) and London*

MADE IN GREAT BRITAIN

## CONTENTS

FOREWORD	vii
<i>Part One—General Section</i>	
I "Do I Want a Cyclemotor?"	3
II Types of Cyclemotor	6
III General Principles	11
IV "The Law Requires . . ."	24
V Riding a Motor-assisted Bicycle	28
VI Maintaining Your Machine	33
VII If It Stops . . .	47
<i>Part Two—Friction-drive Cyclemotors; Positive-drive Cyclemotors; Mo-peds</i>	
VIII Friction-drive Cyclemotors	57
IX Positive-drive Cyclemotors	82
X Mo-peds	101
TECHNICAL APPENDIX	118
INDEX	122

## FOREWORD

SINCE the first edition of this handbook appeared in the winter of 1952, there have been many developments in the sphere of personal, ultra-lightweight transport. Undoubtedly the most important has been the growing popularity of the light autocycle—called, for want of a better word, by its German appellation of “mo-ped”. It is thus particularly appropriate that the section of the book dealing with such machines has been extended to include all those now commonly in use on British roads.

In company with their elder brothers—the cyclemotors—these machines are extending the post-war revolution which is converting thousands of erstwhile cyclists and pedestrians into motorists. They have discovered—and others are still discovering, at the rate of thousands every week—that besides offering economy, and the independence which the possession of one’s own vehicle confers, these small-capacity machines have a charm of their own. With a good turn of speed and adequate hill-climbing ability, they are as easy to handle as a pedal bicycle; create no garaging problems; and probably cost less to run than the price of the shoe-leather they save. Furthermore, they are highly reliable.

But it is always advisable to know one’s vehicle—and that is where this book comes in. Within its covers will be found all the information which the average cyclemotorist needs to know—basic principles; types of unit; legal requirements; maintaining and riding; preparing a cycle for motorising and—for the occasional luckless one—a complete chapter on diagnosing faults. Additionally, elementary maintenance procedure for all the most popular units is given in a well-illustrated detail section.

Whether you are a novice, just contemplating the purchase of a cyclemotor, or an experienced road-user already, we hope that this book will help you to resolve any queries you may have. And if you feel that you need more assistance, the staff of *Motor Cycling* are at your service . . . you need only write to us at Bowling Green Lane, London E.C.1, or phone TERminus 3636 and we shall do our best to help you.

R. R. HOLLIDAY  
Editor of “*Motor Cycling*”

## FOREWORD

Since the first edition of this handbook appeared in the winter of 1952, there have been many developments in the sphere of personal, ultra-light-weight transport. Undoubtedly the most important has been the growing popularity of the light aircraft—called for want of a better word, by its German appellation of "motor". It is less unambiguously appropriate that the section of the book dealing with such machines has been extended to include all those now commonly known as "light aircraft".

In company with their elder brothers—the conventional—these machines are extending the post-war revolution which is converting the elements of everyday existence into products into products. They have discovered—and others are still discovering—at the rate of about one every week—that better, efficient economy and the independence which the possession of one's own vehicle confers. These small-capacity machines have a claim of their own. With a good deal of speed and adequate hill-climbing ability, they are easy to handle as a pedal bicycle, create no running problems; and probably cost less to run than the price of the bicycle itself. In any case, I think you will be highly satisfied.

It is always advisable to know one's vehicle—and that is what this book aims at. Within its covers will be found all the information which the average cyclist needs to know—basic principles, types of main, legal requirements, maintenance and repair, preparing a cycle for motorway and for the open road, looking into—a complete chapter on designing built. Additionally, elements of maintenance procedures for all the most popular models is given in a well-illustrated detail section.

Whether you are a novice, just commencing the purchase of a motor, or an experienced road-racer already, we hope that this book will help you to resolve any queries you may have. And if you feel that you need more assistance, the Editor of Motor Cycling, is at your service. . . . you need only write to us at Bowling Green Lane, London E.C.1, or phone TERMINUS 3630 and we shall do our best to help you.

R. K. HARVEY

Editor of "Motor Cycling"

## PART ONE

### GENERAL SECTION

PART ONE

GENERAL SECTION

CHAPTER I

“DO I WANT A CYCLEMOTOR?”

WHILE THE cyclemotor in its modern form came into being for the benefit of that enormous army of cyclists who pedal merely because they have to, its appeal has spread far beyond that group in the few years since really practicable units first became available in this country.

The cyclemotor originated, of course, on the Continent, where many thousands have been in daily use for years past. In almost any continental town, one can see literally hundreds of motor-assisted bicycles, their riders ranging from shopkeepers and elderly ladies to youths and parish priests. Anyone, in fact, who has a series of daily journeys to perform or who is not athletic enough to ride bicycles for longish distances or under adverse conditions, buys a cyclemotor. A further factor, of course, is that in most continental countries these little units are free of road tax—an enlightened view not yet adopted by the authorities here, but one which is being vigorously pressed upon them.

What appeal the cyclemotor makes to you will depend, largely, upon the use to which you would put it. In a few years, it has wrought almost a social revolution on this side of the Channel by putting personal mechanical transport within the grasp of all for the first time.

The ride-to-work-and-back cyclist will be attracted by the cyclemotor's economy. Most units will propel a cycle and a rider of 12 stone or so 250 miles on a gallon of petrol-oil mixture costing roughly five shillings—less than one farthing per mile. No longer need he risk indigestion by pedalling quickly home to a “bolted” lunch and then rushing back to work—the cyclemotor alters all that! With a sustained speed of anything up to 20 m.p.h. on the level and its pulling power on hills, it straightens-out the gradients and takes the sting out of that stretch of open road where, previously, one could



have sworn that a half-gale always blew into one's face. So, the cyclemotorist reaches his work fresh for the day's tasks and returns home ready and able to enjoy his spare time.

Housewives, too, find the cyclemotor a boon. Emancipated from bus queues—and fares!—Mrs. Everyman is able to ride in comfort to the shops, make purchases at her leisure and still reach home again in good time to prepare the mid-day meal.

Commercial users are turning to this most economical form of transport for the convenience of their customers. In these days a delivery van is expensive to run and not an economic proposition where small deliveries are concerned. The shop-keeper finds that a lad on a motor-assisted delivery bicycle enables him to maintain a "to-your-door" service at a fraction of the cost, in terms of upkeep and running expenses, of even the cheapest of vans. Yet again, in town traffic, the powered cycle can reach its destination just as quickly as the van.

So much for the utility aspects, although you will doubtless be able to think of many other tasks to which these little motors may be applied. We must not, however, overlook their recreational value.

Riders who normally toured on a pedal bicycle and who now have an engine fitted, have discovered just how much they previously missed. Not surprisingly, either, for when one has to concentrate one's energy on pedalling one has but little chance to sit back and admire the scenery. The cyclemotorist, on the other hand, can "free-wheel" slowly through the countryside, relaxed and fresh, able to enjoy every minute of his ride. And, should he come upon one of those uninteresting stretches which will invariably appear during the best of tours, he can open the throttle and head quickly for more attractive parts. His range, too, is extended. Where weekend runs were previously limited by considerations of time and distance, the cyclemotor is the key which unlocks the door to fresh country and new adventure.

Not the least to benefit is the impecunious family man, with his wife on the tandem's rear seat and his child in a

miniature sidecar. He finds that appealing routes which previously were ruled out by reason of laborious hills or intervening miles are now within his reach.

It might justifiably be supposed that one would at first have a heavy capital outlay for an attachment offering all these advantages. This, however, is not so, for it is possible to buy a cyclemotor for less than £20, while few cost more than £35. With the added advantages of low fuel consumption and running costs—these should not amount to more than £5 or so annually, even with an allowance made for replacements such as tyres, etc.—a cyclemotor easily pays for itself within a few years.

"Do I want a cyclemotor?" That is a question you must answer for yourself. Remember, though, that no other form of personal transport can offer so many advantages for so little outlay and attention.

## TYPES OF CYCLEMOTOR

HAVING DECIDED upon the purchase of a cyclemotor, the next step is to choose between the dozen or so different types of unit which are at present available.

The most popular—numerically speaking—is the friction-drive type, in which the power is transmitted by an emery-faced or a milled roller, driven by the engine, and held in direct contact with either the front or rear tyre by means of a spring or a mechanical locking device. This does not produce the evil effects upon the tyre which one might, at first glance, suppose—in practice the increase in tyre wear has been found to be almost negligible. It can be reduced still further by employing, on the driven wheel, one of the specially-strengthened cyclemotor tyres developed by several of the leading tyre companies, or even by using heavyweight bicycle tyres, such as those commonly fitted to tandems.

With the exception of one imported engine, all the units marketed today operate on what is known as the two-stroke cycle—a subject which we will examine in greater detail at a later stage. It suffices to say, at present, that these are the simplest internal-combustion engines, employing only three moving parts.

**Front-wheel-drive Engines**

One of the earliest British-designed units, the 49 c.c. "Mocyc" is mounted on an exceptionally sturdy tubular frame which is attached, at its upper end, to handlebar clamps and, at the lower extremity, to the wheel spindle. It is obtainable separately, as a true cyclemotor, or in combination with a Cairns bicycle. The drive is transmitted to the front wheel—an arrangement which, once highly popular, is now represented solely by this unit.

Previous f-w-d. engines, second-hand examples of which may still be bought, include the 32 c.c. Berini, 45 c.c. Cymota and an early version of the Itom.

**Rear-wheel-drive Engines**

Three units—two imported, the other a British production—are specially designed to fit below the bottom bracket of the bicycle and to drive the rear wheel.

The British engine is the Vincent "Firefly"—a horizontal 48 c.c. unit which has a gear-driven roller. This latter component, by the use of an ingenious system whereby a rubber sleeve is "bonded" between an inner shaft and the steel outer roller, also acts as a shock absorber. The roller is brought into contact with the tyre by a cable-operated mechanism.

Hailing from Italy, the 38.5 c.c. "Mosquito" is also a horizontal unit, employing a gear-driven roller. The system of roller engagement is, however, somewhat different, the unit being spring-loaded onto the wheel. Completing the trio is the Itom—likewise an Italian product—which is of 48 c.c. It is unusual in having foot-controlled engagement.

The remaining engines in this class are all mounted above the rear wheel, behind the bicycle seat stays. Probably the best-known of all British cyclemotors, and certainly the first in the field, the "Mini-Motor" is based on an Italian design. With a horizontal cylinder of 49.9 c.c., it has a grooved roller and is spring-loaded onto the tyre. It is fixed to a tubular lug clipped to the bicycle seat-pillar at its forward end and to a special fork, anchored on the wheel spindle, at the rear.

An all-British design, the 49 c.c. "Power-Pak" has an inverted cylinder, and is rubber mounted to obviate vibration. This unit has positive-engagement by means of a lever mounted on the left-hand side, and also incorporates a lifting handle—useful if the machine to which it is fitted must, as is often the case, be lifted up steps into a passage-way. The ingenious "Synchromatic Drive" model has a coupled throttle and clutch—a device which considerably simplifies traffic driving.

### Positive-drive Engines

So much for those units which drive by friction. Let us now consider the range of cyclemotors which employ some positive form of transmission, such as a chain, a belt or a train of gears.

Unusual in every aspect, the Ducati 48 "Cucciolo"—the name means "Little Puppy-dog"—is radically different from all the units so far described in that it utilises the four-stroke principle. Without going into unnecessary detail at this stage, this means that the engine fires only once in two revolutions of the crankshaft, instead of once every revolution as is the case with the two-stroke. The relative advantages of the two types can safely be left until a later chapter. Each has its own particular qualities and both types of engine are extensively employed in the motorcycle field.

A further feature of the Ducati is that it incorporates a two-speed gearbox and a multi-plate clutch. The drive is taken through the bicycle's own pedalling chain, a special crank set which incorporates a free-wheel device being supplied with the engine. The unit is fitted below the bottom bracket, where it is secured by clamps. Naturally, this unit is relatively expensive, the price—nearly £50—being almost twice that of the simpler types.

Belt drive is employed on the 31 c.c. "Cyclaid". Although long since discarded in the motorcycle sphere, this form of transmission is eminently suitable for adaption to cyclemotors, being—literally—its own shock-absorber. This unit, carried above the rear wheel on special fittings which embody a rubber mounting at the front and a spring fixing at the rear, has a gear drive to the engine pulley. The rear-wheel pulley is clamped to the spokes and the driving belt itself is of rubberised material.

Fitted within the large hub of a special rear wheel, the 32 c.c. "Cyclemaster" has achieved great popularity. The engine itself is carried on a mounting on the spindle, being anchored to the chain stay by an arm and a clamp. The drive is in two parts—an internal chain drive to a simple clutch

and an external driving sprocket, and a short chain thence to the large, final drive sprocket, which is fitted on the inside of the massive hub casing. The engine has a simple form of rotary valve, and a coaster brake is contained in the inner hub. Earlier models are of 25.7 c.c. capacity.

Developed by one of Britain's biggest industrial concerns, the B.S.A. "Winged Wheel" has gained a considerable degree of popularity. An outstanding feature of this 35 c.c. "in-the-wheel" unit is the provision of a built-in large-diameter brake.

Two other positive-drive engines, which are no longer available, were both of 40 c.c.—the British "Bantamoto" and the French V.A.P. Each was designed to fit alongside the rear wheel on a special spindle extension but, whereas the former was a gear-drive unit, the latter specified a chain.

In addition to the simple engine units, there are several machines on the market which can be purchased complete with engine. While not actually cyclemotors—indeed, they are generally called by the German name of "mo-peds"—they offer cyclemotor performance and economy coupled with the durability of bicycle parts specially designed to withstand the stresses of mechanical propulsion. These machines, the most notable of which are the Motobécane "Mobylette", N.S.U. "Quickly", Phillips, "VeloSolex", and Zündapp "Combinette", are fully described in Chapter X of this book.

The "Cyclemate", a machine powered by what is basically the famous "Cyclemaster" engine, was introduced late in 1954. Maintenance of this machine should follow the principles laid down in the general section, in conjunction with the detailed "gen" on the "Cyclemaster" to be found in Part Two.

There, then, is the field from which the intending purchaser may choose. The factors that will guide his choice are many and varied. Price, of course, will probably be the major consideration. The average cost of these engines is in the region of £25, although the cheapest can be obtained for several pounds less.

Whichever unit is eventually purchased, one thing is certain.

Properly treated it will give utterly reliable and economical service. But, to ensure that such service is obtained, it is necessary to understand the working of the engine and to be able to carry out simple routine maintenance. By giving attention to the upkeep of the engine—attention which, incidentally, probably takes no more than five minutes a day—the enjoyment of running one's own personal transport at minimum cost can be fully realised. In the following chapters we shall examine these subjects—first the general principles, and then the application of those principles to most of the individual engines which have been mentioned here.

## GENERAL PRINCIPLES

ALTHOUGH THE overwhelming majority of cyclemotors operate on the two-stroke principle, it is better to examine first the operation of a four-stroke engine. It should be borne in mind that, in the four-stroke engine, only one operation takes place at a time, whereas in the two-stroke there are always two things happening at once. When the operation of a four-stroke has been mastered, the two-stroke principle will easily be understood.

### Engine Components

Initially, however, we must have a general idea of the structure of an engine. Externally it consists of a light-alloy case, on which is mounted a cylinder, this having large ribs—"fins" is the technical term for them—which help the engine to rid itself of excess heat. This cylinder has a lid, which is properly termed the "cylinder head". The internals consist of a pair of flywheels or a crank, running on bearings, contained in the alloy case—which is consequently termed the "crankcase"—and a connecting rod fitted to the piston. The piston has several spring-steel rings—carried in grooves—to ensure a gas-tight seal in the cylinder, in which it is a sliding fit.

### The Four-stroke Engine

These components are all common both to the four-stroke and to the two-stroke engine. The four-stroke cylinder head, however, differs from that of the two-stroke in that it is equipped with passages, normally termed "ports", through which fresh petrol-air mixture may be induced and burnt gas dispelled.

Obviously, the engine could not work if these ports remained open all the time and they are, therefore, closed by mush-

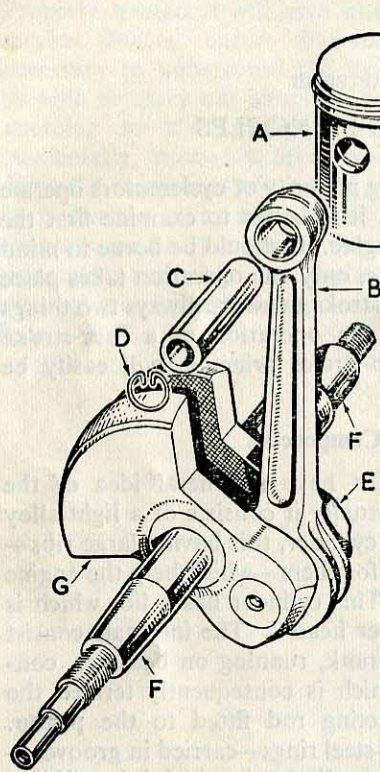

The three moving parts of a two-stroke engine are A, the piston, B, connecting rod, and F, the crankshaft. A pressed-in pin joins the crank webs at E, forming the big-end bearing which is balanced by bob-weights, G. At the top, or little, end of the connecting rod the piston pivots on a gudgeon pin, C, and is retained in position by the circlips, D.

room-shaped valves, spring-loaded into place. At the correct moments, these valves are pushed open by a system of rods and levers, actuated by means of a cam.

Assume that we are about to start a four-stroke engine. As we pedal away, the crankshaft of the engine starts to turn and the piston moves down the cylinder. As it does so, the valve which has been closing the inlet port is pushed off its seating and the pressure of the atmosphere literally propels a charge through the carburetter—a special device for mixing air and petrol in the correct proportions (14 parts of air to

OPERATION OF THE FOUR-STROKE PETROL ENGINE

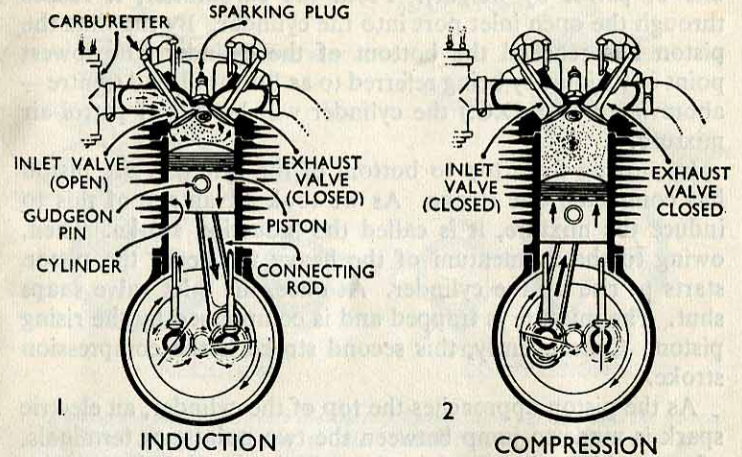

1. INDUCTION  
As the piston descends a charge is drawn in through the open inlet valve.

2. COMPRESSION  
The piston rises and compresses the charge. Both valves are closed.

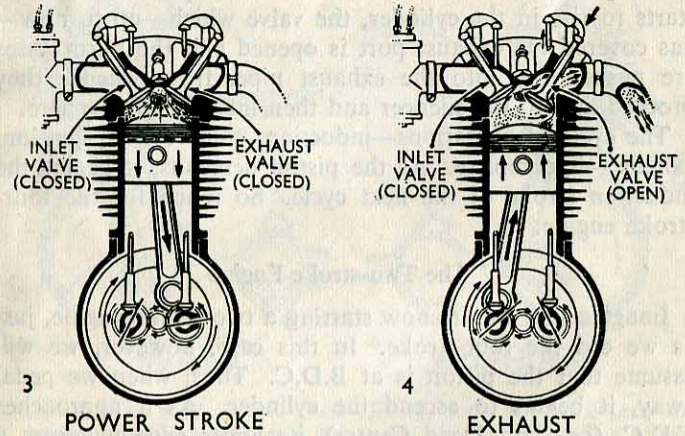

3. POWER STROKE  
The compressed charge is fired by an electric spark, the valves remaining closed.

4. EXHAUST  
The piston rises; the burnt gases pass out through the exhaust port, which is now open.

one of petrol by weight). From the carburetter, it rushes through the open inlet port into the cylinder. By the time the piston has reached the bottom of the cylinder (the lowest point of its journey being referred to as Bottom Dead Centre—abbreviated to B.D.C.) the cylinder will be full of petrol-air mixture.

In moving from top to bottom of the cylinder, the piston has completed one stroke. As we took advantage of this to induce the mixture, it is called the induction stroke. Then, owing to the momentum of the heavy flywheels, the piston starts to rise up the cylinder. At once, the inlet valve snaps shut. The mixture is trapped and is compressed by the rising piston. Consequently, this second stroke is the compression stroke.

As the piston approaches the top of the cylinder, an electric spark is made to jump between the two points, or terminals, of a sparking plug fixed in the cylinder head. The mixture is ignited and expands, pushing the piston downwards to begin the third—or ignition—stroke which, of course, provides the power.

Lastly comes the exhaust stroke. As the piston once more starts to rise in the cylinder, the valve which—up to now—has covered the exhaust port is opened and the burnt gases are pushed out into the exhaust pipe, from whence they proceed first to the silencer and then into the atmosphere.

The cycle of operations—induction, compression, ignition, exhaust—is complete. As the piston descends, it begins the induction stroke of the next cycle. So much for the four-stroke engine.

### The Two-stroke Engine

Imagine that we are now starting a two-stroke engine, just as we did the four-stroke. In this case, however, we will assume that the piston is at B.D.C. Thus, when we pedal away, it begins to ascend the cylinder. As it approaches T.D.C. (i.e. Top Dead Centre), its lower edge uncovers a hole—a port, in fact—cut into the cylinder wall. This port connects with the carburetter and—as was the case with the

### FOUR PHASES OF MODERN TWO-STROKE OPERATION

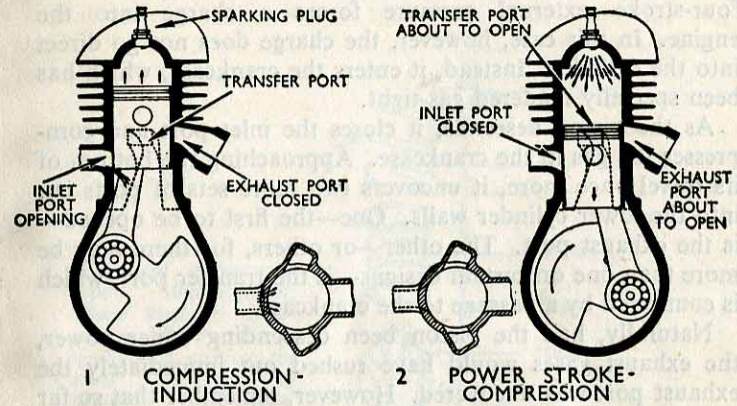

*Rising, the piston uncovers the inlet port to admit fresh gas to the crankcase, at the same time compressing the mixture in the cylinder.*

*Combustion drives down the piston which, sealing all ports, also compresses gas in the crankcase.*

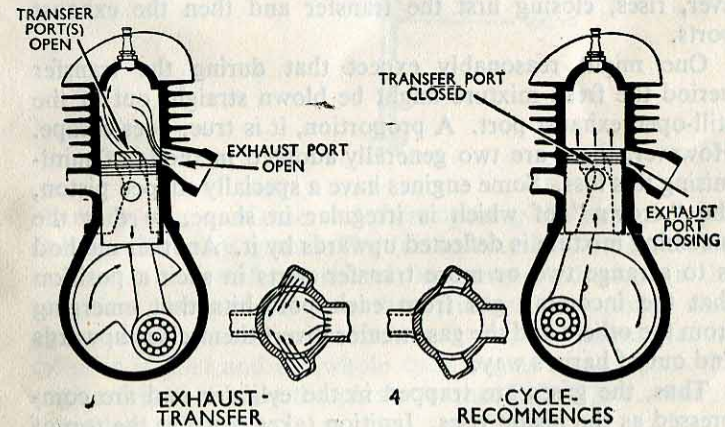

*At bottom dead centre, both transfer and exhaust ports are open. The position and angle of the ports ensures that no undue amount of fresh mixture is lost.*

*Rising, the piston again seals all ports and the compression of the new charge of gas commences.*

four-stroke—external pressure forces a charge into the engine. In this case, however, the charge does not go direct into the cylinder. Instead, it enters the crankcase, which has been specially rendered gas-tight.

As the piston descends, it closes the inlet port and compresses the gas in the crankcase. Approaching the bottom of its travel once more, it uncovers two more sets of ports cut into the lower cylinder walls. One—the first to be opened—is the exhaust port. The other—or others, for there may be more than one on certain designs—is the transfer port, which is connected by a passage to the crankcase.

Naturally, had the piston been descending under power, the exhaust gases would have rushed out immediately the exhaust port was uncovered. However, remember that so far we have only induced the mixture into the crankcase and that consequently no “explosion” has occurred.

Immediately the transfer port begins to open, the gases which have hitherto been trapped in the crankcase see a hope of escape and rush into the cylinder. The piston, however, rises, closing first the transfer and then the exhaust ports.

One might reasonably expect that during the transfer period the fresh mixture might be blown straight out of the still-open exhaust port. A proportion, it is true, does escape. However, there are two generally adopted methods of minimizing this loss. Some engines have a specially shaped piston, the “crown” of which is irregular in shape, so that the incoming mixture is deflected upwards by it. Another method is to arrange two or more transfer ports in such a position that the incoming gas from each port hits that emerging from the others and the gas streams divert themselves upwards and out of harm's way.

Thus, the gases are trapped in the cylinder and are compressed as the piston rises. Ignition takes place at the top of the stroke, as in the four-stroke engine, and the piston is driven down the cylinder. While at the top, however, it uncovers the inlet port and thus a fresh charge is drawn into the crankcase. The piston descends, compressing this fresh

*A typical motorcycle-type decompressor. Those used on cycle-motors differ only in detail and employ the same principles of operation and construction.*

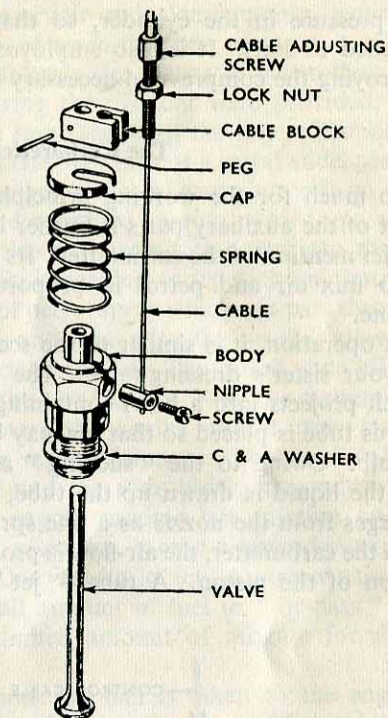

charge in the crankcase and then opening the exhaust port. Out go the burnt gases. The piston travels a little further, uncovers the transfer port and the compressed gases in the crankcase are pumped into the cylinder. The piston rises again, more mixture enters the crankcase, the mixture in the cylinder is fired and the whole cycle begins anew. Thus the engine fires each time the piston reaches T.D.C., i.e. once in every two strokes.

An important fitment on two-stroke engines of the “clutchless” type is the decompressor. This is actually a small mushroom valve but, instead of being operated automatically, it is controlled directly by the rider. Its purpose is to release

the pressure in the cylinder, so that the machine may be pedalled to start. It is also employed to stop the engine by destroying the compression necessary for firing the mixture.

### The Carburetter

So much for the working principles of the engine. Now what of the auxiliary parts? Earlier in this chapter we made a brief mention of the carburetter. Its purpose, you will recall, is to mix air and petrol in proportions acceptable to the engine.

In operation, it is similar to the scent-spray on your wife's or your sister's dressing-table. The scent-spray has a tube which projects into a bowl containing scent. The upper end of this tube is placed so that air may be pumped over it from a bulb. Owing to the "sucking" action of the stream of air, the liquid is drawn up the tube, mixes with the air and emerges from the nozzle as a fine spray.

In the carburetter, the air-flow is provided by the "sucking" action of the piston. A tube—"jet" is the correct term—

projects into a petrol reservoir and, consequently, petrol is drawn up into the stream of air in the form of spray.

Obviously, however, unless some means of controlling the amount of mixture entering the cylinder were provided, the engine would run at the same speed all the time. Therefore, a throttle is fitted. This takes the form of a metal slide, placed above the jet, one of its edges being cut away in the form of a half-moon to allow a predetermined amount of air to pass for starting. Fixed to the slide and extending down into the jet is a tapered needle. This, according to its position, restricts or increases the amount of petrol spray which can pass through the jet. Raise the slide and you raise the needle, allowing more petrol to pass through the jet. The raised slide allows more air into the main tube—or "choke"—of the carburetter. Thus, more mixture enters the engine and it runs faster. Lower the slide and the reverse happens. The needle shuts off the supply of petrol and the slide blocks the passage of the air. Therefore the engine receives less mixture and it runs more slowly. That, of course, is only a general picture—there are other factors. One is the pilot jet—a narrow passageway which allows a small amount of fuel to "by-pass" the main jet, providing a limited amount of mixture for slow-running.

We have now seen how the fuel is taken to the engine. First, however, it must reach the carburetter. Obviously, the supply must be controlled, otherwise the petrol would just force its way past the jet and all our careful metering of the flow would have been wasted. This is achieved by adding to the carburetter a separate petrol reservoir called a "float-chamber". As its name implies, this contains a float and it works in a manner very similar to the household cistern. Petrol flows into the chamber and the float naturally rises. Integral with the float is a tapered needle which gradually blocks the fuel feed. When the petrol has reached the desired level, the float needle fully closes the system. As soon as enough petrol has been used, the float drops slightly and the needle re-opens the fuel feed until the correct level has again been reached. Usually, this float chamber is attached to the

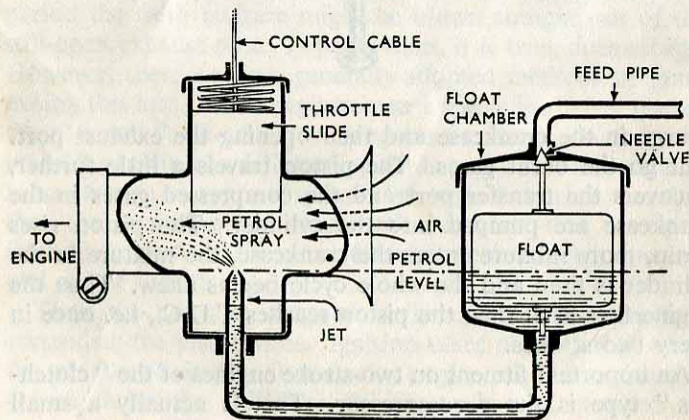

*Diagrammatically explained here, the spray-type carburetter is universally employed.*



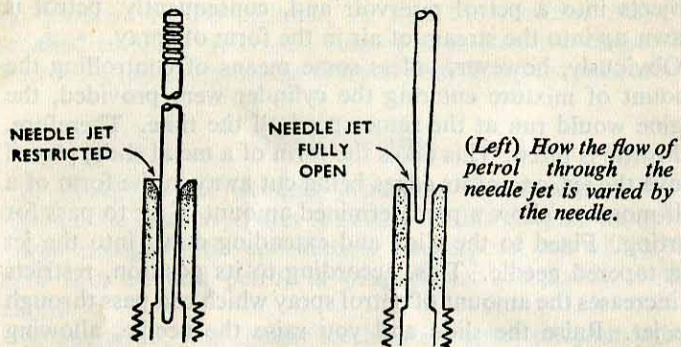

(Left) How the flow of petrol through the needle jet is varied by the needle.

(Right) The relative range of control exercised by the pilot jet, slide cutaway, needle position and main jet is depicted graphically.

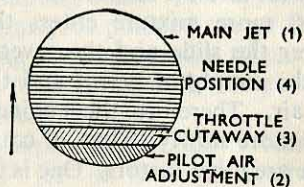

main body of the carburetter by a short neck which is, of course, suitably drilled so that the petrol may pass from one to the other.

### Lubrication

We must now deal with an important aspect—that of lubricating the engine. We have seen that the engine works by burning a quantity of gas. Naturally, this generates a considerable amount of heat and more is produced by friction in the engine itself, caused by the motion of the various parts.

Lubrication has two purposes. Firstly, it must ensure that the friction between the moving surfaces is not unduly pronounced and, secondly, it must help to absorb the heat produced both by the burning of the gas and by internal friction.

Which parts require lubrication? Obviously the piston, which must slide smoothly up and down the cylinder. Also the bearings—usually either of the ball or roller type—on which the crankshaft runs. Then there are the connecting rod bearings. That which is interposed between the lower end of the rod and the crank-pin—a self-explanatory term, that—is termed the “big-end”. This bearing undergoes great strain and its lubrication is important. Then there is the other bearing on the connecting-rod—this is called the “small-end bearing”. Through this passes the “gudgeon pin” which holds the piston to the rod. This small-end bearing—normally it is a plain bush of phosphor-bronze—is subject mainly to heat. If the lubrication is inadequate, the life of these bearings will be unduly short. Also, of course, there is the danger of the piston expanding under the heat and “seizing” in the cylinder, i.e. becoming too big to slide up and down.

In a two-stroke engine, the lubricating oil is usually mixed with the petrol, which—as we have already seen—is admitted, as a spray, to the crankcase. This mixture is called “petroil” and it consists of oil and petrol in the proportions of one part oil to between 16 and 24 parts of petrol—half a pint of oil to each gallon or gallon-and-a-half of petrol, in other words.

Providing that the correct grade of oil is used and the “petroil” is thoroughly mixed beforehand, the system is perfectly satisfactory. Use of oil of too thick a grade may result in the mixture being too heavy to pass through the carburetter jet in sufficient quantity and the engine will therefore over-heat and “seize-up”. Much the same trouble can result from mixing too much oil, even of the recommended grade, into the petrol. The mixture is again too “thick” and so less can pass through the jet. Careless mixing can result in trouble—a fate avoidable by the use of special two-stroke oils such as those produced by the Castrol or “Filtrate” people. These lubricants mix readily, and cannot gravitate to the bottom of the tank.

In the one example of a four-stroke cyclemotor, the oil is

simply poured into the crankcase through an orifice. It is then thrown to the various parts of the engine by the flywheels.

### The Electrical Equipment

In considering the electrical equipment, one must take a certain amount for granted. It must be accepted that lines of force, which are really potential electrical current, are always flowing between the two poles of a permanent magnet and that, when a wire is passed across these lines, a current is induced within it. That is the simplest view of the generation of primary, or low-tension, current.

Further, one must accept that when one wire is coiled about another, but is insulated from it, a current generated and then interrupted in the inner coil will produce an electrical current in the surrounding wire. By regulating the number of

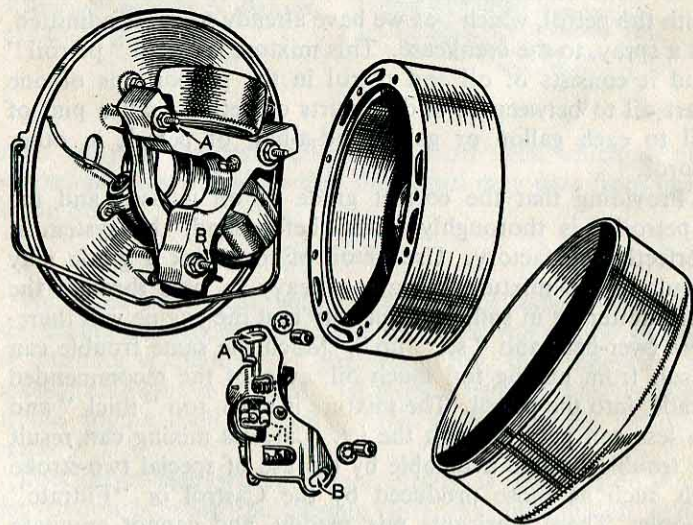

*Flywheel magnetos are widely employed on cyclemotors. Typical is this Wico-Pacy product. The contact-breaker mechanism (shown detached) is located on studs A and B.*

coils contained in a circuit, one can proportionately increase the intensity of the current which is generated.

How does this theory affect the cyclemotorist? Well, his engine is usually fitted with what is known as a flywheel magneto which provides the electrical current for igniting the mixture. On some units, electricity is also supplied for the operation of the lights.

The flywheel magneto consists of a hollow flywheel which is fixed to the engine shaft, rotating with it, and a backplate carried either on the crankcase or on an extension of it. Mounted around the inside of the flywheel are permanent magnets, while the wire coils are carried on the backplate. Each coil consists of a primary winding of a small number of turns of thick wire, surrounded by a secondary winding of many turns of thin wire. Also carried on the backplate is the contact-breaker—a form of mechanical switch—worked by a cam, which opens and closes the contact-breaker points. Included in the layout is a condenser, which prevents too great a build-up of electricity.

Screwed into the cylinder head is a sparking plug. Basically, this is a central electrode—insulated from a steel body which also carries an electrode—connected to the secondary windings by a high tension lead. The plug body, of course, is “earthed” to the machine itself.

When the flywheel is rotated, it generates current in the primary windings of the coils. The cam then opens the contact-breaker points, thus interrupting the current. The immediate effect is to generate a high-tension current in the secondary windings. This current races down the lead to the plug and—carried on by its own momentum—jumps the gap between the plug points in the form of a spark. As we learned earlier, this spark is timed to coincide with a certain position of the piston—usually a few degrees before the piston reaches T.D.C.—and thus the mixture in the cylinder is ignited. Certain magnetos also incorporate additional coils to supply current for lights. These are called “flywheel magneto-generators”.

## "THE LAW REQUIRES . . ."

It is impossible to stress too heavily the importance of being fully acquainted with the laws applying to motor vehicles—for that is, in fact, what a bicycle fitted with a cyclemotor becomes.

The first point is that every user of a motor vehicle must, before he drives his machine on the road, be covered by insurance against third-party risks.

What does this mean? Well, you might be unfortunate enough to have an accident involving personal injuries to some other person, or damage to another's property. That person—the third party, in other words—might sue for damages and a successful claim against you, if you happened to be uninsured, could mean hardship for both parties. It was to guard against such situations that the Road Traffic Acts of 1930–34 introduced compulsory third-party insurance. But, of course, the wise man had always taken that precaution.

It should be realised that such insurance does not relate to the machine, but only to the *rider*. In effect, you propose to the insurance company that it will indemnify you against the risk of an accident, involving a claim for damages, occurring when you are driving your machine. In many cases, this insurance will cover you should you wish to drive another machine, but it does not cover a friend or a prospective purchaser who wishes to drive *your* machine, and it is an offence to loan the model to any driver who is not properly insured. The types of rider who use the machine in respect of which the insurance has been issued are set out on the policy and it is better to refrain from riding your own machine, or any other, until you have received either a certificate of insurance or a cover note and have studied its provisions.

Third-party insurance, then, protects you against claims by others. It does not, however, cover damage to your machine or loss by theft or fire.

Policies covering such eventualities may, nevertheless, be obtained. These are termed "Comprehensive" policies and a good investment they are, too—especially in the case of a motor-assisted bicycle, where the terms are extremely reasonable. Even here, though, one may find oneself on thorny ground unless the implications are thoroughly understood. Few companies, for instance, undertake to make good the loss of tools or accessories unless the machine itself is stolen at the same time.

Be sure to keep an eye on the expiry date of your policy. Generally, the company will send you a reminder and may even issue a temporary cover note to bridge the gap should you fail to renew the policy by the correct date. Even a minor accident may, however, involve you in a law-suit or a prosecution and it would be pathetic indeed if all that resulted from waywardness in completing and posting your renewal form.

A post-war attempt to avoid hardship caused in this way is the Motor Insurers' Bureau—a central fund subscribed to by the tariff and independent insurance companies, and by Lloyds—which undertakes to settle claims against uninsured drivers. Amongst the provisions required by the Bureau are notification of an accident within 21 days, proof of impact and all possible information on the circumstances, the names and addresses of witnesses and so forth. The address of this organization is the M.I.B., 6 Watling Street, London, E.C.4.

Now, how to obtain insurance. In nine cases out of ten, the agent from whom you purchased your engine will be able to issue the insurance for you and to give all the advice you need. Otherwise, pay a visit to the local office or the agents of any well-established company and tell them that you wish to take out a motor insurance. Premiums and terms will be quoted and, if you wish, a temporary cover note—usually valid for 14 days—will be issued on the spot for a modest fee, which is subsequently deducted from your premium.

The law's requirements, however, are not yet satisfied. Next, you must obtain a driving licence—if you do not already possess one. Watch out for a snag here—even if you are the holder of a licence entitling you to drive a car, you may not

be covered for riding a motor-assisted bicycle, which is classified under Group G. If such is the case, you will have to apply for a provisional licence for that group in the usual way.

If you have not previously held a licence, you should apply to your nearest main Post Office, or to your local motor taxation authority, for Form D.L.1. Then, on payment of 5s. you will be issued with a provisional licence, which is valid for three months. When you have attained proficiency in your driving, you may apply on Form D.L. 26 to the nearest Clerk to the Traffic Commissioners (your local Post Office will give you the address) to undergo a driving test, the fee for which is 10s. Some useful tips for a driver taking the test can be obtained from *The Driving Test Fully Explained*.\*

Until you have passed the test, you *must* display "L" plates at the front and rear of your machine. Should you not feel, at the end of three months, that you are ready to take the test, you can renew your provisional licence for a further five shillings and repeat the process *ad infinitum*. But, you will still have to display your "L" plates.

Right! Insurance has been obtained and your driving licence issued. All that now remains is to tax your machine and you will be ready to make your first excursion on the road. Here, again, the agent from whom you bought the engine will probably have attended to this for you. If not, any money order post-office can supply you with form R.F.1/2, which should be filled in and forwarded, with the appropriate fee, to the licensing authority in whose area you reside. You will then be issued with a log book and a licence disc. The disc must be displayed on the near-side of your machine, forward of the driving seat, in a proper holder fitted with a *glass* face—a celluloid type is illegal.

At the same time, the authority specifies the registration number which your machine will bear. This number must be carried, in letters of regulation dimensions, on plates fitted to the front and rear of your machine.

A point which, if overlooked, might lead to trouble is your

\* 4th edition, 5s. net, Temple Press Limited.

bicycle bell. This is illegal on a motor vehicle and it should be replaced by a horn. And don't forget to add a rear red reflector—which your bicycle *ought* to have anyway!

So far, we have considered only the position of the buyer of a new unit. Possibly, you may be contemplating buying one that is second-hand, either from a private seller or from a dealer. All the foregoing remarks still apply. You must be in possession of a driving licence; you must be covered by third-party insurance and the machine must be taxed before you are entitled to use it on the road. That, incidentally, includes pedalling it—without the engine running—while the motor is in place. Unless it is immobilized by the removal of a vital part, it is still a motor vehicle.

If you are buying the unit from a private person you may be told that "There's nearly a full year's insurance to go with it." Be careful! As we have seen, the third-party insurance covers, not the machine, but the *man* against claims. The insurance can be transferred to you with the permission of the company who issued it, but until that permission has been obtained you will *not* be covered by it.

The time will come when you have to renew your taxation. To do so, apply at a main post office for Form R.F. 1a and, having filled it in send it, together with your log book and the necessary fee, to your local licensing authority. It is permissible to use your vehicle for 14 days after the expiry of the taxation but, if you do, you are obliged to renew the taxation for the fresh period.

So much for that side of the legal angle. Those, however, are not the only laws you are bound to observe. In fact, to detail thoroughly all the requirements of the various Acts appertaining to motor vehicles would more than fill this book! The most important points are summarised in *The Highway Code*, which will be issued with your first licence. Study this little booklet—it contains a mine of information and advice. And, having studied it, adhere to it.

## CHAPTER V

## RIDING A MOTOR-ASSISTED BICYCLE

OF ALL power-driven road vehicles, the motor-assisted bicycle is the simplest in conception and the easiest to master. It has only the bare essentials in the way of controls and its weight is little greater than that of an ordinary pedal bicycle.

Normally the handlebar layout will include a throttle, controlling the speed, and decompressor, which releases the pressure in the cylinder, thereby allowing the machine to be pedalled for starting. This lever is also used for stopping the engine. Friction-drive types often incorporate a means of raising the roller out of contact with the tyre, while positive-drive units normally have a clutch—a series of plates held tightly together in a casing by springs—which is interposed in the drive. This is so arranged that operation of a lever pushes the plates out of contact, thereby allowing the engine to run freely without the power being transmitted to the wheels.

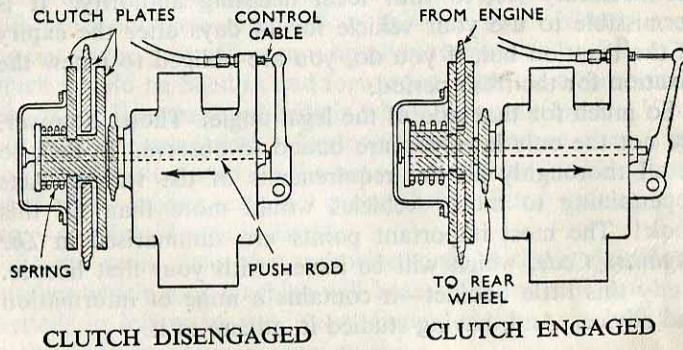

*How a clutch works. On the right, the plates are held tightly together by springs. Movement of the clutch arm operates a rod which relieves the spring pressure (left) allowing the plates to run free.*

The throttle may be one of two types—either a simple lever or a movable handlebar grip. In each case, it is moved towards the rider to accelerate and away from him to stop. Normally it is fitted on the right-hand side of the bars.

Where a separate decompressor lever is used, it will be found on the opposite side to the throttle. However, several designs feature a neat combined throttle and decompressor control. In this, the throttle is operated in the normal way, the engine being fully shut off when the lever is centrally placed. To bring the decompressor into play, the lever is simply pushed forward and thus the two controls can be operated by one hand.

Many different methods are employed for freeing the engine from the wheel. Some units are lifted by a cable, operated from a lever carried on the left handlebar, while others—such as the “Power Pak”—have a lever attached to the engine itself, locking in a “gate”. Positive-drive types, such as the “Cyclemaster” and “V.A.P.” have the friction clutches, already mentioned, controlled from a handlebar lever. These levers often have a small catch which holds the clutch out of engagement, thereby allowing the rider to pedal the machine freely, either with the engine running or with it shut off.

As a general rule the brakes employed are those normally fitted to the bicycle, and these are, of course, operated from the existing levers. Both the “Cyclemaster” and “Winged Wheel”, however, incorporate a separate brake.

Before venturing on to the road with the machine, it is advisable to spend an hour or so becoming familiar with the controls so that, in an emergency, appropriate action can be taken without delay.

Once you have “got the feel” of the machine, you are ready to take your first ride under power. Before doing so, however, take a trip round the block pedalling the machine in the normal manner, especially if the engine has been fitted to a bicycle with which you were previously familiar. This will show you how the fitting of the unit has altered the weight distribution and the handling characteristics.

Right! Now turn on the petrol and allow the float chamber to fill. If the chamber is fitted with a "tickler"—a small button which depresses the float—give it two or three dabs to obtain a richer-than-usual mixture. Close the air strangler on the carburetter—fully if the day is cold, partially if it is warm—engage the drive, set the throttle at the half-open position if a separate lever is fitted, and operate the decompressor.

Now cycle away. The engine will be turning over as you do so. When you have reached about 5 m.p.h., release the decompressor lever and the engine will begin to fire. As soon as it has settled down to a steady buzz, open the strangler fully.

To stop, you merely reverse the process. Shut the throttle and allow the machine to slow down against the compression of the engine. When it has decelerated to 5 or 6 m.p.h., operate the decompressor and apply the brakes. It is advisable to practise starting and stopping a few times on a quiet road before taking the machine through traffic, just to give yourself confidence.

Once you have mastered these two points, increase the scope of your trips. Remember, however, that you have become a motorist and drive accordingly. You will be travelling at a higher sustained speed than that to which you were accustomed as a cyclist and, therefore, more attention must be paid to the road ahead and to the giving of hand signals. To pedestrians, too, you may still appear to be a cyclist and some unwary walker, not realising that you are travelling considerably faster than the average pedaller, may step into your path. So keep an eye open for any such eventuality—it may save you from taking a tumble.

Traffic driving with a cyclemotor-equipped machine demands careful use of the throttle and decompressor. On busy roads try to keep as close as you can to the near-side kerb, thus avoiding any risk of being caught in the middle of a stream of traffic. Generally speaking it is advisable to keep close in to the side at all times, except in those cases where you wish to turn off to the right. Then, when the road is momentarily

clear, move over onto its crown and give a clear signal well before you start to turn. If your unit has a clutch, you can keep the engine running when halting for traffic lights, "zebras" and similar impediments. Then, moving off again, you can pedal gently for the first few yards, at the same time letting the clutch lever slowly home.

There is a point here, though, for the owners of friction-drive attachments with a handlebar-controlled "free" position. This is *not* a clutch and it should never be used as such. It is possible to raise the engine from the tyre while it is still running. If you attempt, however, to lower it on to the tyre again when you are standing still the whirling roller will simply rip the tyre tread and a perfectly good cover will soon be made unusable. This control is fitted only for convenience, to allow the machine to be pedalled like a normal bicycle. To use it for any other purpose is to court trouble.

Thus, in cases such as those detailed above, the correct procedure is to stop the engine by using the decompressor and to re-start in the normal way. With practice, one can raise the engine while it is running, stop, pedal away and *then*, at about 8 m.p.h., lower the unit. Even so, habitual use of this method of re-starting will reduce tyre life.

It is, of course, on hills that the cyclemotor really comes into its own. On gradients which, previously, had meant tiring pedalling—or even dismounting—these little engines will pull strongly and steadily. Naturally, they will not carry a heavy rider up a steep slope unaided, but, with reasonably light pedal assistance, it should be possible to surmount even the steepest main road hills with less "push" than you previously had to apply on the flat.

Here, driving technique counts. Rush tactics pay dividends, especially with the lower-capacity units. Approaching the hill, open the throttle fully and gain as much speed as possible before commencement of the climb. Do not leave the pedalling too late—once the engine revolutions have fallen and the unit is struggling, you will have to pedal hard to maintain way. Instead, start to pedal early—you will find it no harder to pedal uphill with a cyclemotor than it was to pedal on a

slight downhill slope with an ordinary bicycle—and thus assist the engine *before* it begins to labour. Not only will this mean easier riding for you, it will ensure that your engine will work under better conditions and will, therefore, last longer.

Sometimes it may be found that a slightly richer mixture will assist the hill-climbing performance. On machines where it is within reach from the saddle you can achieve this by partially closing the strangler—not fully, or the engine will refuse to run, but, say, a quarter closed. Do not forget, though, *to open the strangler again once the climb has been completed.*

On a long downhill run there are several techniques which may be used. The engine can be stopped and, if a handlebar “lifting” control or a clutch is incorporated, freed from the wheels, the machine being allowed to coast down the hill. This is only recommended though, where a really efficient pair of brakes is fitted.

Another way of giving the engine a rest is to operate the decompressor at intervals, keeping it open for 20 seconds or so, then giving a short burst of power, followed by a further period on the decompressor. It is inadvisable to keep the decompressor in use for longer, however, for otherwise there is the danger of wetting the sparking plug and being unable to re-start the engine. Alternatively, the hill can be descended on a very small throttle opening.

What one should never do is to descend a long hill with the throttle fully closed. *Always* give the engine short bursts under power when coasting. The reason is not far to seek. You will remember that the lubricating oil is mixed with the petrol and is admitted with it to the engine. But closing the throttle cuts off this supply and thus the unit receives no oil. On a long descent this would entail the danger of the engine “seizing”—i.e. of the piston, which expands under the heat generated by friction between itself and the cylinder, “locking up” in the bore. Should this happen, a skid might result and, in any case, a seizure does no good at all to the engine.

## MAINTAINING YOUR MACHINE

THIS IMPORTANT chapter must commence with a word of warning—several words, in fact. First and foremost, before you even consider fitting an engine to your pedal bicycle, read the section dealing with the maintenance of the bicycle itself and check your machine thoroughly. If it is not in first-class order, have the defects made good. To add a cyclemotor to a machine which is in bad fettle is to run the risk of a crash, with possible injury to yourself and to innocent passers-by.

The advice given here is sufficient to enable you to carry out day-to-day tasks on both the bicycle and engine parts, but it does not extend to the “complete overhaul” stage, for the very good reason that only a minority of cyclemotorists would wish to strip their machines down to the last nut and bolt. Of course, a motor-assisted bicycle is relatively uncomplicated, but unless you are a qualified mechanic, amateur or otherwise, you will be well advised to go no further than top overhauls—that is, work in which the crankcase and crankshaft of your engine remain undisturbed.

Now, what are the points most likely to need attention on a bicycle to which an engine has been fitted?

### The Bicycle Parts

First and foremost is your stopping power. Before attempting to motor it is essential to see that your brakes are in first-class condition. If you have internal-expanding brakes—more commonly known as “hub brakes”—then your job is comparatively simple. Normal adjustment, as advised by the manufacturer, is the order of the day. Should a hub brake “squeal” when applied, the lining is glazed and the action of the brake will be sudden and severe. If the lining is at all near the stage where replacement is deemed necessary,

then reline at once. The amount of wear on brakes on a bicycle that is motor-assisted is far greater than that experienced on an ordinary "one manpower" bicycle.

Rim brakes are a very different matter, for here the mechanism is exposed and simple in operation. The caliper brake, operated by a cable, is usually of the side-pull type and, so long as the metal of the actuating parts is not fatigued and the cable is not frayed, then there is little to bother the rider. In operation, the caliper brakes close, like an engineer's calipers, and brake blocks, which are held in the brake shoes—come into contact with the wheel rim. It is essential to see that all the moving parts are easy in action and well lubricated. The brake blocks should be adjusted and "squared up" to the rim, so that the greatest possible friction area is used. In some instances, centre-pull caliper brakes may be fitted. The maintenance of these is virtually the same as for side pull, and neither is difficult to understand or to maintain.

On older machines of the Roadster type, roller lever, rod-controlled brakes may be fitted. These brakes are the "pull-up" type, operated by rods, and are simple in construction and operation. This simplicity is naturally reflected in their maintenance, which is confined to loosening one nut and either slacking off or taking up the play in the rod mechanism.

Now comes the question of brake blocks. These are made in various sizes for different makes of brakes and number nearly 50 different patterns and sizes. Make sure that the blocks fitted in your brakes are in sound condition. If they are not, renew them at once—and make sure that the replacement blocks fit!

In the case of some of the higher-powered units, the existing cycle brakes may be incapable of providing sufficient braking power, especially under wet conditions. In such cases as these, it is advisable to spend a couple of pounds to have built in to the rear wheel a coaster hub brake—a "back-peddalling brake" as it is usually called—such as that produced by the Perry Chain Co., Ltd. Impervious to weather conditions, such a brake is an investment in safety and well worth the slight additional cost.

Following closely on brakes come tyres. If the motor attachment you have fitted drives on the tyre, then start off on the right foot and have a specially constructed cyclemotor tyre fitted. Whatever tyres you have on your bicycle, though, must be inflated hard for two very good reasons. Firstly, a bicycle tyre is so small in size that under-inflation will cause early wall failure and, secondly, with a friction drive on the tyre, it will result in "drive slip" which, in time, will cost you a new cover.

Wheels are an important factor on the motor-assisted bicycle for, in many instances, the machine will be travelling at a faster gait than ever before—and for much longer periods. The spoke gauge on most machines is ample for the job in hand but should the reader who has an attachment on a very light machine find that spoke breakages are becoming the rule rather than the exception a complete wheel respoking, using 12-14 gauge double-butted tandem spokes, is indicated. Normally, though, this will not be necessary except, perhaps, in the case of a very heavy rider or an exceptionally old wheel. One point, however, is essential—the wheel must be kept in perfect alignment for, at speeds of 20 m.p.h. or so, the effect of a powered drive on a buckled wheel can be very hard on the tyre, to say nothing of the danger of its effect on handling.

A "wobbly" wheel which, at first, appears to be buckled may well be traced to badly adjusted hubs and it is with those components that we shall deal next.

Bicycle hubs disclose a greater diversity in detail between various types than almost any other part of the machine. The basic design is the same for nearly all of them, however. They are made up of a hub shell, spindle, cones, adjusting nuts, washers, locknuts, ball cups, etc. All bicycle hubs are of the "cup and cone" type and adjustment, even to the finest limits, is an essentially simple operation.

The basis of the hub is, of course, the shell into which goes the spindle, at each end of which is a cone. One end of the spindle is the "locking end"—in other words the cone there is locked into place. Once this has been located on the spindle and locked, the unit as a whole is inserted into the



Hub adjustment is important. Right are depicted the normal facilities for adjusting the bearings and (below) a hub in correct adjustment sectioned.

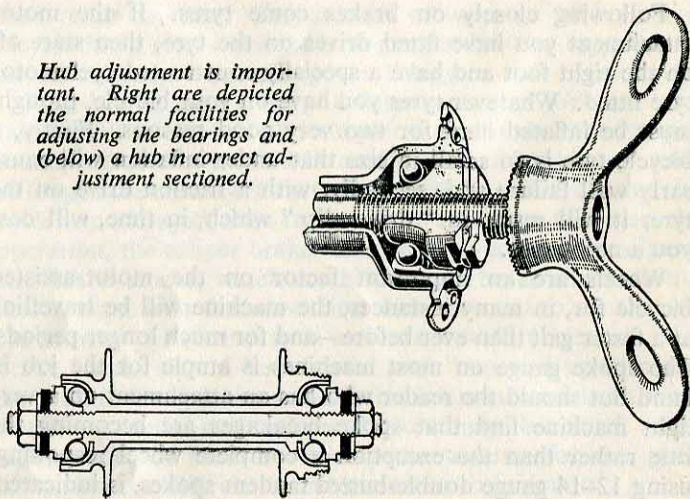

shell and the second—the “free”—cone is screwed home. Next, the washer goes on and finally the lock-nut. Adjustment for the hub is carried out on this one “free” cone. Correct adjustment is obtained when the cone has no side-play or up-and-down movement and yet it is possible to spin the wheel around the hub with no trace of binding.

We have gone to some length in explaining adjustments of this component, for it is essential that there should be no play whatsoever in the hub. Play in the rear hub, especially, may cause uneven tyre wear, severe and frequent spoke breakages and lack of stability.

Badly adjusted front bearings will certainly cause bad steering that may, at speed, be felt through the steering head and handlebars. Worn bearings can have a worse effect on the steering than a badly buckled wheel.

Having mentioned the steering head let's take that next. There are two main types, or patterns, in common use nowadays and they differ only in the method of securing the fork to the handlebar. They are known as “expander fixing”

and “clip fixing”. The expander type is the more common of the two, although on old machines the clip type is in the majority. The sudden change does not mean that the clip type is less effective—it is merely a matter of vogue among cyclists.

Adjustment is a simple matter. At the top of the head assembly, just underneath the handlebar stem, will be seen a large locknut. Loosen this and the main cone for the top race—upon which all adjustment is made—will be easily turned. The best way to test for slack head bearings is to put the front brake on hard and push the bicycle forward against the locked wheel. If there is any movement at the head, then the bearings are slack and the top cone should be turned until the play has been taken up. Make this adjustment without locking it home. When this is completed loosen the cone half a turn and then tighten the locking nut home. The additional pressure of the locking nut will take up the half-turn you gave the cone and a perfect adjustment should

- 8. Fork Stem
- 11. Handlebar Stem
- 12. Head-race
- 15. Lamp Bracket
- 16. Locking Ring
- 20. Head-clip
- 21. Clip Bolt

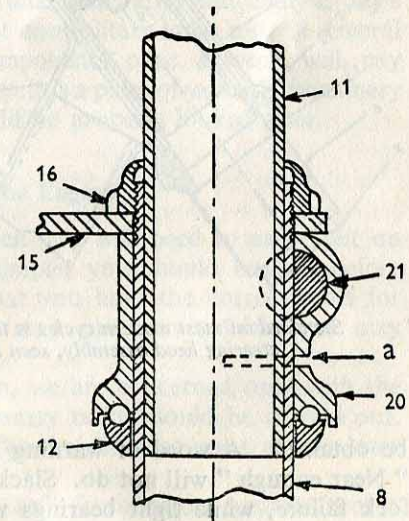

Older cycles may employ the clip-type of steering head shown here.

1. Head Tube
2. Top-tube Lug
3. Top Tube
4. Down-Tube Lug
5. Down Tube
6. Fork Crown
7. Fork Blade
8. Fork Stem
9. Handlebar
10. Handlebar Lug
11. Handlebar Stem
12. Head-race
13. Fork-race
14. Adjustable-race
15. Lamp Bracket
16. Locking Ring
17. Expander Bolt
18. Washer
19. Expander Cone

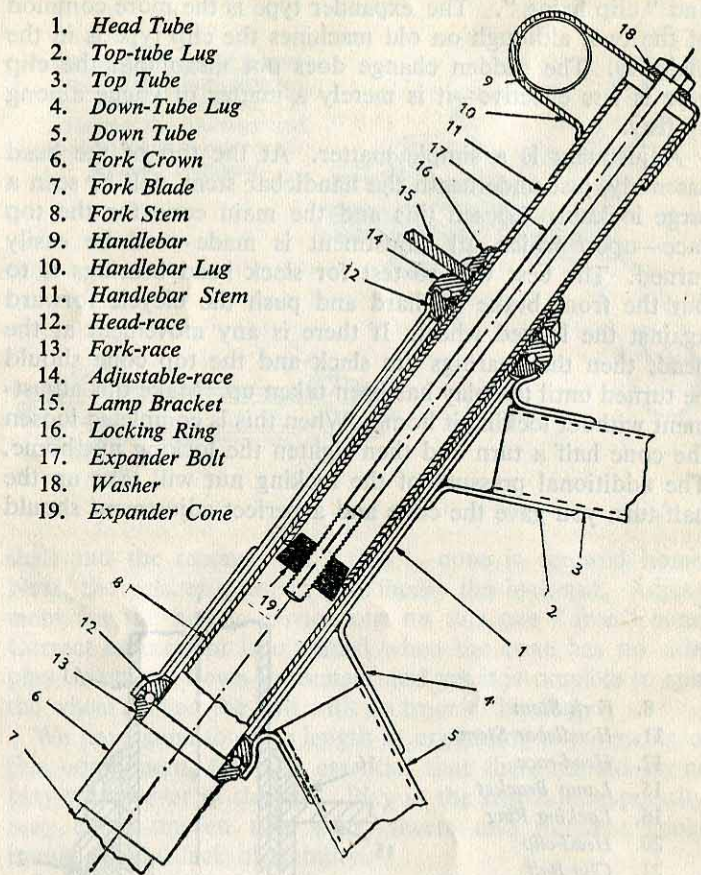

Standard on most modern cycles is the expander-type of steering head assembly, seen here in section.

be obtained. A word of warning about head adjustment—"Near enough" will not do. Slack bearings will cause early fork failure, while tight bearings will make steering almost

an impossibility. Better a little trial and error before getting the right adjustment than trial and error on the open road.

Naturally, when you have power assistance, it is not essential to have the saddle set high. Admittedly, the higher the saddle the better the leverage and pushing power, but lowering the saddle until the foot can be placed on the ground with the rider still seated is advantageous when stopping at road junctions and traffic lights. The loss of pedalling power is so slight that it can be disregarded. Controllability when on the move will also be greatly enhanced by the lower weight distribution on the machine, for it should be borne in mind that the total weight of the machine is in the region of 50 lb., while the weight of the rider is in the region of 150-200 lb.

When a bicycle is fitted with a cyclemotor it usually means that it will travel farther and faster than the normal cyclist could pedal it. For this reason, it is essential that mudguards, saddle, chains, handlebars and brakes be in perfect adjustment so that they do not shake loose when travelling. Nothing is more irritating than an unknown rattle and many a day's travel can be ruined by just one solitary loose nut. A general "overhaul" of these components once a week will pay handsome dividends. A bicycle is a piece of valuable machinery and, for that reason, should be properly looked after.

### The Engine

Although the work which you will need to carry out on your cyclemotor is but simple, you should ensure, before commencing any tasks, that you have the correct tools for the job. Otherwise, you may run into trouble and may possibly damage the unit.

In this particular section, we are concerned only with the manner in which the necessary tasks should be carried out. The detailed instructions for the different units appear later in the book.

As far as a two-stroke unit is concerned, apart from a

periodical check to make sure that all nuts, bolts, screws, etc. are tight and the cables properly adjusted, there are only three points which will demand regular attention.

Firstly, the interior of the combustion space must be kept free from carbon deposit. This is a form of hard soot, caused by the burning of the mixture. An engine in which this "soot" has been allowed to accumulate is in much the same position as an unswept flue—it cannot burn its fuel properly or rid itself of the products of that combustion.

Decarbonising is a simple job, provided it is tackled methodically. As we shall be baring the internals, the first step is to clean the outside of the unit with paraffin and a stiff brush, removing all the dirt and thereby ensuring that none can find its way into the mechanism. Then, dismantling can start.

Undo the nuts holding the exhaust pipe and silencer and detach it. Then remove the carburetter—or, if you wish, the body may remain *in situ* and the slide can be removed. This, of course, is reached by unscrewing the knurled ring on top of the carburetter body and drawing out the slide and needle by pulling the cable clear.

Place all the detached parts on a table or shelf covered with clean newspaper. Then unclip the H.T. lead at the sparking plug terminal and remove the plug. Disconnect the cable controlling the decompressor—if one is fitted—and coil the cable neatly, fixing it to the cycle frame to keep it out of harm's way.

So far, so good. Next, loosen off the cylinder head nuts until each is finger-tight. This should be done progressively, each nut being undone a few threads at a time. Remove the nuts and place them on the shelf in order, so that when the engine is re-assembled they are properly replaced on their original studs.

Now slide the cylinder head off its studs. It will probably come away quite easily but, if it sticks, resist the temptation to insert a screw-driver between the barrel and head and lever it off. The most likely result would be a broken fin or a badly damaged head joint. Instead, tap the head gently on each side with a block of soft wood. This will "unstick" the

head joint without the slightest risk of any damage resulting.

With the head removed, turn the flywheel until the piston is at the top of its stroke. The carbon may now be scraped off the crown, either with a blunt kitchen knife, a proper scraper or a wedge-shaped piece of hardwood. When the deposit has been removed, polish the piston crown with a piece of well-worn fine emery cloth.

Repeat the process with the cylinder head, first removing the decompressor valve. Take especial care to free the recessed portion of the sparking plug hole and the decompressor valve surrounds from carbon, for any small particles left in these areas may become red-hot and ignite the mixture prematurely.

With the piston at the bottom of its stroke, scrape out the exhaust port, finishing it off with emery cloth. Probably there will also be a ring of carbon just at the top of the cylinder bore. This should be carefully scraped, but emery cloth should never be used at this point. Wash out the cylinder with petrol to remove any carbon chippings which have fallen into it.

The exhaust system is the next consideration. Probably the best method of clearing this is to burn away the carbon with a small gas burner. Suitable burners, which may be plugged in to a gas jet, are obtainable from hardware stores for three or four shillings. However, your house may be "all-electric", in which case you should mix 2 lb. of caustic soda into a gallon of warm water and leave the exhaust parts immersed for 12 hours or so. The soda solution will eat into the carbon and the softened remnants may then be scraped away. This system cannot be used, though, where the exhaust components are made of light alloy, for the caustic will corrode the metal. In such cases, the carbon must be scraped away.

It but remains to clean and polish the decompressor valve and then to grind it in to ensure a gas-tight joint. Smear a little fine grinding paste—a tin of paste is obtainable from your local dealer—around the valve face and push the valve back into place. Insert a screwdriver into the slot in the head and twist the valve back and forth through half a turn, exerting a gentle pressure on the screwdriver. Repeat about a dozen

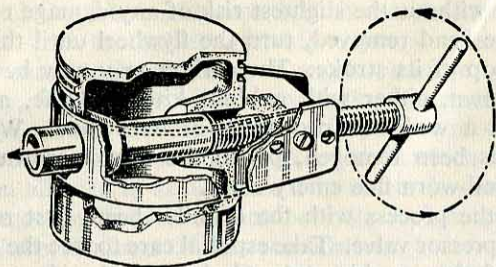

*On larger units, a gudgeon pin extractor may save the piston or connecting rod from damage during dismantling.*

times and then lift the valve and turn it through 90°, continuing to grind in as before. Carry on repeating this procedure until the valve seatings, on the valve and in the head, are smooth and matt grey in colour. Then wash both valve and head with petrol to remove any paste that is left, and re-assemble the decompressor.

Replace the head and the exhaust system, using new gaskets, and seal the joints with compound if the manufacturers so recommend. The head nuts should be tightened a few threads at a time, so that the head is progressively and evenly brought into contact with the cylinder.

On alternate "decokes", the barrel should be removed and the piston detached. It will usually be found that the gudgeon pin, on which the piston is held, is located by a wire circlip on each side. These little wire "hoops" can be removed by springing the ends towards each other and carefully withdrawing them with a pair of long-nosed pliers. Take care not to let them drop into the crankcase, though!

Carefully remove the piston rings by springing them out of their grooves. Scrape the carbon off the top and the inner surfaces of the rings and then, with a piece of broken piston ring, scrape the carbon from the ring grooves in the piston. Next, examine the interior surface of the piston crown. You will probably find that carbon has formed on it and this

should be scraped away and the surface finished off with emery cloth. Needless to say, though, emery cloth should never be used on the working side surfaces of the piston or rings.

Re-assembly is a fairly simple job, but you must be careful when replacing the rings to engage their ends with the small pegs which are fitted in the grooves of most two-stroke pistons. These pegs prevent the rings from turning. Once both rings are properly seated against their pegs, slide the cylinder barrel into place, compressing the top ring with your fingers so that the barrel can slip smoothly over it. Then repeat with the lower rings. Once the barrel is in position, proceed as before, replacing the head, exhaust system and, of course, the carburetter.

So much for decarbonising. The second task is a very simple one—merely to attend to the modest needs of the fly-wheel magneto. This asks only two things—that the contact breaker points should be kept clean and properly gapped and that the cam-pad should, from time to time, be given a few drops of thin oil.

To check the gap, on most units, remove the magneto cover

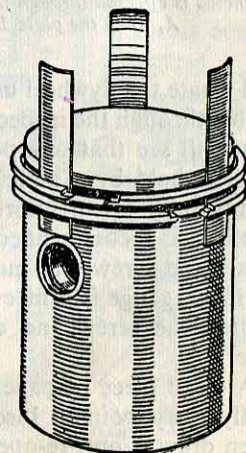

*A simple method to avoid breaking piston rings when removing or replacing them is to employ thin metal shims as shown.*

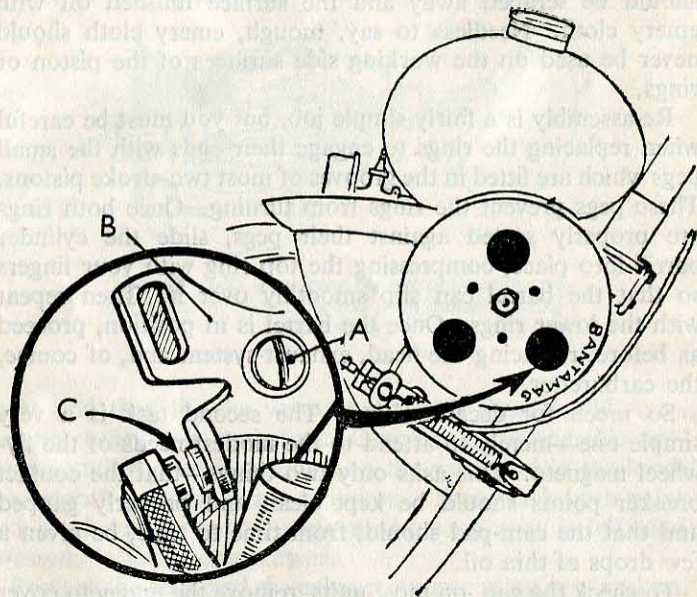

Adjustment of the contact-breaker points on units employing Wico-Pacy magnetos is effected through the marked inspection hole. Loosen the screw A, when the plate B can be moved to alter the gap C.

and rotate the flywheel until the contact-breaker mechanism is visible through the inspection hole marked "Set points here". You will see that one point is carried on an arm, while the other is held by a plate secured by a large screw. With the points fully open, insert a feeler gauge and check that the gap is that recommended by the makers. If it is not correct, loosen the screw and move the plate backwards or forwards until the gauge is a nice sliding fit between the points. Then tighten the screw and check the gap once more to make sure.

A clean piece of paper is all that is required to clean normally dirty points. Insert it and close the points upon it. Then draw it out, re-open the points and re-insert the paper.

Repeat the drill until the paper shows no sign of dirt upon withdrawal from the points. If oil or petrol have found their way onto the points, however, burning will have taken place. In such a case, they should be lightly polished, either with piece of smooth emery cloth or with a specially fine file, obtainable for the purpose from your dealer.

From time to time, examine the H.T. lead and make sure that no cracks have developed. Should either the lead or its insulator be damaged, replacement is the best policy, for repairs—especially to a component so cheap to replace—are rarely satisfactory, by reason of the high voltage which the cable has to carry.

Then, there is the carburetter. Little can go wrong with this except a stoppage caused by grit, dirt or fluff. Here prevention is both better and easier than cure. Periodically you should remove the float chamber and the needle jet and

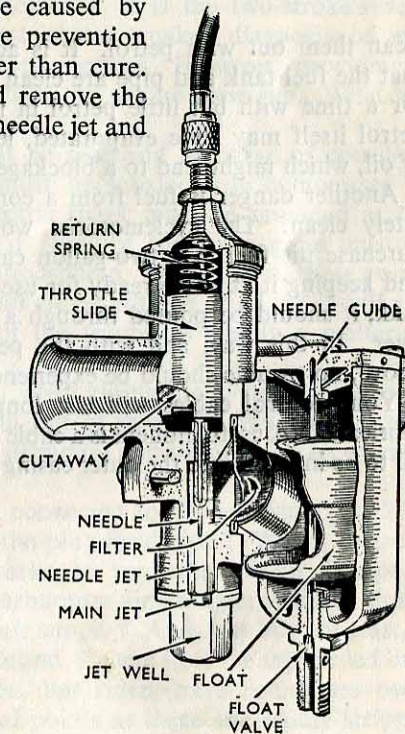

The special Amal carburetter employed on many British cycle-motors.

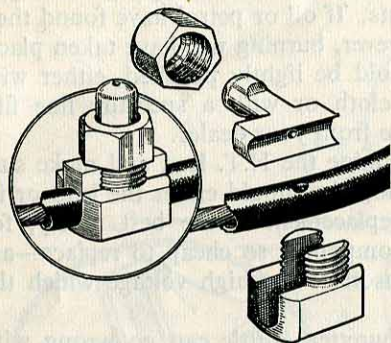

*Lubrication of control cable is facilitated by the use of a Kirk cable lubricator shown here.*

clean them out with petrol. It is advisable, also, to ensure that the fuel tank and pipe are clean as, if the unit has stood for a time with but little petrol in it, it is possible that the petrol itself may have evaporated, leaving a surface coating of oil, which might lead to a blockage.

Another danger is fuel from a container that is not absolutely clean. The cyclemotorist would be well advised to purchase his fuel in a two-gallon can, mixing it "in bulk" and keeping it at home ready for use. When placing it in the tank, it should be poured through a funnel with a fine mesh filter. In this way, and with the periodic cleaning outlined above, no trouble should be experienced with the fuel system.

Your control cables will last longer if they are properly lubricated. A useful fitment is a cable lubricator, which enables oil to be injected into the outer casing.

## IF IT STOPS . . .

WHILE THE modern cyclemotor is both a reliable and a long-suffering product, a day may come when your particular example may obstinately refuse to run. Don't be alarmed—in most cases it will only be a minor fault which you can easily fix yourself.

As the majority of "clip-ons" are two-strokes, it is with that type of engine and its possible defects that this chapter will mainly deal. Paradoxically, it is the two-stroke's very simplicity which, at first glance, makes diagnosis of any complaint it may develop puzzling. However, providing a few conditions are satisfied, the engine *must* run. What are these essentials?

First, the engine must be receiving a charge of petrol/air mixture. This charge must be satisfactorily compressed in the cylinder and an electric spark must be provided at the right moment to ignite it. Finally, the burnt gases must be able to escape into the atmosphere. If any one of these points is at fault, the engine will either not run at all, or it will run erratically. Diagnosis of the trouble is simply a matter of elimination.

Right! Assume that, when riding along on a level road, you have suddenly "run out of power". What is the next step? Obviously it is to dismount and to carry out an external check.

Is the H.T. lead still connected to the sparking plug? Is oil or dirt "shorting" the plug insulation? Water, too, can effectively stop your sparks, so pay attention to that point on a wet day. Has the carburetter air strangler vibrated closed and thereby cut off the air supply? And, last but not least, is there still fuel in the tank and, if there is, is the tap turned on? Elementary stuff, maybe, but riders have sometimes overlooked such fundamental points as these and vainly stripped

their engines by the roadside in search of some hidden fault which just didn't exist !

If the answers to all those questions do not solve your problem, the defect must be within the mechanism. So start to check over each point in turn. First, depress the carburetter float and see if fuel floods out of the chamber. If it doesn't after the float has been held down for about five seconds, it indicates a blockage in the fuel line. Turn off the petrol at the tap, detach the line and blow through it. Check the tap too, for the blockage may be there. If it is blocked, a piece of wire poked through it should clear it. Also examine the union on the float chamber to see if any foreign matter has choked the inlet. A further point—if the tiny vent hole in the tank filler cap is blocked, no petrol can flow out. A useful tip is to check this point whenever the fuel tank is re-filled.

On the other hand, petrol may be leaking out of the chamber, in which case the float may be damaged or the needle either badly worn or held off its seat.

If the fuel system has passed muster, remove the sparking plug and examine the gap. You may find that a tiny "whisker" has formed across it, thereby effectively preventing it from sparking. This "whisker" is really a piece of hard carbon and it is especially liable to form if the unit has been driven hard in a hilly district. The gap between the plug electrodes should be in the region of .018 in., and any appreciable variation in this will probably stop the engine. Check it with a feeler gauge—a visiting card is just about right if you haven't a gauge—and, if it is wider or narrower, reset it by gently tapping the side electrode (or electrodes) towards or away from, the centre.

The condition of the plug, too, can give useful information. It may be covered with soft, black soot, indicating too much oil, or too rich a mixture. If so, clean it with a wire brush and check the gap. Or, it may have a dull grey surface deposit. This indicates hot running and, probably, a weak mixture caused by an incorrect carburetter setting or a partial fuel blockage somewhere.

Again, clean the plug and check the gap. Then, prop the machine up on any convenient support and, laying the plug on the cylinder, spin the rear wheel with the engine engaged. Or you can remove the magneto cover and rotate the flywheel, having first disconnected the drive. A spark should jump across the plug points. If no spark occurs—or if it is weak—the trouble is in the "electrics". First, try a spare plug—you should always carry a new plug of the correct grade with you. If there is still no spark, examine the H.T. lead for cracks or cuts in the outer insulation which may be causing the current to flow into the frame of the machine. In other words, short-circuiting. If the lead is in good condition externally, detach it from the machine and see if the inner wire is broken. This can be done quite simply—just pull steadily on both ends of the lead. If it stretches like a piece of elastic, there is a break somewhere—you will be able to find it by keeping the tension on and pinching at intervals down the lead. A "get-you-home" repair can usually be effected by cutting away the outer casing round the break, twisting the wire together again and sealing the lead with a liberal winding of insulating tape around the joint.

If the lead should not prove to be the culprit, we must go a stage further. You will find that there is, in the terminal plug or on the lead at the magneto, either a carbon rod, spring-loaded on to a contact in the generator, or a small brass contact to "pick up" the current. The rod is called a brush and it may be broken or the contact dirty; clean it, make sure that it is pressing home in the plug and into the magneto and that both contact points are clean. Having done so, again revolve the flywheel and check your spark. If there is still no result, examine the contact-breaker points. See that these are just beginning to open when the piston is almost at the top of its travel. This, of course, is only a rough check, but it is effective. When the points are fully opened, see that the gap between them is no more than .012 in. If it is, adjust them to the correct gap and—again—make sure they are clean. If there is still no joy in the spark department, all the indications are that it is probably a job for your local agent

to tackle and the best course will be to disconnect the drive and pedal home.

Right! Now, what else could go wrong? Just now, we mentioned "weak mixture"—remember, that grey-coloured deposit on the plug? That *could* be caused by a blocked jet in the carburetter. Here, the scheme is to dismantle the carburetter and clean the jet with petrol. You can often clear a jet by blowing through it with a tyre pump—first giving the pump itself a couple of blasts to ensure that it is clean. When replacing the carburetter, make sure that it is vertical, or you may run into more trouble.

There are, of course, other factors which could cause a weak mixture. Extra air would be sucked in if the carburetter happened to be loose on its stub. A bad crankcase joint would weaken the mixture *and* spoil the crankcase compression. If the jets are clear, the carburetter stub joints tight, the spark O.K. and a supply of fuel reaching the float chamber, we are forced back to our last alternative—leakages and loss of compression. If either crankcase or cylinder compression is at fault, the engine will either not work or it will lack power.

With the plug removed, and the machine on its stand or conveniently propped, pull the rear wheel round. You should hear a steady "plop, plop, plop" from the engine. This indicates that the crankcase compression is as it should be. Place your thumb over the plug hole and repeat the operation. You should feel the cylinder pressure trying to lift your thumb and then, as the piston starts to go down again, there should be a pronounced "sucking" effect.

Loss of cylinder compression may be due to loosening of the nuts holding the head, barrel and crankcase in contact; to "blowing" of the joints between them; to piston rings either breaking or becoming "gummed" by carbon into their grooves so that they no longer spring out against the cylinder walls. Or, it might be a damaged piston.

If you possess a fair amount of mechanical ability and have the necessary tools with you, you could remove the cylinder and check these points. If not, leave well alone and seek a knowledgeable garage under your own power.

Loss of crankcase compression usually means that a joint has worked loose. Examine the case for signs of oil which indicate a leak. Should one come to light, check that the bolts holding the crankcase halves together are tight. If the leak still persists, a piece of chewing gum will often effect a temporary repair—one which is, incidentally, also applicable to leaking petrol tanks and the like.

So much for the action to take with a two-stroke that has stopped. Naturally, it is impossible to do more than give a brief insight into what may be wrong and what is the appropriate cure. The defects mentioned in this chapter, however, are fundamental and often play a part in roadside troubles.

A quick look, now, at the causes of erratic running. A progressive loss of power coupled with an engine that sounds unusually subdued indicates that the exhaust system is becoming choked with carbon and that the burnt gases are consequently having difficulty in getting away. Decarbonising is the answer—an operation that was described in the chapter on maintenance.

Loss of power after hard driving in hilly country, especially when it is accompanied by a flat-sounding spit-back from the carburetter, is a clear warning of plug trouble—probably "whiskering". Cleaning the plug, or fitting the spare, is the cure. However, a word of warning. *Never* use a plug of the wrong grade—it is simply asking for trouble. And, should the engine suddenly begin to behave erratically, it is fairly certain that all is not well in this department.

Closely allied to this is "pre-ignition". This is usually caused by an area of carbon in the head becoming red-hot and igniting the mixture prematurely, as we saw in Chapter VI.

Lighting failures are, perhaps, the most puzzling to diagnose—the average mind seems to boggle at the multiplicity of wires, contacts, etc., from which even a simple electrical system appears to be composed.

A common complaint is that bulbs in the lighting system may suddenly burn out—especially if a cycle-type dynamo set



is fitted. The reason is not far to seek. The bulbs fitted to the lamps in such sets are designed to cope with a certain output—that produced when a cycle is being pedalled. The use of a cyclemotor, however, usually results in a greater speed being used for longer periods. What happens? Naturally, the dynamo's output is stepped up and the bulb filaments are called upon to carry a greater load than their designers ever intended. The inevitable result is that they burn out—just as a household fuse will burn out.

The solution is simple. More current is produced, therefore more must be absorbed. This can be done quite easily by fitting bulbs of higher wattage, to bring the total combined wattage of the set up by, say, half a watt. For example, if your cycle lamps were fitted with a head bulb rated at 6 volts 3 watts and a tail bulb of 6 volts .04 amp. (.24 watts)—the most popular combination—a cure could be effected by using replacements rated at 6 volts 3.3 watts and 6 volts .1 amps (.6 watts) respectively. The original combined wattage was 3.0 plus .24 = 3.24 watts; with the new bulbs the figure rises to 3.3 plus .60 = 3.9 watts, an increase of .66 watts. This should effectively cure any troubles in that direction.

It is not improbable that this difficulty may be resolved once and for all by the introduction of attachment dynamo sets specially designed for use with cyclemotors or by the increasing use by cyclemotor manufacturers of flywheel magneto-generators which provide direct current for lighting. In the latter case, of course, bulbs in any existing lamp on the cycle would require to be changed for those of a rating in keeping with the output of the generator.

So much for two-stroke engines. In the case of a four-stroke unit, the procedure is much the same. However, crank-case compression does not enter into it. Additional points to check are that neither valve is sticking open, and that the tappets have sufficient clearance.

In closing, let us repeat our previous warning. Don't attempt to dismantle your engine by the roadside unless you are qualified to do so and have the right tools for the job with you. If you do, you may be unable to re-assemble it

and your final state will be worse than your first. For the average cyclemotorist who is, understandably, not particularly mechanically minded, it is better to pedal home with a "dead" engine if the elementary checks described here fail to bring results.

## PART TWO

### FRICITION-DRIVE CYCLEMOTORS

### POSITIVE-DRIVE CYCLEMOTORS

### MO-PEDS

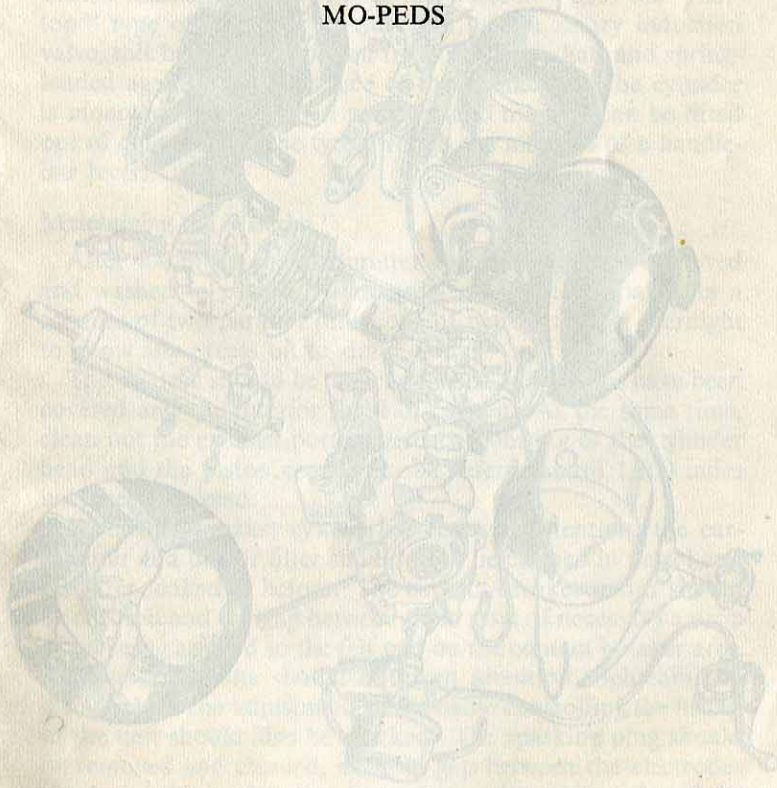

The 32 c.c. "Berini".  
Inset is a view of the  
engine in position on a  
bicycle.

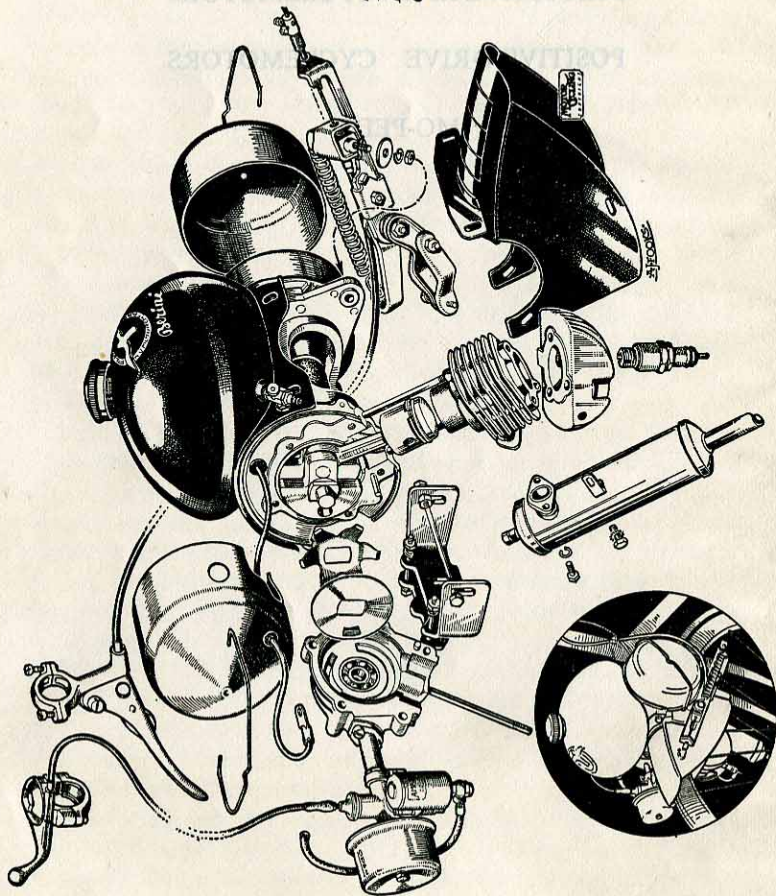

CHAPTER VIII

FRICION-DRIVE CYCLEMOTORS

The 32 c.c. "Berini"

DESIGNED TO drive the front wheel by means of a carborundum-faced roller, the 32 c.c. "Berini" is not now available on the British market. A two-stroke, the "Berini" uses the "flat-top" type of piston in conjunction with a rotary induction valve, this being a disc driven from the crankshaft and spring-loaded against the inner face of the crankcase. The cylinder is mounted in an inverted position, and the unit can be lifted out of contact with the tyre through the medium of a handlebar lever.

Maintaining the "Berini"

After 400 miles, the carburettor air filter should be removed and washed in petrol. Afterwards, it should be soaked in a mixture of two parts of oil to one of petrol and left overnight to allow any excess oil to drain away.

The silencer should be detached when 1,000 miles have been covered and the interior freed of carbon. At the same time, clean out the exhaust port. The decarbonising of the cylinder head and the piston crown can be deferred until 1,500 miles have been covered.

When the exhaust system has received attention, the carburettor and the air filter should both be cleaned in petrol and the filter soaked as before. The contact-breaker points should be checked and the gap between them reset, if necessary a drop of oil being applied to the felt pad on the contact breaker arm. All nuts and bolts should be given attention, tightening-up if required. The adjustment of the cable controlling the lifting of the unit should also be checked. The sparking plug should be removed and cleaned, and the gap between the electrodes checked. When this has been done, the engine should be

run until it is warm and the various engine nuts re-checked for tightness.

After 3,500 miles have been covered, it is possible that the float chamber needle and its seating may be in need of replacement. A new sparking plug may also be required as a result of the gradual burning away of the electrodes. Other parts which may need to be renewed are the two rubber bushes upon which the unit is suspended, these being fixed to the front fork support bracket. These tasks, should, of course, be repeated at the appropriate intervals throughout the unit's life.

Routine maintenance, which should be carried out fortnightly unless one's mileage is of a very low order, includes cleaning the sparking plug and re-gapping it; checking the various nuts and bolts—especially if the road surfaces are none too good—and oiling the cables. The engine lifting lever should, however, not be heavily oiled, as there is a danger that, if it is, the locking device may slip, with damage to the tyre as a result.

### The 45 c.c. "Cymota"

One of the first all-British units to appear, the "Cymota" gained immediate favour with the public. A front-wheel drive design, the "Cymota" is distinctive by reason of the full enclosure of the working parts in a neat cowling, which also incorporates a built-in headlamp. A carborundum-faced roller transmits the drive and the engine is a simple, three-port two-stroke, fitted with a deflector piston.

### Maintaining the "Cymota"

The first step in carrying out maintenance tasks on the "Cymota" is, of course, to remove the "bonnet". This is held in position by a fastener catch. When released, it allows the cowling to hinge forwards. The bonnet support wire should then be detached and the electrical plug—both wire and plug are fixed to the back-plate—detached. The cowling may then be lifted off its hinges.

The 45 c.c. "Cymota" features total enclosure and a built-in headlamp.

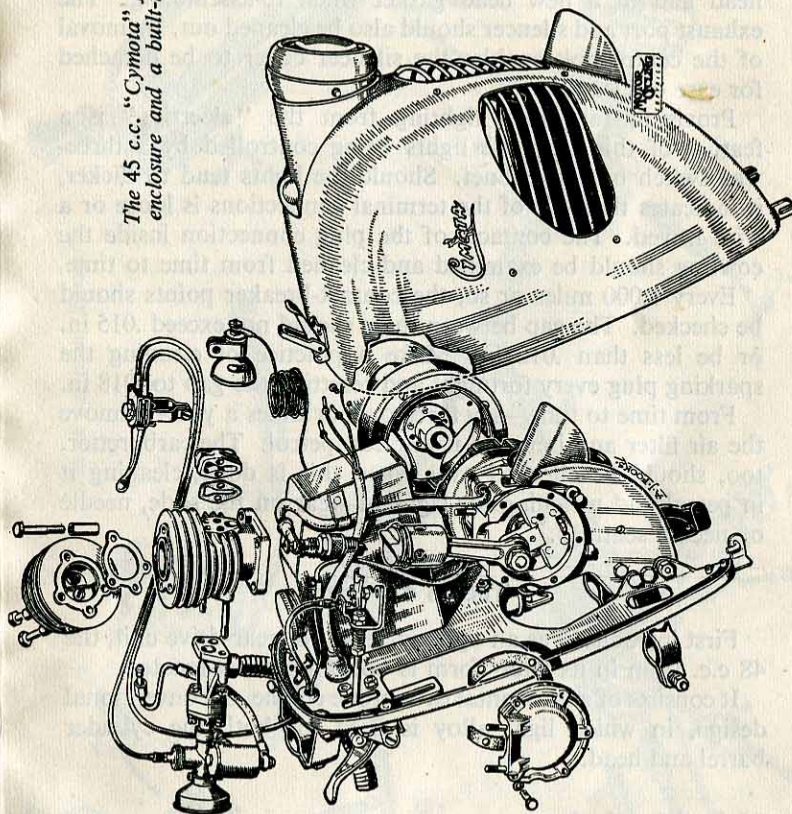

Decarbonising is recommended after every 2,000 miles have been covered. Having removed the sparking plug and disconnected the plug lead, the engine nuts are detached; the pull rod is then lifted and removed from the bracket. The cylinder head should next be lifted off. Clean the piston and head and fit a new head gasket when re-assembling. The exhaust port and silencer should also be cleaned out. Removal of the centre bolt enables the silencer cover to be detached for ease of cleaning.

Provision for direct lighting from the "electrics" is a feature of this unit, the lights being controlled by a three-way switch on the bonnet. Should the lights tend to flicker, it indicates that one of the terminal connections is loose or a wire frayed. The contacts of the plug connection inside the cowling should be examined and cleaned from time to time.

Every 1,000 miles or so, the contact-breaker points should be checked. The gap between them should not exceed .015 in. or be less than .012 in. Make a practice of cleaning the sparking plug every fortnight and resetting the gap to .018 in.

From time to time—say three or four times a year—remove the air filter and immerse it in clean petrol. The carburetter, too, should be checked over when this is done, cleaning it in petrol and watching for signs of wear on the slide, needle or needle seatings.

### The 48 c.c. Itom

First introduced as an optional front- or rear-drive unit, the 48 c.c. Itom in its latest form is bottom-bracket-located.

It consists of a horizontal two-stroke engine, of conventional design, in which light alloy is used for both the cylinder barrel and head.

### Maintaining the Itom

While the manufacturers warn against the owner of one of these units completely dismantling it, there is nothing complicated about the Itom and, provided the advice given in Chapter VI has been duly digested, the average user should

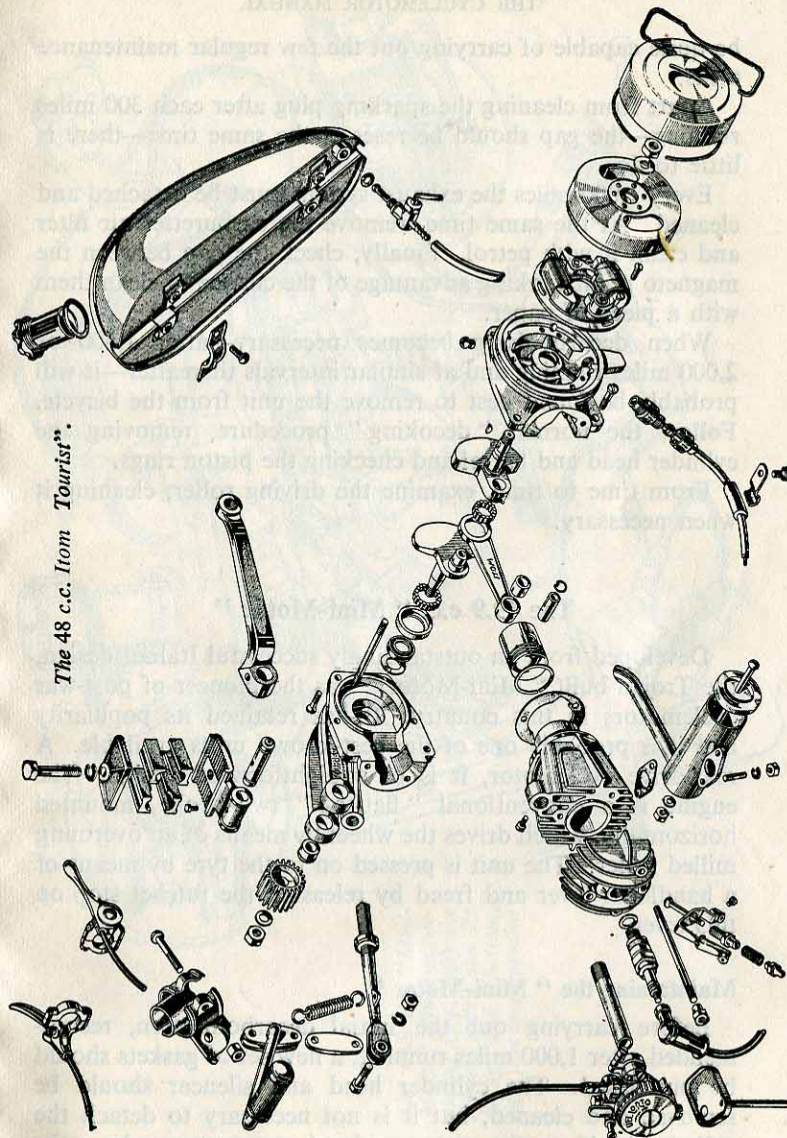

be quite capable of carrying out the few regular maintenance tasks.

Apart from cleaning the sparking plug after each 300 miles running—the gap should be reset at the same time—there is little to do.

Every 1,000 miles the exhaust system must be detached and cleaned. At the same time, remove the carburetter air filter and clean it with petrol. Finally, check the gap between the magneto points, taking advantage of the chance to clean them with a piece of paper.

When decarbonising becomes necessary—after 1,500 or 2,000 miles running and at similar intervals thereafter—it will probably be found best to remove the unit from the bicycle. Follow the normal “decoking” procedure, removing the cylinder head and barrel and checking the piston rings.

From time to time, examine the driving roller, cleaning it when necessary.

### The 49.9 c.c. “Mini-Motor”

Developed from an outstandingly successful Italian design, the Trojan-built “Mini-Motor” was the pioneer of post-war cyclemotors in this country. It has retained its popularity and it is probably one of the best-known units available. A rear-drive cyclemotor, it is of straightforward design. The engine is a conventional “flat-top” two-stroke, mounted horizontally, which drives the wheel by means of an overhung milled roller. The unit is pressed on to the tyre by means of a handlebar lever and freed by releasing the ratchet stop on this lever.

### Maintaining the “Mini-Motor”

Before carrying out the initial decarbonisation, recommended after 1,000 miles running, a new set of gaskets should be purchased. The cylinder head and silencer should be removed and cleaned, but it is not necessary to detach the cylinder itself, as the piston and exhaust port can be satis-

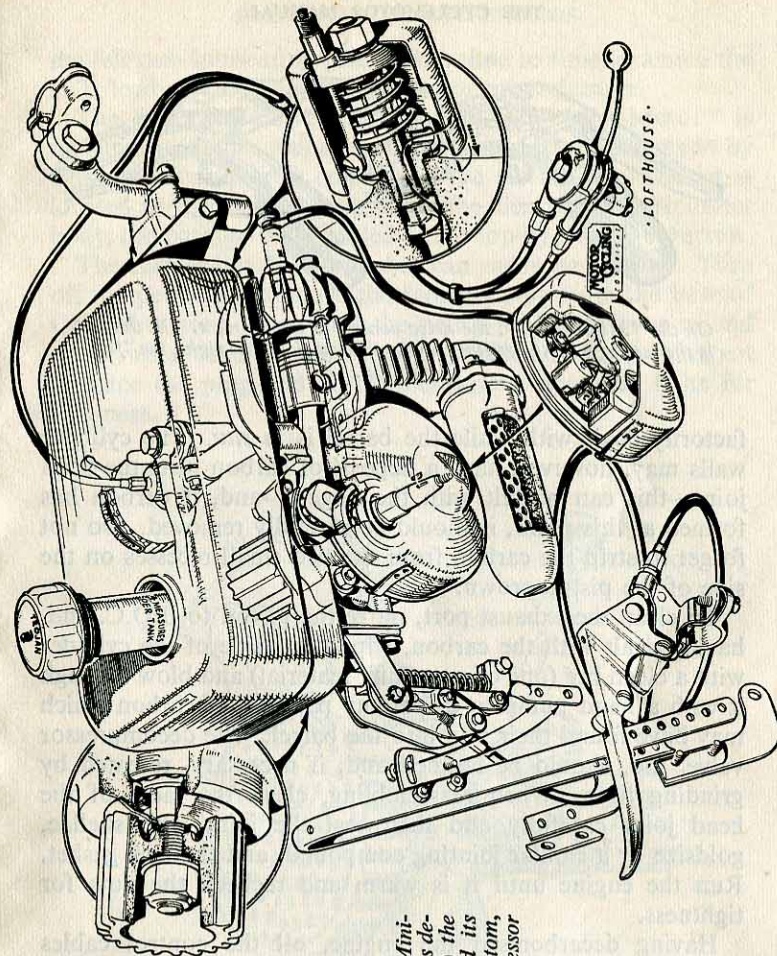

The 49.9 c.c. “Mini-Motor” with insets depicting (top, left) the driving roller and its fixing and (bottom, right) the decompressor

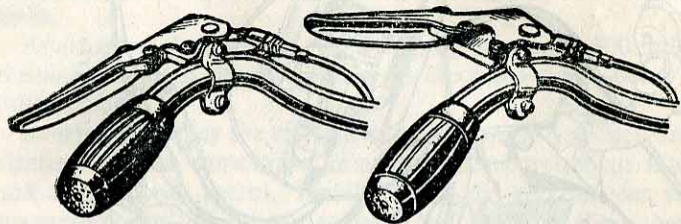

On the "Mini-Motor", the drive control is unorthodox. On the left is the setting with the engine driving the wheel; on the right, the "free" position.

factorily dealt with while the barrel is *in situ*. The cylinder walls may, however, have a deposit of carbon near the head joint—this can be felt with the fingers—and, if carbon has formed at this point, it should be carefully removed. Do not forget to strip the carbon from the two small recesses on the side of the piston crown.

To clean the exhaust port, move the piston to B.D.C. and, having dealt with the carbon, wipe the inside of the cylinder with a clean rag (one of non-fluffy material) and blow through it with a hand pump to dispel any particles of carbon which may have found their way into the barrel. The decompressor valve, too, should be cleaned and, if necessary, resealed by grinding it in. When reassembling, clean the faces of the head joint carefully and then seal the joint with shellac, goldsize or a similar jointing compound, and the new gasket. Run the engine until it is warm and recheck the nuts for tightness.

Having decarbonised the engine, oil the control cables and ascertain that the roller rests centrally on the tyre. Should it not do so, loosen the front bolt on the elbow lug and re-align the unit. Check, also, that the roller grooves are free from dirt.

Attention should then be given to the flywheel magneto. The contact-breaker points should be examined and cleaned. After 5,000 miles a few drops of thin oil can be used to moisten

the felt cam lubricating pad. From time to time, examine the H.T. lead and insulator for cracks or other damage.

The Dell'Orto carburetter fitted to the "Mini-Motor" is of simple design. Adjustments to the mixture are made by varying the rich-weak control on the air intake. The jet is located in the angled passage on the side of the carburetter body, the passage being sealed at the top by a small set screw.

The carburetter float chamber can easily be cleaned. Turn off the petrol and remove the screwed plug from the base of the carburetter. Then turn the petrol on again for a second or so, when the flow will dispel any sediment in the chamber. Replace the plug and check the various nuts and bolts for tightness.

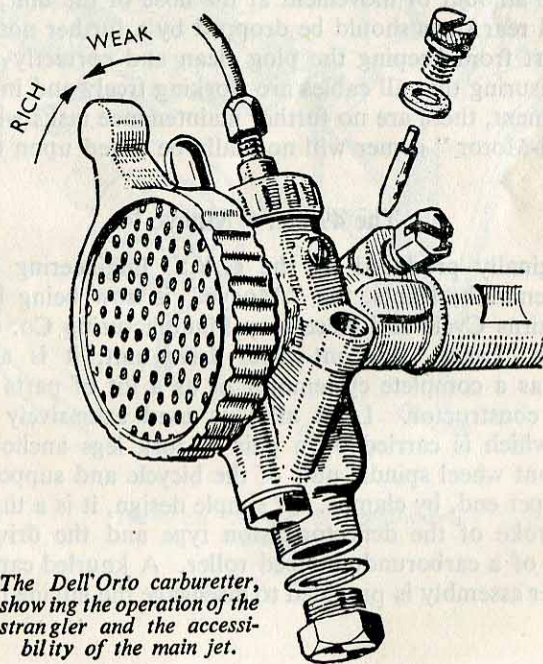

The Dell'Orto carburetter, showing the operation of the strangler and the accessibility of the main jet.

After 2,000 miles have been covered, the silencer should be dismantled and thoroughly cleaned. As the exhaust system is of light alloy construction, it should under no circumstances be immersed in the usual caustic soda solution for this purpose.

As was mentioned earlier, it is not usually necessary to disturb the cylinder barrel when decarbonising the engine, which task should be carried out every 1,000 miles. If it is removed, however, a new cylinder base gasket must be used when re-assembling.

It is important that adequate roller pressure is exerted on the tyre. Should the engine tend to race when accelerating abruptly, the pressure should be increased by loosening the front bolt on the elbow lug and sliding the front of the unit downwards, afterwards re-tightening the bolt. If this requires a large amount of movement at the nose of the unit, the U-shaped rear stays should be dropped by a further notch.

Apart from keeping the plug clean and correctly gapped, and ensuring that all cables are working freely and in correct adjustment, there are no further maintenance tasks which the "Mini-Motor" owner will normally be called upon to carry out.

### The 49 c.c. "Mocyc"

Originally produced by the G.Y.S. Engineering Co., of Bournemouth, Hants, the "Mocyc" is now being built by the Cairns Cycle and Accessory Manufacturing Co. of Todmorden, Lancs. A front-wheel drive unit, it is available either as a complete cyclemotor or as a kit of parts for the home constructor. Light alloy is used extensively in this unit, which is carried on a pair of fork legs anchoring on the front wheel spindle nuts of the bicycle and supported, at the upper end, by clamps. Of simple design, it is a three-port two-stroke of the deflector-piston type and the drive is by means of a carborundum-faced roller. A knurled cap on the shocker assembly is provided to disengage the engine from the tyre.

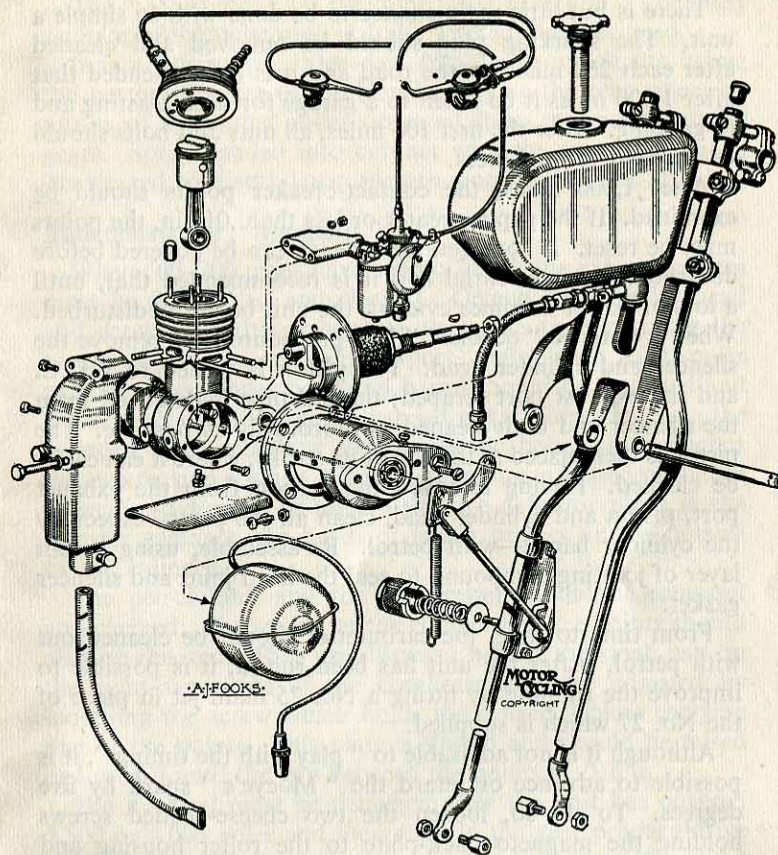

The 49 c.c. "Mocyc" is a front-wheel-drive unit.



**Maintaining the "Mocyc"**

There is but little maintenance to be done with so simple a unit. The sparking plug should be removed and cleaned after each 250 miles on the road and it is recommended that after 1,000 miles it be taken to a garage for sand-blasting and re-gapping. After the first 100 miles, all nuts and bolts should be checked for tightness.

After 1,000 miles, the contact-breaker points should be examined. If the gap is greater or less than .018 in. the points must be reset. A considerable mileage can be covered before decarbonising is essential and it is recommended that, until a loss of power becomes evident, the unit be left undisturbed. When it is to be "decoked", the procedure is to remove the silencer and cylinder head. The piston is turned to B.D.C. and the exhaust port scraped; the tail pipe is detached from the silencer and both cleaned as thoroughly as possible. The piston is then placed at the top of its stroke, where it can easily be cleaned. Having removed the carbon from the exhaust port, piston and cylinder head, clean all the parts—especially the cylinder barrel—with petrol. Re-assemble, using a thin layer of jointing compound to seal the head joint and silencer gasket.

From time to time, the carburetter should be cleaned out with petrol. After the unit has been run-in, it is possible to improve the running by fitting a No. 25 main jet in place of the No. 27 which is supplied.

Although it is not advisable to "play with the timing", it is possible to advance or retard the "Mocyc's" spark by five degrees. To do so, loosen the two cheese-headed screws holding the magneto back-plate to the roller housing and move the back-plate either clockwise or anti-clockwise to retard or advance the ignition.

Other routine points, which should be attended to at frequent intervals, include the checking of the various cables, which should also be kept well lubricated, and inflating the drive tyre hard at least once each week.

**The 38.5 c.c. "Mosquito"**

The "Mosquito" has for some years been one of the most popular of the units used in Italy, where it was designed.

It is a horizontal, three-port two-stroke which fits below the bottom bracket of the bicycle, driving the rear wheel by means of a serrated roller operated from the crankshaft by gears. Spring-loaded into contact with the tyre, the unit is disengaged by a stub lever operating on the bracket fitting.

**Maintaining the "Mosquito"**

When 600–700 miles have been covered, the exhaust system must be dismantled and cleaned. Detach the cylinder head and scrape off the carbon, at the same time cleaning the piston crown and the exhaust port. After each 2,000 miles running the cylinder head and barrel should be detached and a thorough decarbonisation carried out. When removing the cylinder, it is necessary to remove the bolts which anchor the two tension springs. When dismantling, no attempt should be made to remove or tighten the two deflector plugs in the transfer passages, the heads of which project on the outside of the cylinder.

The petrol tank and the carburetter should be removed and cleaned. The setting of the contact breaker points should also be checked. They are disposed behind the small cap on the right-hand side of the crankcase and are adjusted by loosening the screw which holds the "fixed" plate carrying one of the points. This plate is slotted and should be raised or lowered until the gap between the points is .016 in.

The flywheel must be detached after the unit has covered 3,500 or 4,000 miles and the grease in the gear primary drive checked by removing the gear cover. Should sediment be found, clean (but do not use detergents) and cover the gear teeth only with half an ounce of "Mobilgrease N.5". Replace the gear cover and rotate the drive roller until the marked tooth comes into line with the mark on the right-hand side of the aluminium roller support casing. It is permissible for the marked tooth to be located slightly below this mark, but it

should never be set above it. The flywheel may then be replaced with its engraved arrow in line with the arrow on the gear case, just below the "M" of "Mosquito". Once the marks coincide, the ignition timing—which may have been disturbed by the removal of the flywheel—will be correct. While none of these tasks should be beyond the ability of the average man with a fair mechanical knowledge, the makers advise that decarbonising and replenishment of the gear grease might best be entrusted to the agent from whom the unit was purchased.

Apart from the tasks mentioned above, there is but little routine maintenance which need be done. It is wise to remove the sparking plug after every 200 miles of motoring and to clean it thoroughly, resetting the spark gap to .020 in. Keep an eye, too, on the transmission roller and keep the grooves between the teeth free from road dirt. Make certain that the gap between the roller and the rear tyre, with the unit disengaged, does not exceed  $\frac{1}{8}$  in. Should it have increased, slide the unit back until the correct gap is again achieved. Before doing so, however, make certain that the tyre is well inflated and that neither of the tension springs has loosened or broken. Any of these defects can lead to roller slip, with resultant high tyre wear.

### The 49 c.c. "Power Pak"

Although, by reason of its inverted cylinder, this all-British unit has an unorthodox appearance, it is of extremely simple design. The "Power Pak" is a conventional, three-port two-stroke, employing a deflector piston. The drive is transmitted to the rear tyre by means of a milled roller and a control lever, operating in a gate, is used to engage or disengage the unit. Complete with the petrol tank and all necessary fittings, the "Power Pak" weighs 22 lb.

### Maintaining the "Power Pak"

After the first 250 miles have been covered—say after some four weeks' use—it is recommended that the magneto contact-

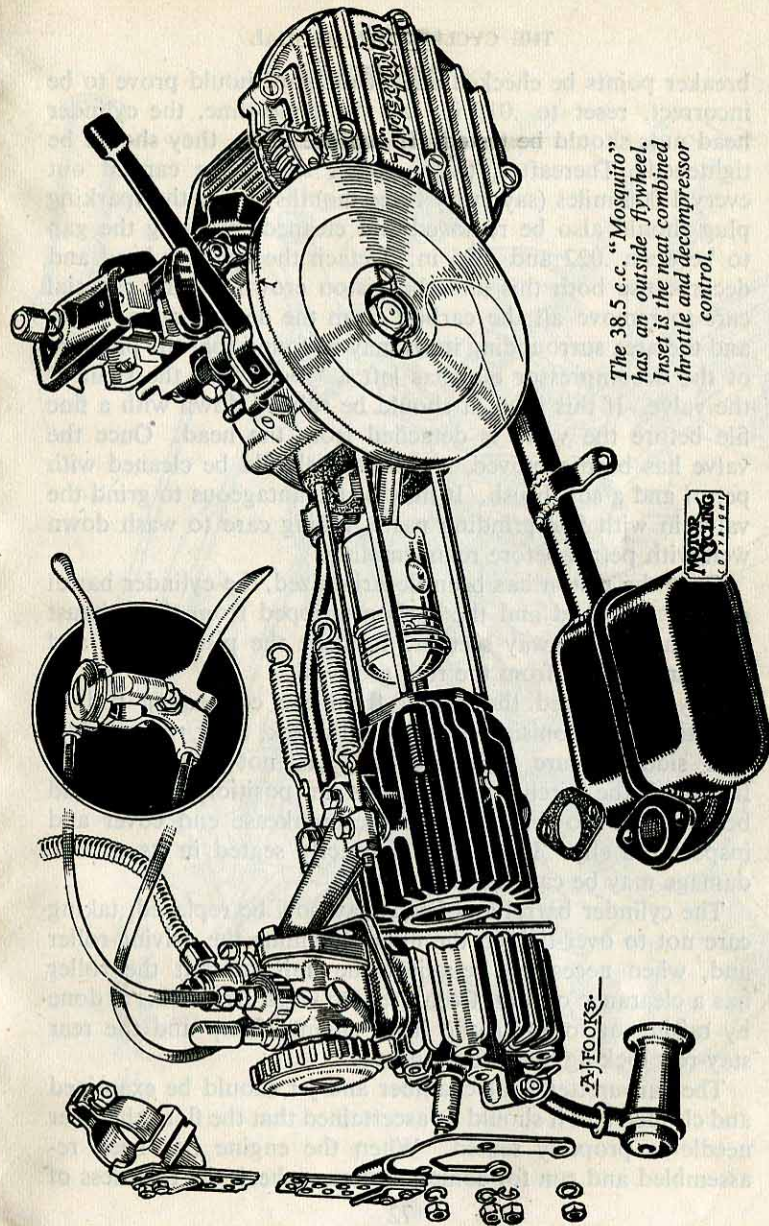

The 38.5 c.c. "Mosquito" has an outside flywheel. Inset is the neat combined throttle and decompressor control.

breaker points be checked and, if the gap should prove to be incorrect, reset to .015 in. At the same time, the cylinder head nuts should be tested. If any are loose, they should be tightened. Thereafter, these checks should be carried out every 1,000 miles (say every three months) when the sparking plug should also be removed and cleaned, resetting the gap to between .022 and .025 in. Detach the cylinder head and decarbonise both this and the piston crown, taking especial care to remove all the carbon from the decompressor valve and the area surrounding it. It may be found that the pressure of the decompressor clip has left a "burr" on the stem of the valve. If this is so, it should be rubbed down with a fine file before the valve is detached from the head. Once the valve has been removed, its seatings should be cleaned with petrol and a soft brush. It may be advantageous to grind the valve in with fine grinding paste, taking care to wash down well with petrol before re-assembling.

Once the piston has been decarbonized, the cylinder barrel may be detached and the carbon stripped from the exhaust port and its cutaway section. Remove the piston rings and strip any carbon from the ring grooves.

If you removed the piston from the connecting rod to facilitate decarbonising, you should check, after re-assembly, that side pressure from the rod has not mis-aligned or fractured the circlip which locks in position the big-end bearing. To do this, unscrew the crankcase end cover and inspect the clip. If it is not correctly seated in its groove damage may be caused.

The cylinder barrel and head may now be replaced, taking care not to over-tighten the nuts. Examine the driving-roller and, when necessary, re-adjust the unit so that the roller has a clearance of  $\frac{1}{8}$  in. from the tyre when free. This is done by raising or lowering the front engine clamp and the rear stay-rod locking and securing nuts.

The carburetter float chamber and jet should be examined and cleaned and it should be ascertained that the float chamber needle is properly seated. When the engine has been re-assembled and run for some minutes, recheck the tightness of

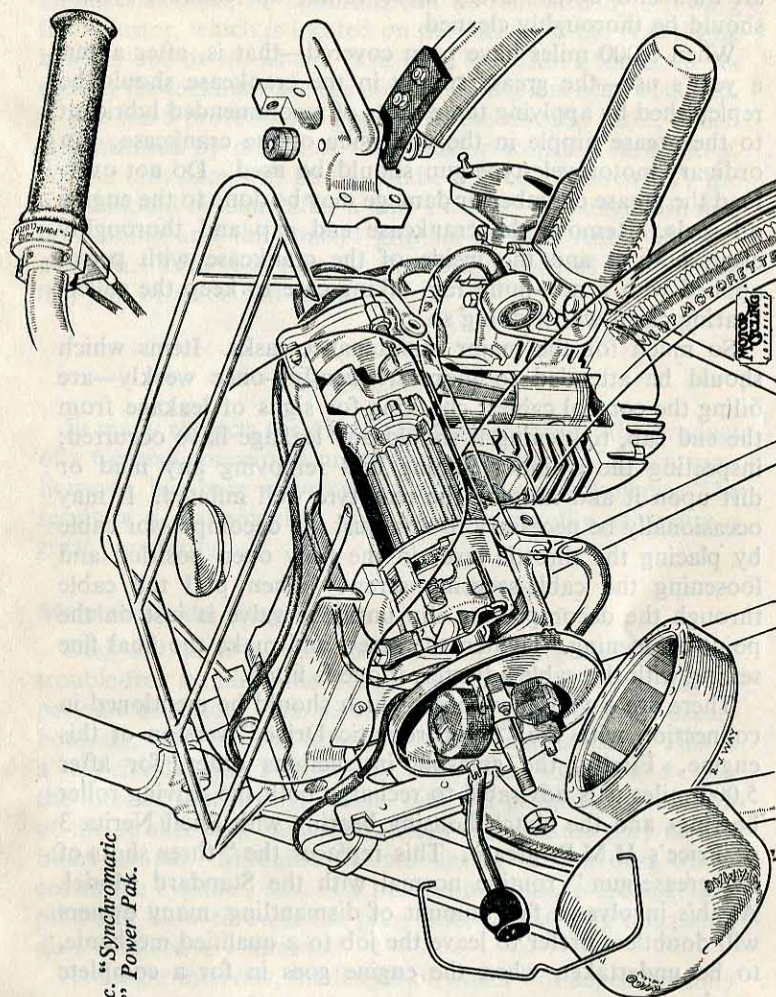

The 49 c.c. "Synchronomatic Drive" Power Pak.

all nuts and bolts. Every 2,000 miles, the exhaust system should be thoroughly cleaned.

When 5,000 miles have been covered—that is, after about a year's use—the grease supply in the crankcase should be replenished by applying three shots of recommended lubricant to the grease nipple in the underside of the crankcase. An ordinary motorcycle-type gun should be used. Do not overload the grease chamber or damage may be done to the engine oil seals. Remove the crankcase end cap and thoroughly clean both it and the inside of the crankcase with petrol applied with a non-fluffy rag, taking care to keep the roller-bearing clean whilst doing so.

So much for the major maintenance tasks. Items which should be attended to more frequently—once weekly—are oiling the control cables; checking for signs of leakage from the end cap, tightening it should any leakage have occurred; inspecting the cylinder finning and removing any mud or dirt upon it and keeping the rear tyre well inflated. It may occasionally be necessary to re-adjust the decompressor cable by placing the throttle lever in the fully open position and loosening the cable-securing screw. Then pull the cable through the decompressor clip until the valve is just on the point of opening. Tighten the screw and make the final fine setting with the cable adjuster, if one is fitted.

There are a very few points which should be mentioned in connection with the "Synchromatic Drive" version of this engine. Firstly, the greasing instructions differ, for after 5,000 miles it is advisable to recharge both the driving roller bearings and the clutch housing bearing with Shell Nerita 3 or Price's H.M.P. grease. This replaces the "three shots of the grease-gun" routine normal with the Standard Model. As this involves a fair amount of dismantling, many owners will doubtless prefer to leave the job to a qualified mechanic, to be undertaken when the engine goes in for a complete overhaul.

Clutch adjustment is simple. With the twistgrip control set in the "Power" position, there should be just a slight slackness in the cable, tested at the clutch operating lever end.

Undue slackness, or tightness, can be remedied by screwing the adjustor, which is located on the offside of the rear lifting handle, out or in, as the case may be. Don't forget to re-tighten the locknut once the correct setting has been obtained.

The same procedure is applied to the throttle cable, which is controlled by means of the adjustor atop the carburetter. As the aim here will be to obtain a good "tick-over", the work should be done after a mile's riding. The engine should be running and the control grip set in the "Auto Clutch" position. Take care that the machine is vertical when doing this job, or error will result.

### The 49 c.c. Teagle

In many respects the 49 c.c. Teagle two-stroke, the product of a Cornish concern, is unconventional. None of its features, however, has been incorporated without much thought. The result is a craftsmanlike unit which is steadily achieving a great popularity.

### Maintaining the Teagle

Designed, as it is, with the object of giving many miles of trouble-free running, the Teagle calls for little in the way of periodic attention. The most important job is that of decarbonising, with especial attention to the exhaust port. This is a very simple task. Periodically, remove the silencer and clean the interior thoroughly. Then, with the piston at the bottom of the stroke, chip the carbon from the exhaust port with a blunt scraper. Minimise the amount of carbon dust which enters the cylinder, and as a precaution remove the sparking plug and blow through the plug hole, so that any remaining dust is effectively removed.

At longer intervals, the length of which will depend mainly upon the nature of the job which your Teagle is called upon to do, the combustion chamber must be similarly treated. Before this can be done, the petrol tank and air cowling must be detached. This will leave the engine exposed for easy

working. Remove the cylinder head and, bringing the piston to T.D.C., scrape off the accumulated carbon.

Other routine jobs consist simply of inspecting the sparking plug and checking the gap (.022 in.); and verifying from time to time the gap between the contact breaker points. Here the manufacturer's advise a procedure rather different to that normally employed. It is a rather complicated method, which

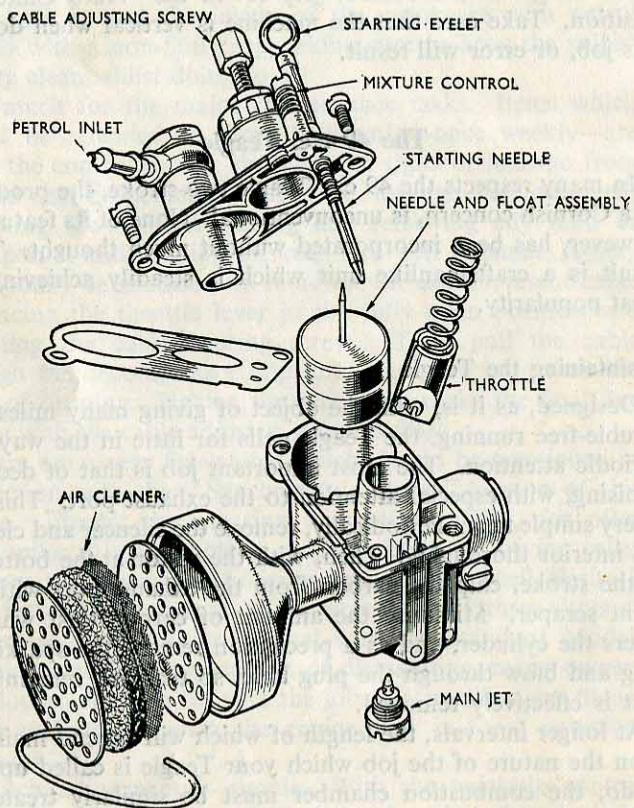

Internal details of the B.E.C. carburettor are clearly shown in this drawing.

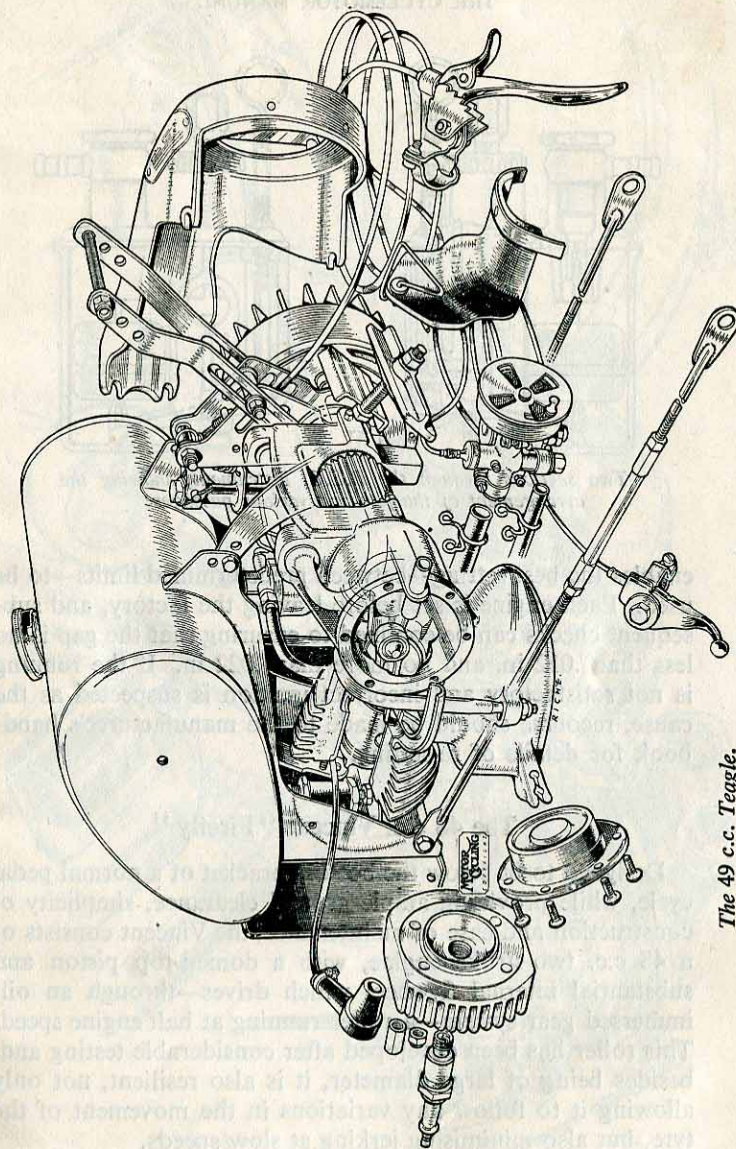

The 49 c.c. Teagle.

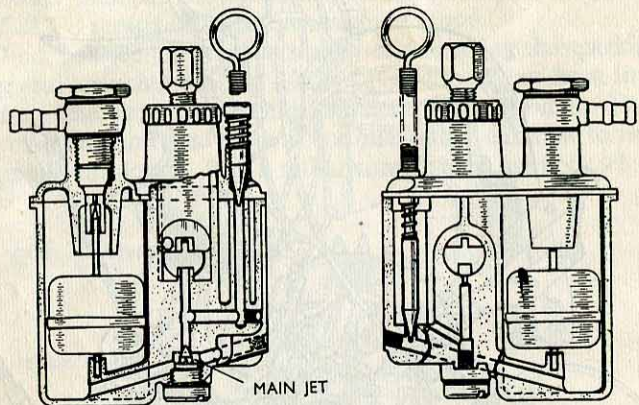

Two sections through the B.E.C. instrument, showing the arrangement of the jets and various passages.

enables the best setting—between predetermined limits—to be used. Each engine is set before leaving the factory, and subsequent checks can be confined to ensuring that the gap is no less than .012 in. and no more than .022 in. If the running is not satisfactory and incorrect ignition is suspected as the cause, recourse should be made to the manufacturer's hand-book for details of re-setting.

### The 48 c.c. Vincent "Firefly"

Designed to fit below the bottom bracket of a normal pedal cycle, while providing ample ground clearance, simplicity of construction and ease of maintenance, the Vincent consists of a 48 c.c. two-stroke engine, with a domed-top piston and substantial internal flywheel which drives—through an oil-immersed gear system—a roller running at half engine speed. This roller has been developed after considerable testing and, besides being of large diameter, it is also resilient, not only allowing it to follow any variations in the movement of the tyre, but also minimising jerking at slow speeds.

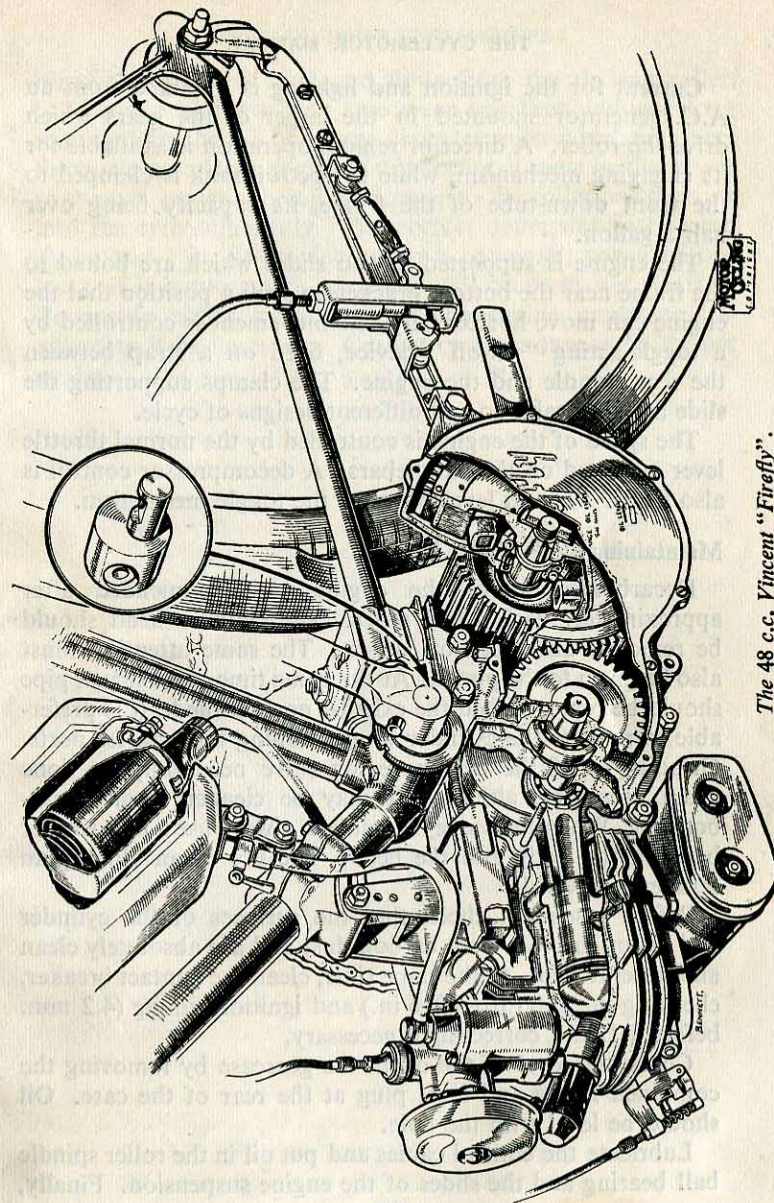

The 48 c.c. Vincent "Firefly".

Current for the ignition and lighting is obtained from an A.C. generator mounted in the larger of the gears which drive the roller. A direct or remote operation is available for its engaging mechanism, while the petrol tank is clamped to the front down-tube of the frame, its capacity being over half a gallon.

The engine is supported in two slides which are bolted to the frame near the bottom bracket, in such a position that the engine can move horizontally. Its movement is controlled by a toggle-acting "on-off" device, fixed on a strap between the rear spindle and the engine. The clamps supporting the slide are adjustable to suit different designs of cycle.

The speed of the engine is controlled by the normal throttle lever mounted on the handlebars. A decompressor control is also fitted. A hand lever operates the toggle mechanism.

#### Maintaining the " Firefly "

Decarbonisation of the engine is recommended after approximately each 2,000 miles. The cylinder head should be removed and freed of carbon. The same attention must also be given to the piston. At the same time, the exhaust pipe should be removed and the exhaust port cleaned. It is preferable to remove the cylinder when cleaning the transfer ports. Grinding-in of the decompressor valve need only be done when necessary, although it may be cleaned upon decarbonising. When the valve is removed, always use a new washer between the body and the head. The use of an aluminium scraper is advised.

Before assembly, check that the surfaces of the cylinder and piston are free from carbon dust and are absolutely clean and unscratched. At the same time, clean the contact breaker, checking the gap (.018-.016 in.) and ignition timing (4.2 mm. before T.D.C.), correcting if necessary.

Check the level of the oil in the gearcase by removing the combined filling and level plug at the rear of the case. Oil should be level with the hole.

Lubricate the control cables and put oil in the roller spindle ball bearing and the slides of the engine suspension. Finally,

remove any excess mud and flints from the driving roller.

Tyre slip and resulting tyre wear has been reduced to a minimum by the use of a large-diameter roller which embraces the tyre over a large angle. If slip occurs, it must be due either to the tyre pressure being too low or to the roller not pressing into the tyre sufficiently. The correct depression is between  $\frac{3}{16}$  in. and  $\frac{1}{4}$  in. If the depression is too great, power will be lost ; if it is too small, some slip will occur in wet weather. To rectify either trouble, check the engine mounting, re-adjusting it as necessary. Correct tyre pressure is 60 lb. per sq. in.

## CHAPTER IX

### POSITIVE-DRIVE CYCLEMOTORS

#### The 35 c.c. B.S.A. "Winged Wheel"

PRODUCED BY a division of one of Great Britain's largest and most progressive industrial concerns, the 35 c.c. B.S.A. "Winged Wheel" is a unit whose rise to popularity has been most marked.

In layout it is one of the neatest of all cyclemotors, being built into a rear wheel unit, with side shielding of clean design for the enlarged hub. An additional point, indicative of the careful design work which has gone into the engine, is the provision of an internal-expanding brake of no less than eight inches diameter, giving assured stopping power.

#### Maintaining the "Winged Wheel"

Thanks to careful initial design, there is but little in the way of routine maintenance which needs to be carried out—and even this need not occupy overmuch spare time, for the various components are accessibly placed.

Satisfactory engine performance depends to a considerable degree upon the efficiency of the sparking plug, and this component should be removed and inspected every 500 miles. Its condition readily indicates whether the carburation is correct or not. If it is, the points will be fairly clean. An over-rich mixture results in a sooty black deposit on the plug; a weak mixture will leave a light grey deposit.

Clean the plug thoroughly, and check that the gap between the points is not less than .015 in. and not more than .018 in. The only other electrical component which needs an occasional check is the contact breaker of the flywheel magneto. Here, again, the critical factor is the gap between the two contact points, which should be .018 in. when they are fully open. If there is any appreciable deviation from this figure, re-

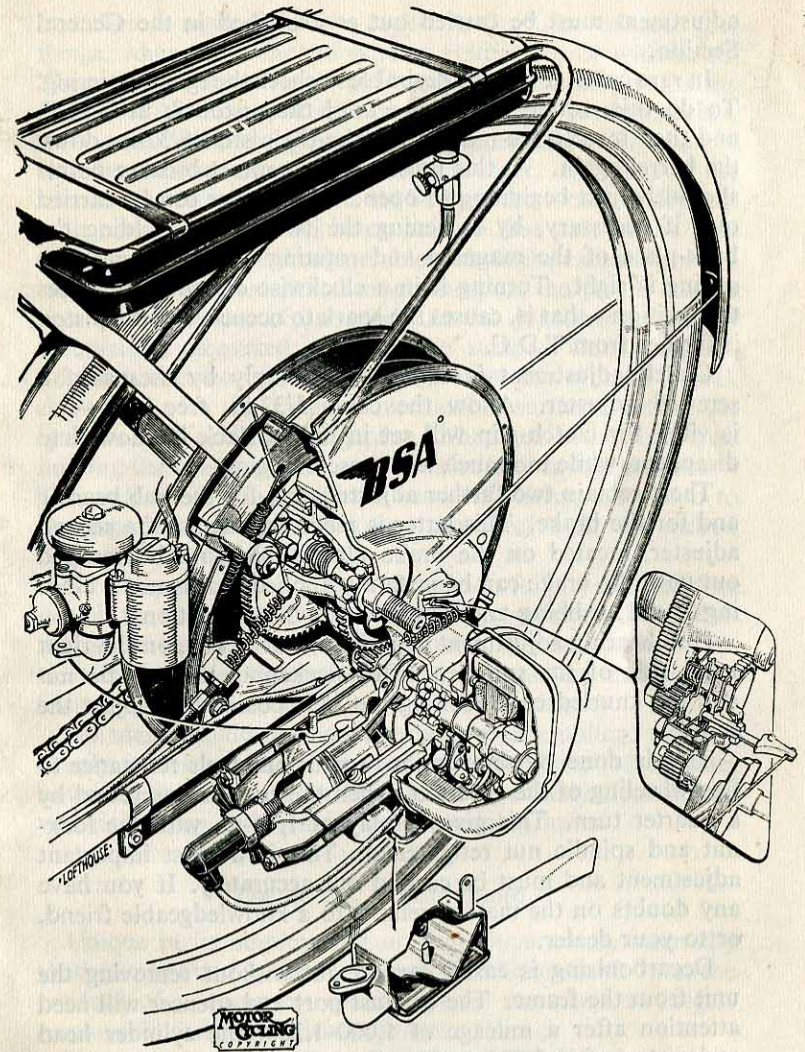

The 35 c.c. B.S.A. "Winged Wheel."



adjustment must be carried out as described in the General Section.

In rare cases, it may be desirable to check the ignition timing. To do this, rotate the engine until the piston is at T.D.C. and then reverse the motion to take the piston  $5/32$ -in. down the barrel again. At this juncture, the contact breaker points should be just beginning to open. Adjustment can be carried out, if necessary, by loosening the two screws holding the back-plate of the magneto and rotating the plate until the setting is right. Turning it in a clockwise direction advances the ignition—that is, causes the spark to occur when the piston is further from T.D.C.

Clutch adjustment is carried out simply by means of a screwed adjuster. Allow the cable  $3/32$ -in. free play—this is vital, for clutch slip will set in if this slack is allowed to disappear, while too much will cause dragging.

There remain two further adjustments—for the hub bearing and for the brake. This latter is made by means of a second adjuster, located on the brake plate. It should be screwed out until the brake can be instantly applied, but is not “binding”—i.e., rubbing under normal running conditions.

Hub bearing adjustment is limited to one cone, on the right hand side of the spindle. After slackening the spindle nut and the knurled cone locking nut it is possible to adjust the cone.

This is done by screwing it in until one feels resistance to free-wheeling of the sprocket, when the cone is unscrewed by a quarter turn. This gives a play of  $1/64$ -in. with the lock-nut and spindle nut retightened. This is a most important adjustment and must be carried out accurately. If you have any doubts on the matter, refer it to a knowledgeable friend, or to your dealer.

Decarbonising is easily carried out without removing the unit from the frame. The exhaust port and silencer will need attention after a mileage of 1,000–1,200; the cylinder head and piston after 2,000–2,400 miles.

First step is remove the exhaust pipe and silencer by slackening the crankcase nut which retains the slotted silencer clip,

and then removing the two lock-nuts from the exhaust port flange, when the complete exhaust system can be withdrawn. The removal of the single nut below the silencer permits the bottom of that component, complete with its sealing washer, to be removed, thereby baring the silencer baffle. This can in turn be removed simply by pulling it clear. All parts of the silencer and exhaust pipe should be freed from carbon deposit, with particular attention being paid to that part of the pipe which is nearest to the engine. Next clean the exhaust port by rotating the engine until through the port the piston can be seen at the bottom of its travel. At this juncture the port is completely uncovered, and can be scraped clean. Ensure, however, that no carbon chippings enter the cylinder barrel.

To deal with the combustion chamber surfaces, detach the ignition lead and sparking plug. Then undo the four nuts holding the cylinder head and remove the “saddle washers”. This will allow you to lift the head off. Bring the piston to the top of its stroke. You can now deal with the carbon deposit in the normal way.

Should you wish to inspect the piston fully, you must first detach the carburetter, which is held by two nuts. The cylinder barrel can then be gently removed. As the piston comes clear of the bore, support it so that it cannot be damaged by falling against some other part of the machinery.

No snags should be encountered in re-assembling, which is simply a reversal of the dismantling procedure. Make sure, however, that the cylinder head joint is perfectly clean before you tighten up the cylinder head retaining nuts.

### The 40 c.c. “Bantamoto”

Unique in its employment of gear drive to an internally toothed ring fitted to the rear wheel, the “Bantamoto” was the product of a company which, before the war, was largely responsible for popularising the autocycle.

Fitting to an extension of the rear spindle, the unit is carried on the left-hand side of the bicycle. It is a two-stroke, employing rotary valve induction.

### Maintaining the "Bantamoto"

Before the engine is run for the first time, remove the drain plug from the bottom of the gear case. Then detach the filler plug on the top of the casing and prime the case with one of the recommended oils until lubricant drips from the drain plug hole, when both plugs should be replaced. Excessive filling should be avoided, otherwise lubricant may seep into the magneto. From time to time the level of the oil should be checked by removing the drain plug, the case being topped up as required.

Before decarbonising, which should be undertaken every 1,500 miles or so, the engine must be removed from the frame.

To do this disconnect the cables and the fuel pipe and remove the wing nut holding the shock absorber to the chain stay of the bicycle. The unit should then be tilted upwards, thereby disengaging the buffer clip and allowing the engine to be drawn off the mounting centre. Decarbonising can now be commenced, following the procedure outlined in the chapter on "maintenance".

To replace the unit, slide it back onto the mounting centre and, if necessary, adjust the position of the driving sprocket relative to the gear ring by means of the spring-loaded alignment screw fitted to the centre. When the correct adjustment has been found—normally, of course, this will have been properly set when the unit was first fitted and it will not have been disturbed by the removal of the engine—insert the cotter pin to lock the screw. You may now connect the shock absorber by means of the clamp and wingnut and replace the control cables.

The magneto points will require checking and cleaning at regular intervals—once every six weeks or so. The correct gap is .018 in. At the same time the carburetter should be dismantled and cleaned, while the air filter should likewise be washed in petrol and soaked for a few hours in oil. However, remember that the filter must be allowed to drain out before re-assembling.

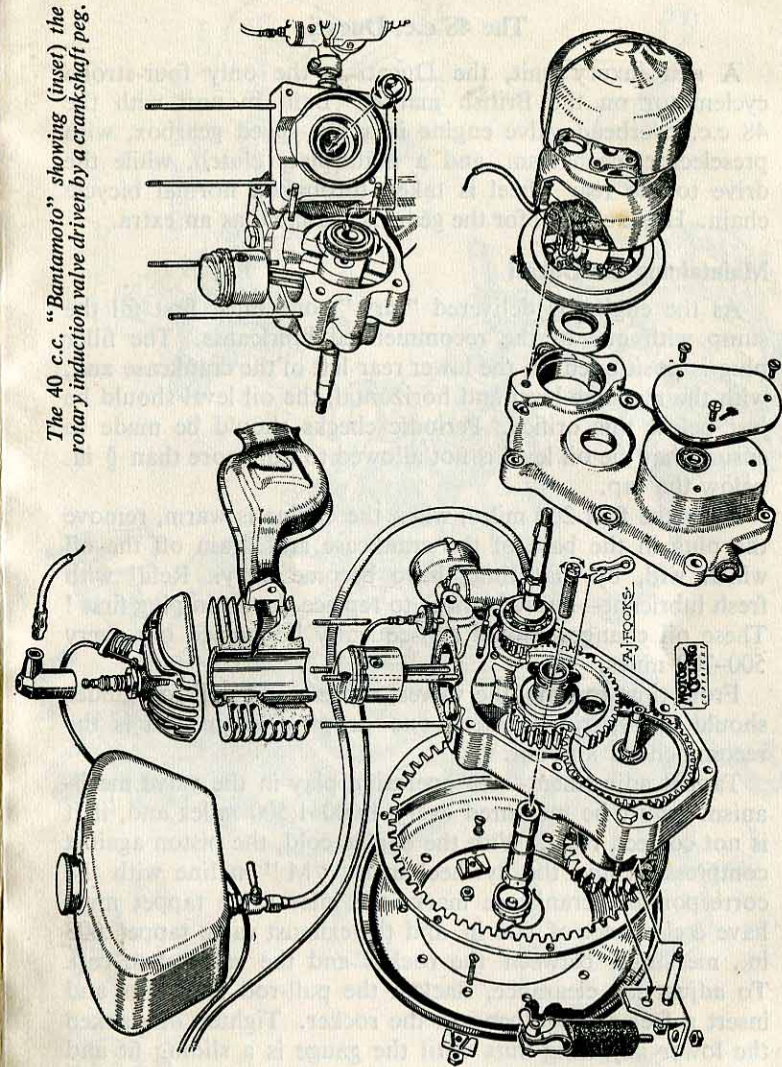

The 40 c.c. "Bantamoto" showing (inset) the rotary induction valve driven by a crankshaft peg.

### The 48 c.c. Ducati

A real luxury unit, the Ducati is the only four-stroke cyclemotor on the British market. Built in unit with the 48 c.c. overhead valve engine is a two-speed gearbox, with preselector mechanism, and a multi-plate clutch, while the drive to the rear wheel is taken through a normal bicycle chain. Hand control for the gears is available as an extra.

#### Maintaining the Ducati

As the engine is delivered "dry", one must first fill the sump with one of the recommended lubricants. The filler plug is positioned on the lower rear left of the crankcase and, with the machine level and horizontal, the oil level should be just below this orifice. Periodic checks should be made to ensure that the oil level is not allowed to fall more than  $\frac{3}{8}$  in. below the cap.

After the first 200 miles, when the engine is warm, remove the plug in the base of the crankcase and drain off the oil which will, by that time, have become dirty. Refill with fresh lubricant—but remember to replace the drain plug first! These oil changes should subsequently be carried out every 500–700 miles.

From time to time, the valves, rockers and pull-rod guides should be sparingly oiled—one drop of engine oil is the recommended amount.

Tappet adjustment—the operating play in the valve mechanism—must be measured every 1,000–1,500 miles and, if it is not correct, reset. With the engine cold, the piston against compression and the flywheel mark "M" in line with the corresponding crankcase mark, the inlet valve tappet must have a clearance of .006 in. and the exhaust valve tappet .003 in., measured between the rocker and the valve stem cap. To adjust the clearance, slacken the pull-rod lock nuts and insert a feeler gauge beneath the rocker. Tighten or slacken the lower adjusting nuts until the gauge is a sliding fit and retighten the locknuts, subsequently rechecking the gap.

When the tappets have been properly set, rotate the in-

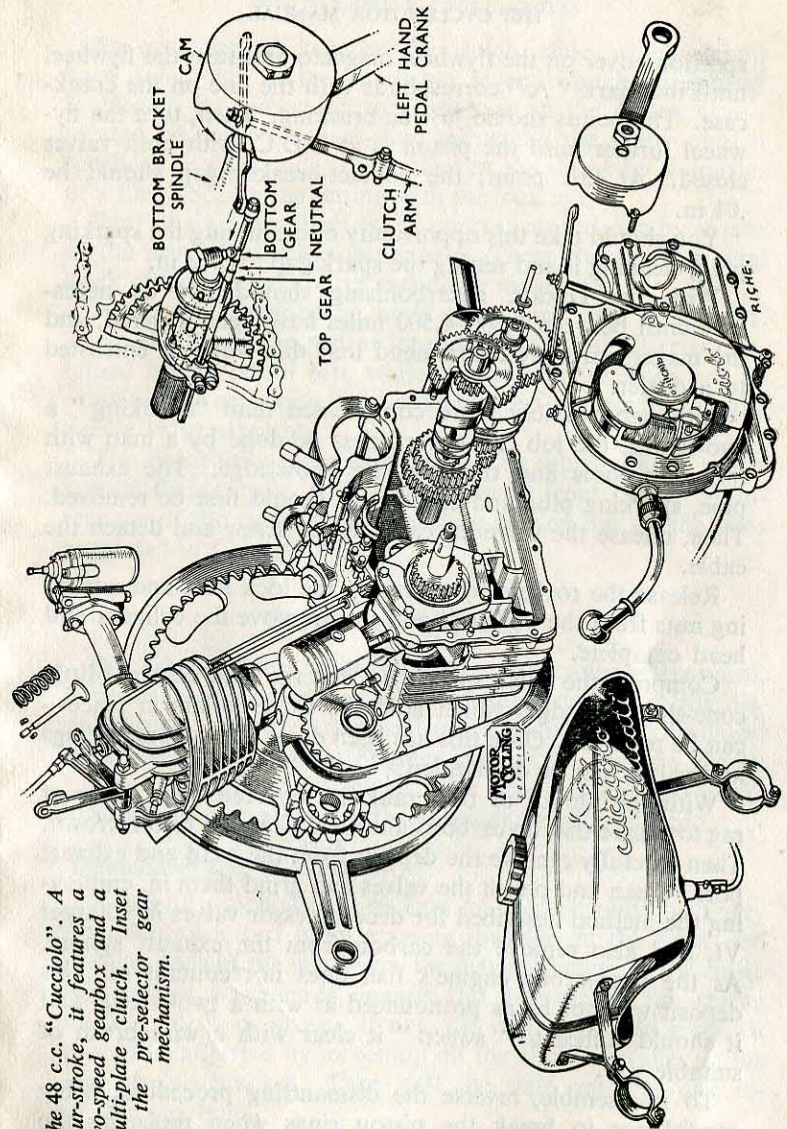

The 48 c.c. "Cucciolo". A four-stroke, it features a two-speed gearbox and a multi-plate clutch. Inset is the pre-selector gear mechanism.

spection cover on the flywheel magneto and turn the flywheel until the mark "A" corresponds with the line on the crankcase. The points should just be breaking. Then, turn the flywheel further until the piston is at T.D.C. with both valves closed. At this point, the contact-breaker gap should be .01 in.

You should take this opportunity of examining the sparking plug, cleaning it and setting the spark gap to .018 in.

With the Ducati, decarbonising should not be necessary until between 3,500-4,500 miles have been covered, and the makers strongly recommend that this work be entrusted to a dealer.

Although possibly more complicated than "decoking" a two-stroke, the job can nevertheless be done by a man with the right tools and the requisite knowledge. The exhaust pipe, sparking plug and carburetter should first be removed. Then, release the valve lift cable clamp screw and detach the cable.

Release the rockers by removing the lock nuts and adjusting nuts from the pull-rods and then remove the cylinder and head complete.

Compress the valve springs so that the split cotters—little cone-shaped wedges which hold the valve collars in place—can be removed. Once this has been done, the collars, springs and valves can be dismantled.

With the mouth of the crankcase covered by a piece of rag to ensure that no carbon can enter, clean the piston crown. Then carefully remove the deposit from the head and exhaust port. Clean and polish the valves and grind them in, employing the method described for decompressor valves in Chapter VI, and also remove the carbon from the exhaust system. As the four-stroke engine's fuel does not contain oil, this deposit will not be as pronounced as with a two-stroke, and it should suffice to "sweep" it clear with a wire brush of suitable size.

To re-assemble, reverse the dismantling procedure, being careful not to break the piston rings when replacing the cylinder. Finally, check the tappet adjustment.

An eye must be kept on the clutch cable, which should have  $\frac{1}{8}$  in. play at the handlebar lever. Clutch adjustment is effected by slackening the lock nut on the clutch arm—located on the crankcase—and tightening the screw until it touches the push rod. Then, slacken the screw by a quarter of a turn, locking the setting with the lock nut.

Rear chain adjustment is, of course, carried out by means of the normal bicycle components. There should be a total slack of half an inch of up and down movement.

Filters are provided on both petrol tank and carburetter. These should be cleaned at intervals. The tank filter is contained in the petrol tap, while the carburetter filter can be examined by removing the carburetter top and unscrewing the needle valve assembly.

This beautifully-engineered unit can be supplied fitted to the special Britax cycle, with rubber-sprung front forks. Maintenance of the cycle parts should be carried out on the lines suggested in Chapter VI.

### The 31 c.c. "Cyclaid"

Belt drive—which, as any old-time motorcyclist will confirm, is probably the smoothest of all positive drives—is the distinguishing feature of this well-made British unit. Produced by British Salmson Aero Engines Ltd., of 76 Victoria Street, London, S.W.1, the "Cyclaid" is a conventional two-stroke utilising die-cast alloy for the cylinder barrel and head.

#### Maintaining the "Cyclaid"

A careful watch should be kept on the belt tension. Every 200-300 miles, test it by pressing inwards on the front and rear portions of the belt below the driving-pulley. If the entire unit moves downwards against the pressure of the spring loading, all is in order. If not, the belt is too slack and it should be adjusted by loosening off the clamping bolts on the rear engine bracket. Then pull the unit upwards and retighten the bolts.

Every 300 miles the magneto and plug points should be

examined and the gaps—respectively .018 in. (.025 in. on engines up to serial number 700) and .020 in.—reset if necessary.

When decarbonising—the makers recommend that this work be done by a mechanic—detach the unit from the bicycle by removing both clamping screws from the rear engine bracket and then disconnecting the driving belt.

Next, unfix the decompressor cable at the engine—first setting its lever in the fully shut position—taking care not to lose the small ferrule which fits on the cable end.

The saddle pillar clamp bolt and washers are detached and the unit lifted off the bicycle. Now the petrol tank should be drained and the front engine plates, exhaust system, carburetter and sparking plug removed. The engine can then be decarbonised in the usual manner.

When re-assembling, merely reverse the above sequence. Note, however, that the paper gaskets must first be soaked in oil. After remounting the engine, run it for a spell and, while it is still hot, retighten the cylinder head nuts.

### The 25.7 c.c. and 32 c.c. "Cyclemaster"

Undoubtedly the most distinctive unit produced in this country, the "Cyclemaster" consists of an engine, with clutch and chain transmission, contained within the enlarged hub of a rear wheel. Since its introduction in 1950, it has become exceedingly popular by virtue of its compact design and the cleanliness inherent in its positioning.

The power unit is a conventional two-stroke fitted with a disc-type rotary valve controlling the induction. The latest models are of 32 c.c. capacity and have lighting coils in the flywheel magneto.

### Maintaining the "Cyclemaster"

The manufacturers recommend that the exterior of the engine and hub be cleaned weekly. At the same time, all nuts and bolts should be checked for tightness, particularly the locating bracket. Pressure in the rear tyre should be 45 lb.

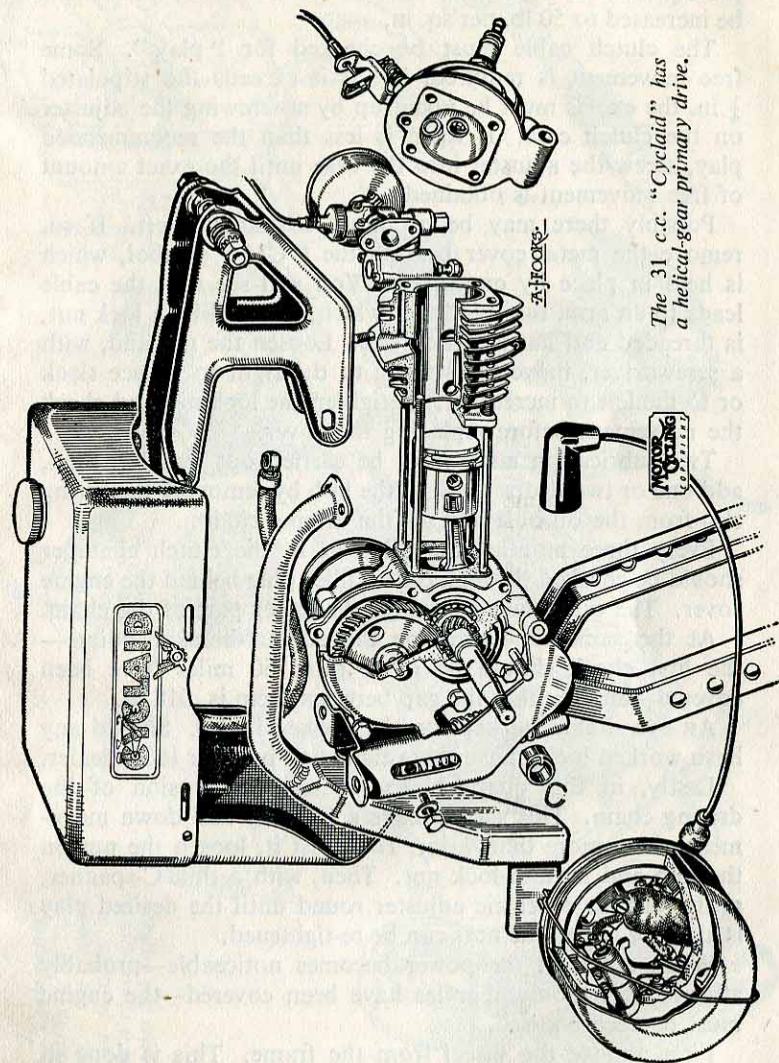

The 31 c.c. "Cyclaid" has a helical-gear primary drive.

per sq. in. and, if the rider scales over 12 stones, this should be increased to 50 lb. per sq. in.

The clutch cable must be checked for "play". Some free movement is required, but if it exceeds the stipulated  $\frac{1}{4}$  in. the excess must be taken up by unscrewing the adjuster on the clutch case. If there is less than the recommended play, screw the adjuster into the case until the exact amount of free movement is obtained.

Possibly there may be no more adjustment left. If so, remove the metal cover bearing the "CM" symbol, which is held in place by one screw. You will see that the cable leads to an arm, the spindle of which, retained by a lock nut, is threaded and has a slotted end. Loosen the nut and, with a screwdriver, move the spindle to the right to reduce slack or to the left to increase it. Retighten the lock nut and check the movement before replacing the cover.

Two lubrication tasks must be carried out weekly. First, add one or two drops of oil to the hub by removing the spring clip from the oil hole and oil the driving chain.

Every three months, the oil level in the clutch chamber should be checked through the oil filler plug behind the engine cover. The oil should just cover the lower part of the chain.

At the same time examine the contact-breaker points—the first check should be made after 50 miles have been covered—and see that the gap between them is .018 in.

An eye should be kept on the spoke nipples. Should any have worked loose, have them tightened by your local dealer.

Lastly, in this quarterly check, test the tension of the driving chain. This should have a total up and down movement of no more than  $\frac{1}{2}$  in. To adjust it, loosen the nut on the hub and its thin lock nut. Then, with a thin C-spanner, gently tap the eccentric adjuster round until the desired play is attained, when the nuts can be re-tightened.

When a fall in the power becomes noticeable—probably after several thousand miles have been covered—the engine must be decarbonised.

First remove the wheel from the frame. This is done in much the same way as with a normal bicycle, but you should

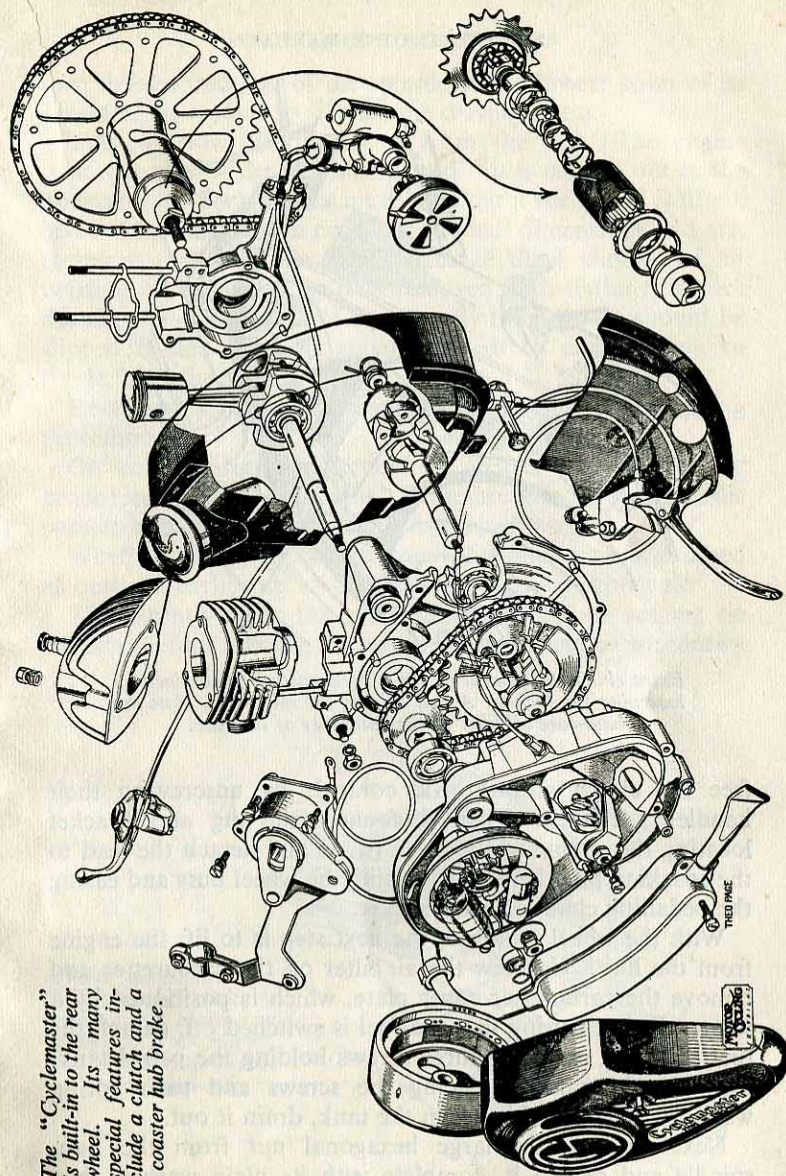

The "Cyclomotor" is built-in to the rear wheel. Its many special features include a clutch and a coaster hub brake.

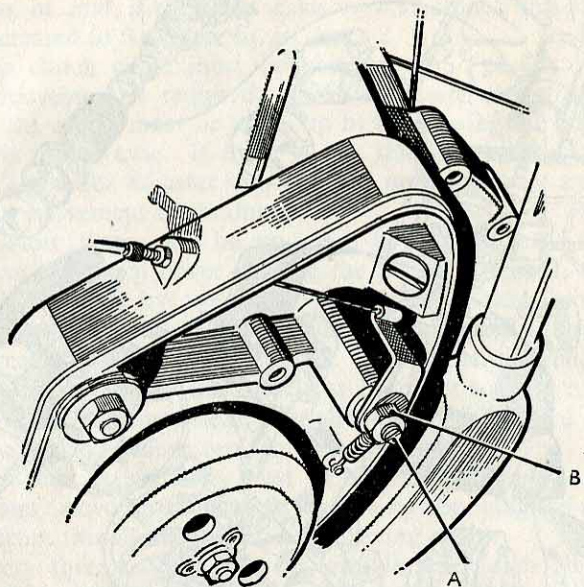

Extra clutch adjustment on the "Cyclemaster" is obtained by loosening the locknut A and turning the spindle B. Note the chain-case oil filler at the extremity of the case.

free the clutch and throttle controls by unscrewing their handlebar clamps. Then disconnect the lug and bracket locating the engine to the cycle frame and detach the lead to the sparking plug before slackening the wheel nuts and easing the pedalling chain off its sprocket.

With the wheel removed, the next step is to lift the engine from the hub. Unscrew the air filter on the carburetter and remove the carburetter cover plate, which is positioned by a screw. First ensuring that the fuel is switched off, detach the fuel pipe and undo the three screws holding the petrol tank. Lift out the tank, replacing the screws and their spring washers. If any fuel is left in the tank, drain it out.

Next unscrew the large hexagonal nut from the hub-spindle and detach it, complete with its plain washer, then

turn the squared end of the spindle to the lowest point of its eccentric movement to slacken the driving chain.

You can now lift the engine from the hub. The engine is now ready for decarbonizing, and this is carried out in the normal way. Special care must be taken if the barrel is lifted, however, for the piston rings are of small dimensions and are, therefore, delicate. To avoid damage there should be no twisting of the barrel as it is removed and, if the rings are detached, shims—strips of fractionally thin metal—should be slipped behind them at equal intervals to enable them to "ride" off the piston.

Re-assembly is simply a case of reversing the stripping procedure.

On units bearing serial numbers greater than 50,000, the procedure is slightly different. These are fitted with an Eadie coaster hub brake and have no free-wheel as such.

When removing the engine from these later wheels, proceed as outlined earlier up to the draining of the petrol tank.

Then, gently lever the long brake-arm off its seating on the cone before rotating the eccentric, which can be withdrawn

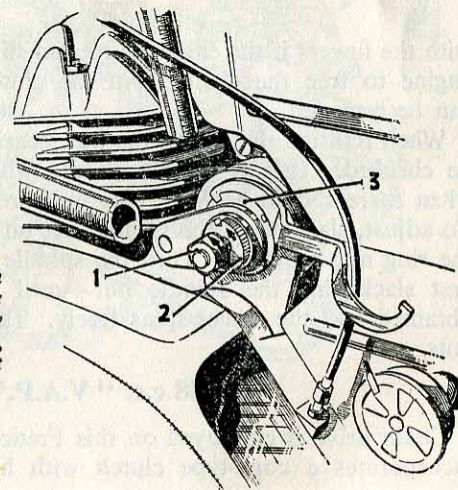

Chain adjustment on "Cyclemaster" units is effected, as shown, by means of a C-spanner, nut 1 and ring 2 first being loosened.

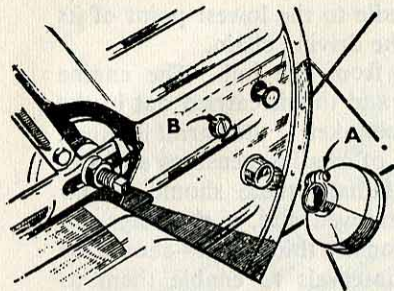

The Amal carburetter fitted to the "Cyclemaster" is easily detached. First, the air-filter A is removed and screw B loosened. Clip C holds the instrument to its stub, the fuel line being a push fit on the union D. The needle jet F is accessible upon removing the jet-well E.

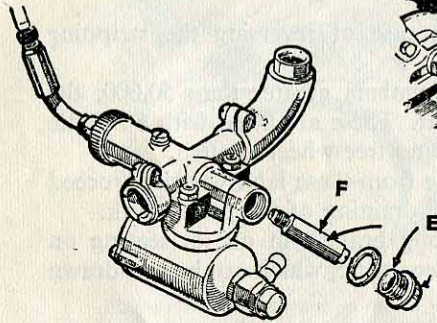
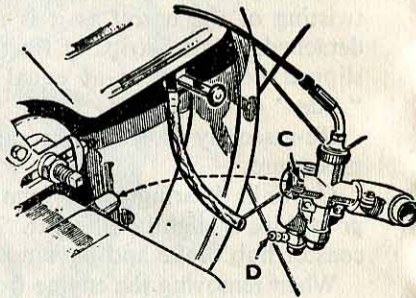

with the fingers if the engine is rocked slightly. By tilting the engine to free the chain from the clutchshaft sprocket, it can be removed.

When refitting the wheel, the hub bearing adjustment must be checked. This is done with the wheel off the ground, when there should be  $\frac{1}{64}$  in. play measured at the wheel rim. To adjust, slacken off the spindle nut on the engine side and the ring nut behind it. Turn the spindle on the drive side—first slackening the spindle nut—until the correct play is obtained and the wheel spins freely. Then retighten all the nuts.

### The 48 c.c. "V.A.P."

Chain drive is employed on this French two-stroke, which incorporates a cone-type clutch with helical gear primary

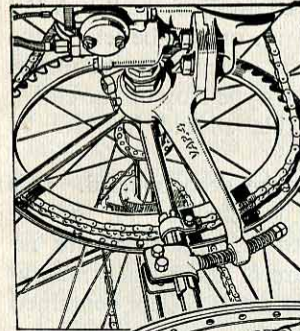

The 48 c.c. "V.A.P." features a cone clutch and chain drive.

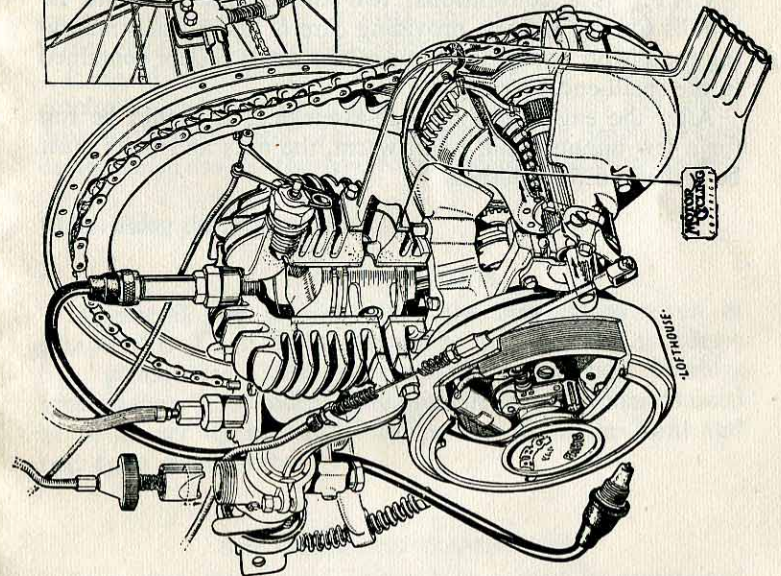



drive. It is designed to fit on the near-side of the rear wheel, and is carried on a pivoting arm with a spring shock absorber.

### Maintaining the "V.A.P."

Apart from the usual periodic check of the gaps between the contact-breaker points and the sparking-plug points, there is little routine maintenance work to be done on the "V.A.P."

It is important that some play— $\frac{1}{8}$  in. or so—be left in the clutch cable to ensure that the two cones mate properly. Adjustment is provided for by a screw-type stop on the clutch lever. Periodic greasing of the cable should likewise be ensured.

After 2,000 miles, the unit should be decarbonised. This is carried out exactly as described in Chapter VI, for the "V.A.P." is a conventional two-stroke, and there are no pitfalls for the unwary, providing care is taken when removing the piston not to lose any of the small rollers contained in the small-end bearing.

After the engine has been re-assembled, it should be run for a few minutes and, when warm, the nuts and bolts must be rechecked for tightness.

### The 49 c.c. "Mobylette"

ALTHOUGH THE "Mobylette" is sold as a complete machine and, as such, might be argued to be an autocycle and, consequently, beyond the scope of this volume, it has been included on the quite logical reckoning that it is designed to give cyclemotor performance and economy and that it is more comparable with the motor-assisted bicycle than with the heavier and more powerful autocycle. In other words, it is a cyclemotor built into a strengthened-up bicycle-type frame, rather than a pedal-assisted lightweight motorcycle.

Powered by a 49 c.c. two-stroke engine, the "Mobylette" employs V-belt primary drive to a countershaft and chain drive to the rear wheel. The countershaft has a simple locking device which enables the drive to be disconnected for pedalling.

### Maintaining the "Mobylette"

#### THE BICYCLE PARTS

In general you should follow the instructions given in Chapter VI. The front hub should be refilled with Castrolase light grease every 3,000 miles and the pedal crank bearings greased every 1,500 miles. Tyre pressures should be maintained at 14 lb. per sq. in. and 17 lb. per sq. in. in the front and rear tyres respectively.

#### THE ENGINE AND TRANSMISSION

Some free movement—about  $\frac{1}{12}$  in.—must be maintained in the decompressor cable and the twist grip must be so adjusted that the throttle is fully closed before the decompressor valve opens.

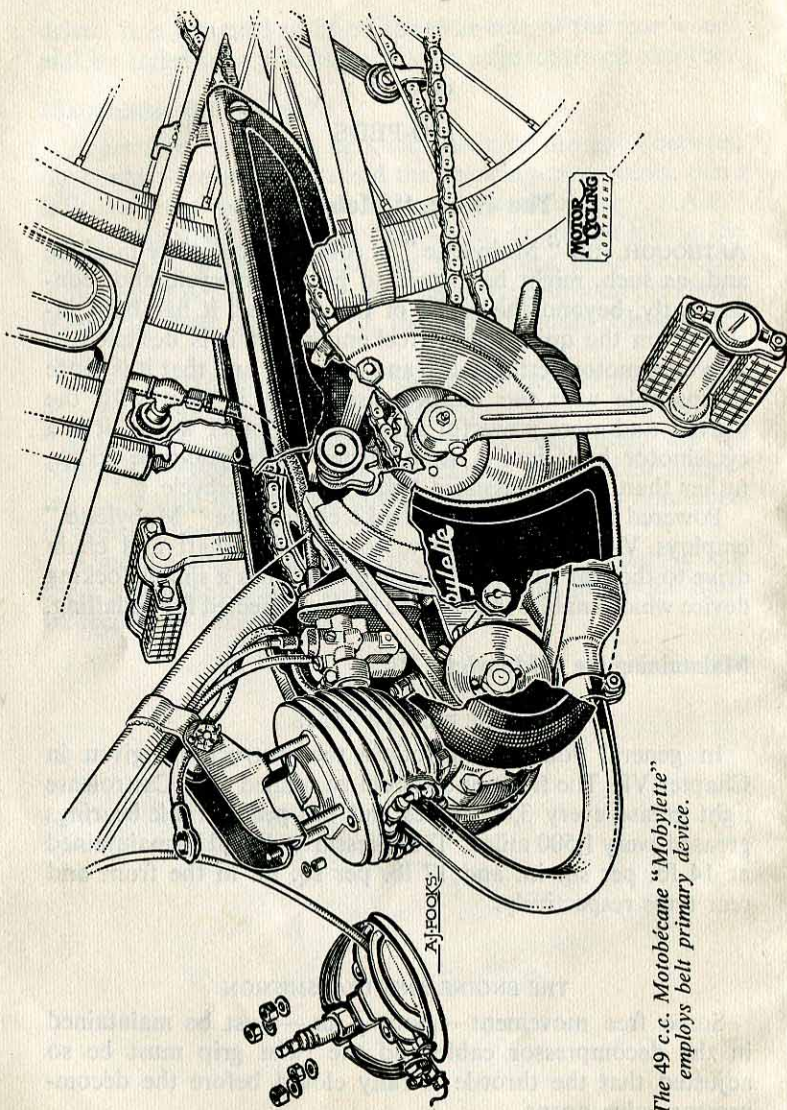

The 49 c.c. Motobécane "Mobylette" employs belt primary device.

The contact-breaker points must be inspected at regular intervals and the gap—.015 in.—checked. To examine the points, loosen the central nut on the flywheel. This has a left-handed thread, so to loosen you must turn it to the right. Before it can be turned, you will have to bend the lock washer which is engaged on the nut. Remove the flywheel and the points are readily accessible. At the same time, moisten the felt lubricating pad on the cam with a few drops of thin oil.

After each 1,500 miles the engine will require decarbonising, although the exhaust system need only be decarbonised every 4,500 miles after the first cleaning. As the "Mobylette" is quite a conventional machine, the procedure to adopt is that described earlier in the book.

Routine tasks include occasional cleaning of the filters in the tap and the carburetter and keeping the belt and chains in correct tension.

To tighten the belt, loosen the bolts which hold the engine to the frame and swing the unit about the upper bolt. Tighten the bolts again and lock them in place with split pins. The chain is adjusted in the normal way by pulling back the rear wheel. While this is being done, the tension arm on the pedalling chain should be loosened. This will automatically re-tension it.

### The 49 c.c. N.S.U. "Quickly"

Probably the world's most popular light autocycle, with an annual production nearing the 130,000 mark, the N.S.U. "Quickly" is typical of modern practice in this field. The frame is of pressed steel, and uses the beam principle; the two-stroke engine has a two-speed gear and clutch in unit, and transmits its drive through a chain. Spring forks are fitted at the front, and internal-expanding brakes are used.

### Maintaining the "Quickly"

#### THE BICYCLE PARTS

Designed for long service with the minimum attention the cycle parts make little claim on the owner's time. Periodically,

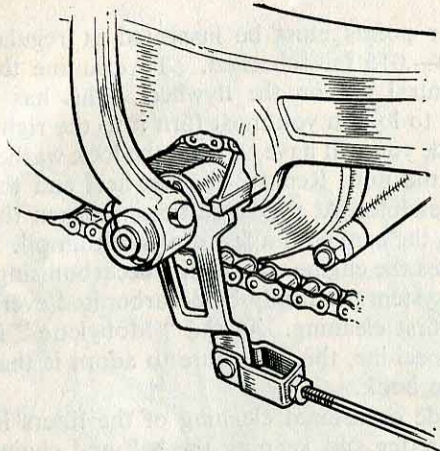

*The linkage, for the back-peddalling rear brake, which should periodically be lubricated.*

and particularly if the weather is bad for a prolonged spell, it is a good idea to give a shot of grease to all the grease nipples—after ensuring that the nipples themselves are clean. The chain drive should never be allowed to run dry, and every 300 miles one or two shots of the grease gun should be directed into the nipples on the pivot points of the front fork swinging links.

After 600 miles, take off the chain and clean it with petrol or paraffin. Then lay it in a tray of warmed grease, and swish it to and fro, removing it before the grease has set. Drain off any surplus, and re-fit to the machine.

While the chain is draining, one can improve the shining hour by greasing the pivot points of the brake rod. On every other occasion—i.e., every 1,200 miles—a little gearbox oil can be used to lubricate the bearing surfaces of such fitments as the handlebar levers and the saddle pivot. At this mileage, too, the Bowden cables should be detached and oil dripped through the casings. It is a good idea to grease the exposed section of the cable.

There remain three other routine tasks—lubricating the pedal bearings at 2,500 miles; the interior of the throttle and gearchange twist grips every 5,000 miles and re-packing the

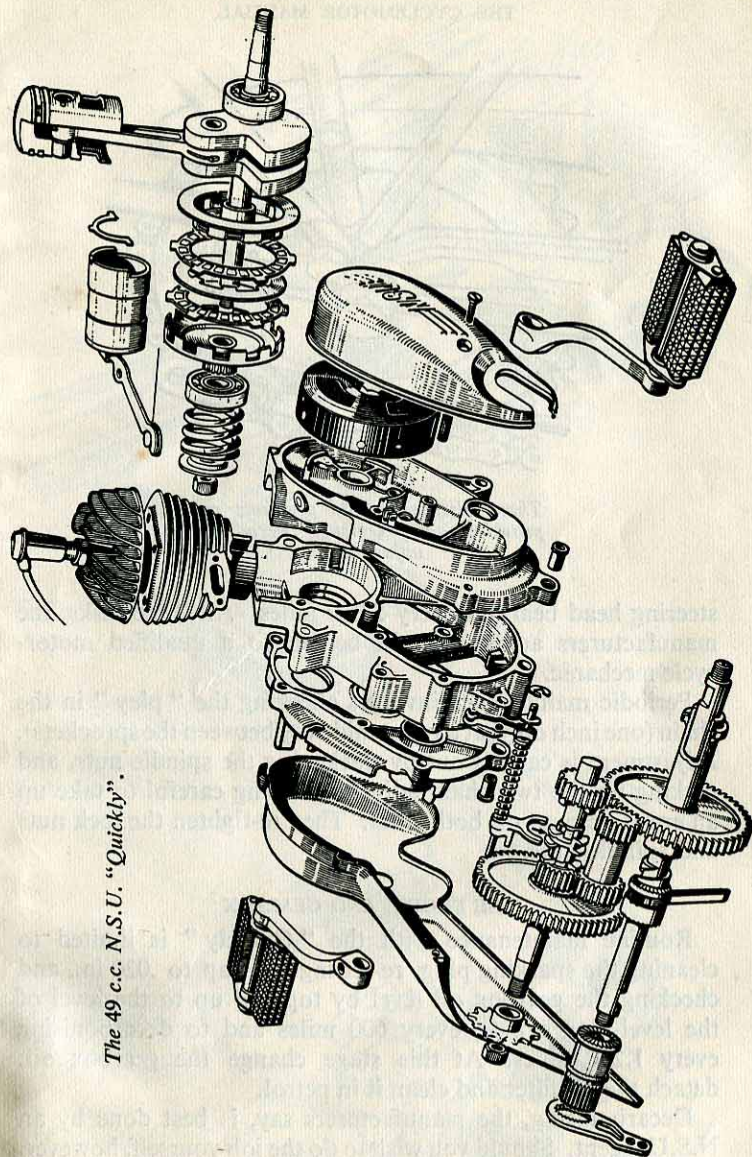

*The 49 c.c. N.S.U. "Quickly".*

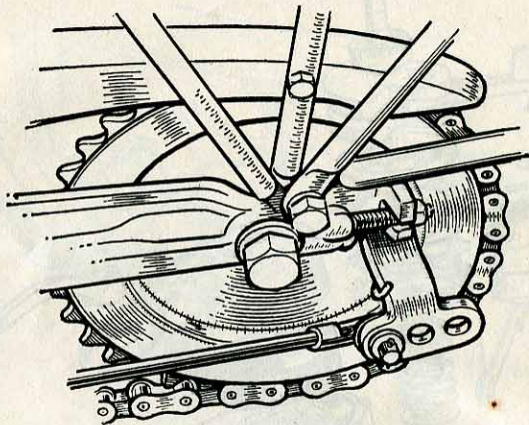

*Three alternative rod positions are provided on the "Quickly", permitting adjustment*

steering head bearings every 5,000 miles. All three tasks, the manufacturers advise, should be left to a qualified motor-cycle mechanic.

Periodic maintenance involves checking the "play" in the chain (one inch only, at a point mid-way between the sprockets). Adjustment is carried out by slackening the spindle nuts, and racking up the two chain adjusters—being careful to take up an equal amount on both sides. Then re-tighten the lock nuts and spindle nuts.

#### THE ENGINE AND GEARBOX

Routine maintenance with the "Quickly" is limited to cleaning the sparking plug, re-setting the gap to .020 in., and checking the gearbox oil level by topping up to the level of the level-plug orifice, every 600 miles and to decarbonising every 1,200 miles. At this stage change the gearbox oil: detach the air filter and clean it in petrol.

Decarbonising, the manufacturers say, is best done by an N.S.U. agent. Should you wish to do the job yourself, however,

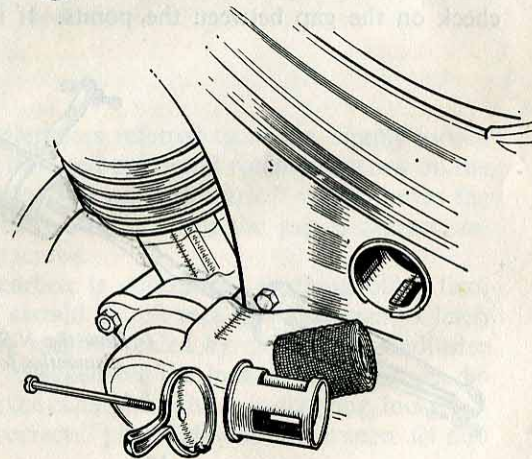
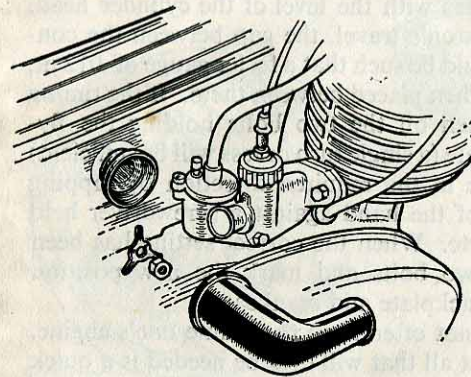
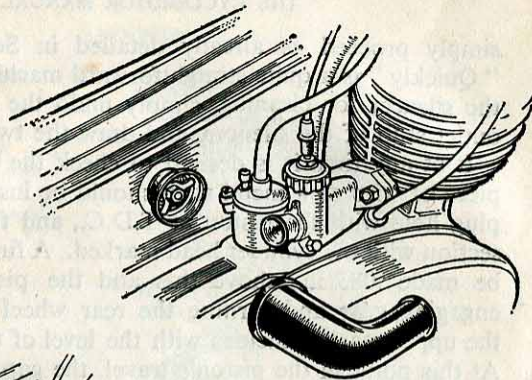

*Three stages in the removal of the "Quickly's" air filter, which is built in the frame.*

simply proceed as already detailed in Section 1, for the "Quickly" is a quite straightforward machine. To dismantle the silencer for cleaning, simply undo the centre nut in the outlet stub of the silencer, and draw the two halves apart.

If at any time it is desired to check the ignition timing, a piece of wire or a metal strip should be inserted through the plug hole with the piston at T.D.C., and the point of intersection with the cylinder head marked. A further mark should be made .083 in. above this and the piston lowered (by engaging gear and turning the rear wheel *backwards*) until the upper mark coincides with the level of the cylinder head. At this point in the piston's travel, the gap between the contact breaker points should be such that a feeler gauge of .012 in. to .016 in. is just free when placed between them. If the timing proves incorrect, slacken off the two bolts holding the fly-wheel magneto back-plate (a single turn or less will be sufficient) and turn the backplate in the required direction by tapping gently with the palm of the hand against a screwdriver held in contact with the plate. When the correct setting has been found, retighten the two bolts and mark the new position with a scribe on the backplate and crankcase.

Naturally, one does not often have to re-time one's engine. It is far more likely that all that will ever be needed is a quick check on the gap between the points. If it is less than, or

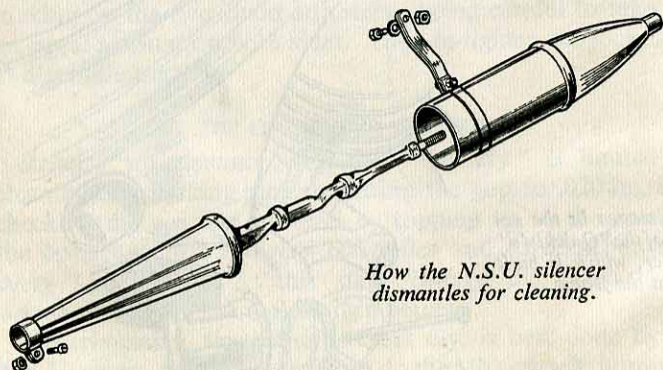

*How the N.S.U. silencer dismantles for cleaning.*

MO-PEDS

*The Bosch ignition and lighting equipment which is common to the N.S.U. and Zündapp "mo-peds".*

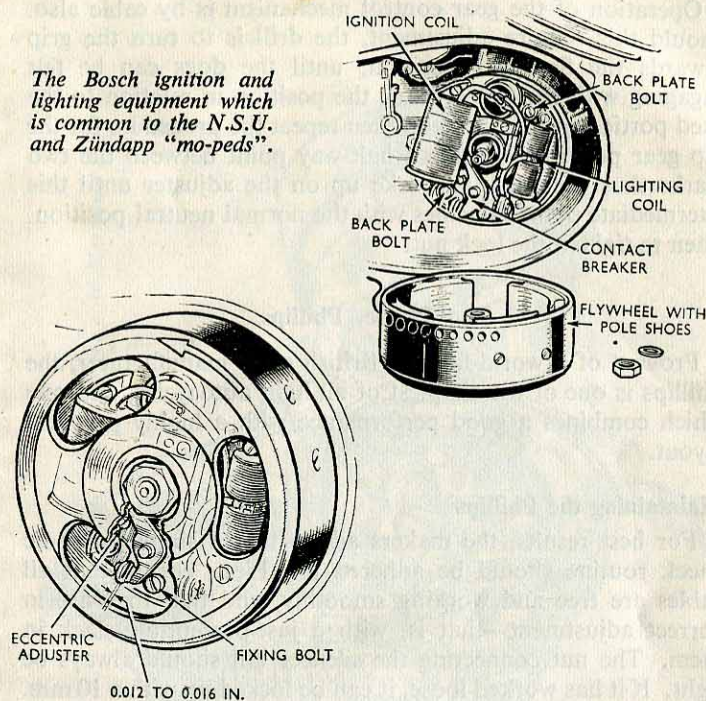

greater than, the tolerances referred to above, simply loosen the screws holding the fixed point and rotate the screw on the base holder. This operates an "eccentric" which moves the points relative to each other. When the gap is correct, retighten the holding screws.

So far as the gearbox is concerned, anything other than minor adjustments should be left to a qualified man. Clutch slip and clutch drag can be tackled by means of the adjuster on the handlebar. Slacken off the lock-nut, and rotate the adjuster, tightening the cable if the clutch is dragging, loosening it if it slips. The correct "play" should be between .04 and .06 in.

Operation of the gear control mechanism is by cable also. Should this require adjustment, the drill is to turn the grip towards the first-gear position, until the dogs can be felt engaging with the gear. Mark the position in relation to the fixed portion of the grip, and then repeat the procedure for the top gear position. Locate a half-way point between the two marks thus obtained, and take up on the adjuster until this intermediate point coincides with the normal neutral position. Then re-tighten the lock nut.

### The 49 c.c. Phillips

Product of a world-famous British cycle manufacturer, the Phillips is one of the simplest of all light autocycles, and one which combines a good performance with a highly practical layout.

#### Maintaining the Phillips

For best results, the makers advise that a simple periodic check routine should be adhered to. First, ensure that all cables are free and working smoothly, and that they are in correct adjustment—that is, with a just-perceptible slack in them. The nut connecting the silencer tail should always be tight. If it has worked loose, it can be locked up with a 10 mm. spanner, and the split pin should be replaced and spread out. Every 600/900 miles, the exhaust pipe should be detached and decarbonised. It is held in place by two nuts. Undo these, pull off the pipe, and chip out the carbon. At the same time, clean the exhaust port in the cylinder and, if the joint gasket is damaged, put in a new one. Another point to check is the condition of the air filter on the carburetter. Removing one screw frees the filter, which should be washed in petrol and bathed in oil. Allow it to drain, and then replace it. Small fuel filters are located in the carburetter tap and in the fuel pipe union. Wash these in petrol to remove any "foreign bodies" which have entered via the fuel tank.

Cleanliness of the engine is important—especially of the area around the clutch. A few drops of oil should be applied

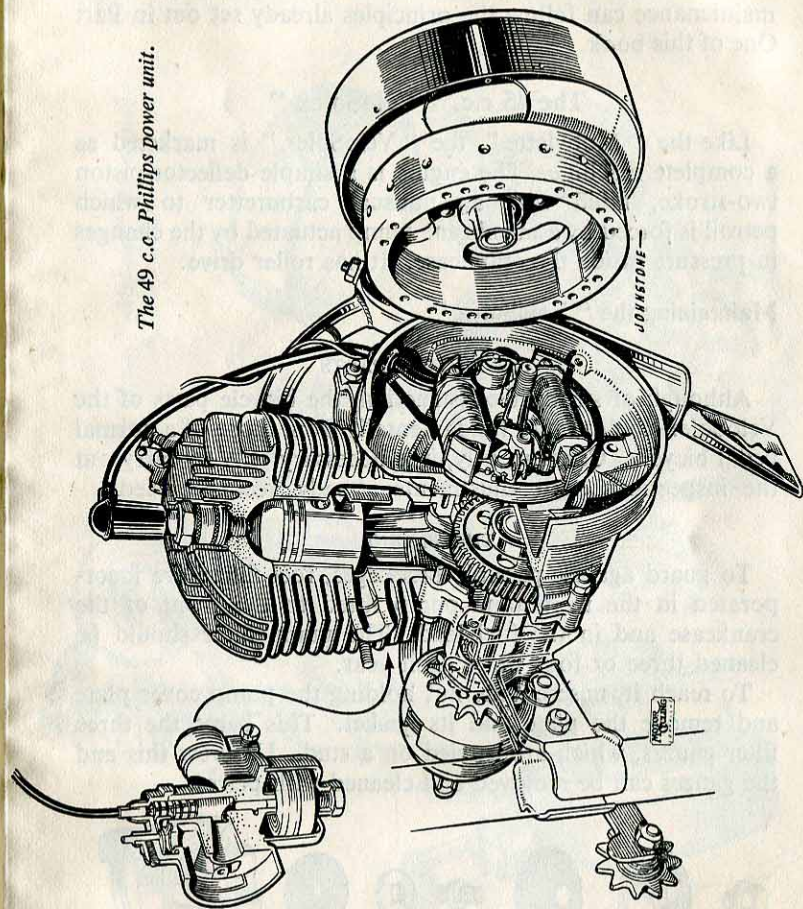

The 49 c.c. Phillips power unit.

between the engine casing and the drive sprocket, with the model tilted a little to the right. Then wheel it backwards and forwards once or twice with the clutch disengaged. Other maintenance can follow the principles already set out in Part One of this book.

### The 45 c.c. "VeloSolex"

Like the "Mobylette", the "VeloSolex" is marketed as a complete machine. The engine is a simple deflector-piston two-stroke, fitted with an unusual carburetter to which petrol is forced by a membrane pump actuated by the changes in pressure inside the crankcase. It has roller drive.

### Maintaining the "VeloSolex"

#### THE BICYCLE PARTS

Although of stronger construction, the bicycle parts of the VeloSolex do not differ fundamentally from those of a normal pedal bicycle. Consequently, it is necessary only to carry out the inspections and adjustments already recommended.

#### THE ENGINE

To guard against possible blockages, fuel filters are incorporated in the membrane pump fitted to the front of the crankcase and in the fuel lead. The pump filter should be cleaned three or four times each year.

To reach it, unscrew the nut holding the pump cover plate and remove the plate and its gasket. This bares the three filter gauzes, which are carried on a stud. Unscrew this and the gauzes can be removed and cleaned with petrol.

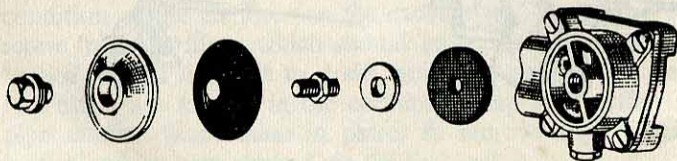

*This simple membrane pump, operated by variations in crankcase pressure, supplies fuel to the carburetter on the "VeloSolex". It contains a filter.*

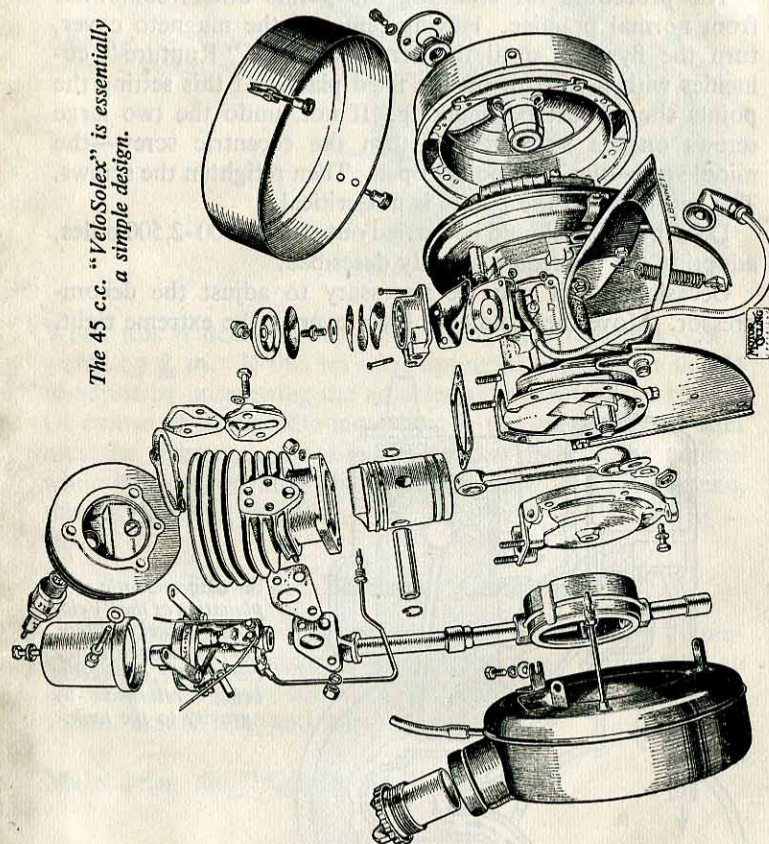

*The 45 c.c. "VeloSolex" is essentially a simple design.*

When delivered, the carburetter is fitted with a "running-in" air jet. After 200 miles have been covered, this must be exchanged for a jet one size larger, obtainable from your dealer.

The procedure for checking the points differs somewhat from normal practice. Having removed the magneto cover, turn the flywheel until the arrow marked "Rupture" coincides with the arrow on the fixed plate. At this setting the points should just be breaking. If not, undo the two large screws on the support and turn the eccentric screw—the middle one—until the points open. Then retighten the screws. The gap between the points is not critical.

Decarbonising should be carried out every 1,500–2,500 miles, adopting the procedure already described.

Occasionally, it may be necessary to adjust the decompressor. Move the handlebar lever over to the extreme right.

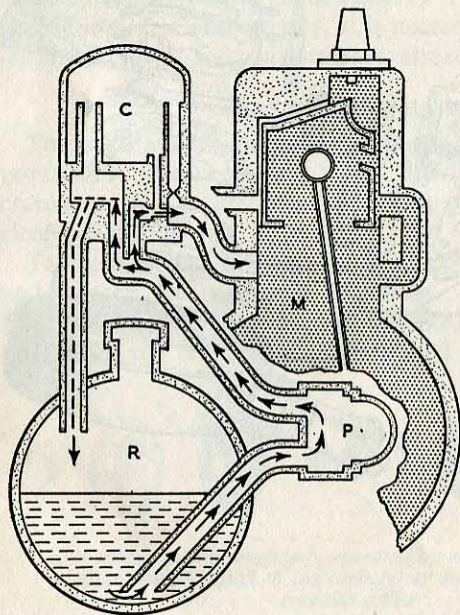

*A diagrammatic explanation of the "Velo-Solex" fuel system. Fuel is pumped to the carburetter, any excess being returned by gravity to the tank.*

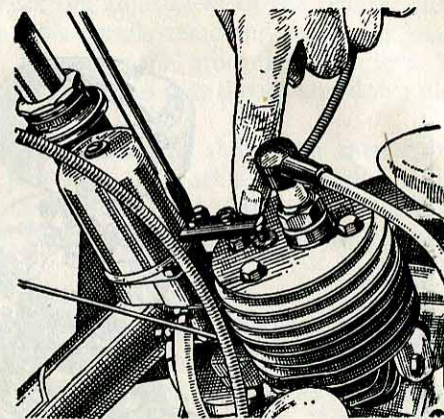

*Adjusting the "Velo-Solex" decompressor.*

When this is done, the spindle should have travelled downwards by  $\frac{3}{32}$  in. If this travel is appreciably less, you should re-adjust by unscrewing the adjuster at the rear of the rocker. Of course, if the spindle movement is too great, this adjuster must be tightened. To keep the rocker free of the control while you are working on it, press lightly on the front end, thereby levelling it.

### The 48 c.c. Zündapp "Combinette"

A high-quality German light autocycle, the Zündapp "Combinette" is the product of one of the most eminent of all German motorcycle concerns, and embodies features which should ensure long and reliable service.

### Maintaining the "Combinette"

#### THE BICYCLE PARTS

A set maintenance routine is advised by the machine's manufacturer. Every 600 miles, the clutch adjustment should be checked. This simply entails ascertaining that the clutch is neither dragging nor slipping, and that the "play" in the



The 48 c.c. Zündapp "Combinette" power unit.

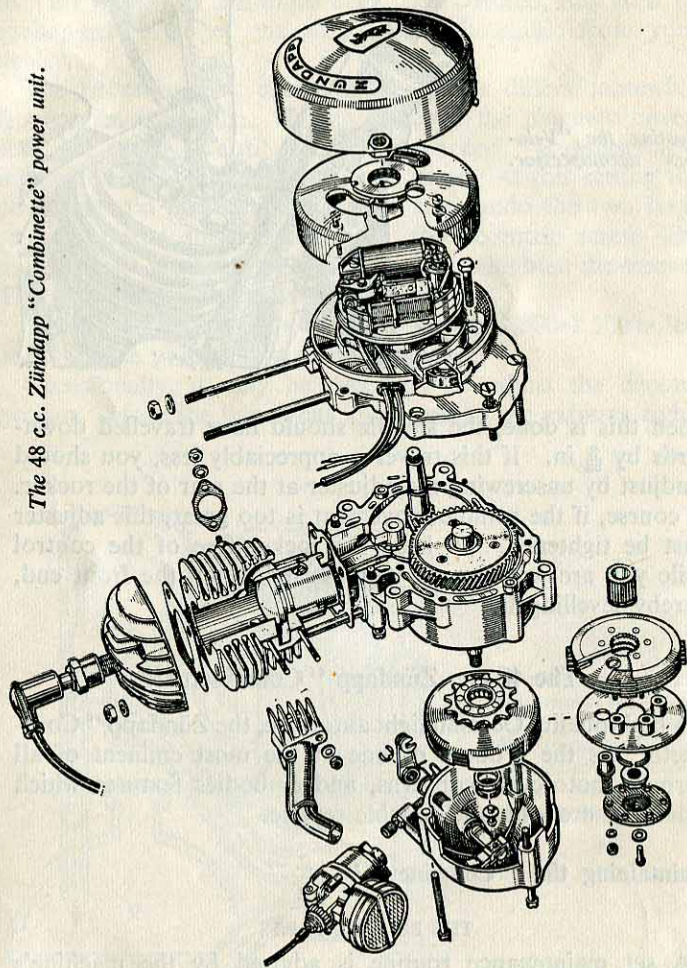

operating cable is just quarter of an inch—no more, no less. At the same time, check the adjustment of the brakes; clean and grease the chain (this entails removing the chain guard and the chain itself, following the procedure described for the N.S.U.); and refit the chain so that the up and down play is roughly 7/8-in.

Lubrication of the control cables should be carried out periodically. It is a good idea to fit cable lubricators. Alternatively, disconnect the cables, hold them up, and let oil trickle through them, following this up by greasing the exposed sections.

#### THE ENGINE PARTS

After 1,200 miles clean the carburetter. To reach this, shut off the fuel and remove the right-hand chain guard. Then release the spring clip on the air filter, remove the cone-shaped coupling, and detach the air cleaner complete. Dismantle the carburetter, clean both it and the air filter with petrol, and carefully re-assemble it—taking especial care to ensure that the float chamber fork moves easily. Take the opportunity, too, of checking over the various gaskets and see that all are in good shape.

At this mileage, one should measure the spark plug gap (.025-in.), the contact-breaker points gap (.012-.016 in.) and the ignition timing. This last-named operation is carried out by first removing the magneto cover plate and turning the flywheel until the ignition timing mark is between three-quarters and one and a quarter inches from the corresponding mark on the crankcase. In this position, which just allows access to the points, insert a thin metal strip (.0015-in.) between the points. Turn the flywheel further. As the two marks coincide, the points should begin to open, releasing the metal strip. Too early release, or too late, indicates incorrect timing, which should be re-adjusted in the manner described for the N.S.U.

When 1,800 miles have been covered, decarbonise the engine, paying particular attention to the exhaust port and pipe.

## TECHNICAL APPENDIX

Engine	Bore mm.	Stroke mm.	Capacity c.c.	Weight lb.	Recommended Plugs	Plug Gap in.
<b>B.S.A. "Winged Wheel"</b>	36	34	35	26½	Champion N.7.	.015-.018
<b>Bantamoto</b>	38	34	40	16	Champion N.8.	.020
<b>Berini</b>	36	32	32	15½	K.L.G. F.50 Bosch W. 175 T.1	.016-.018
<b>Cucciolo</b>	39	40	48	17½	Champion L.10 S	.018
<b>Cyclald</b>	35	32	31	15	K.L.G. F.50	.020
<b>Cyclemaster (Later Model)</b>	32 36	32 32	25.7 32	34 34	K.L.G. F.50 K.L.G. F.50	.018-.020 .018-.020
<b>Cymota</b>	38	40	45	25	Champion L.10	.018
<b>Itom</b>	39	40	48	22	K.L.G. F.70	.018-.020
<b>Mini-Motor</b>	38	44	49.9	24½	Lodge C. 14, K.L.G. F.50 Champion J.8	.018-.020
<b>"Mobylette"</b>	39	41.8	49	62	Champion L.10	.020-.025

## TECHNICAL APPENDIX

Recommended Lubricants	Normal Proportion Fuel/Oil	Carburetter			Manufacturers or Concessionaires
		Make	Main Jet	Needle Position*	
Any S.A.E. 50 oil	25 : 1	Amal	30	3	B.S.A. Cycles Ltd., Birmingham, 10.
Single Shell, Mobiloil Arctic, Castrolite, Essolube 20, Energol S.A.E. 20	20 : 1	Amal	27	3	No longer produced.
Any Brand S.A.E. 40 Mineral Oil	25 : 1	Amal	32	5 or 3	No longer imported.
Any Brand S.A.E. 40/50 (Summer), S.A.E. 30 (Winter)	Not Applicable	Weber	55	Not Applicable	Britax (London) Ltd., 115-129 Carlton Vale, London, N.W.6
Energol S.A.E. 20, Single Shell, Castrolite, Mobiloil Arctic, Essolube 20	30 : 1	Amal	25	3	British Salmson Aero Engines Ltd., 76 Victoria Street, London, S.W.1
Castrol XL, Energol 30, Essolube 30, Mobiloil A, Double Shell	25 : 1	Amal	30	3	Cyclemaster Ltd., 38a, St. George's Drive, Victoria, London, S.W.1.
Single Shell, Castrolite, Mobiloil Arctic, Essolube 20	16 : 1	Amal	25	3	No longer produced.
Any S.A.E. 30	16 : 1	Dell'Orto	52	Not Applicable	Adinar, 61 Clapham Road, London, S.W.9
Castrolite, Single Shell, Mobiloil Arctic, Essolube 20, Energol S.A.E. 20, Caltex 20	20 : 1	Trojan (Under Dell'Orto Licence)	43	Not Applicable	Mini-Motor (Gt. Britain) Ltd., Trojan Way, Croydon, Surrey
Castrolite, Single Shell, Mobiloil Arctic, Essolube 20, Energol S.A.E. 20	25 : 2	Gurtner	20	Not Applicable	Motor Imports Co., Ltd., 158 Stockwell Road, London, S.W.9

\* This indicates the groove in which the needle should be set, counting from the bottom.

## TECHNICAL APPENDIX

Engine	Bore mm.	Stroke mm.	Capacity c.c.	Weight lb.	Recommended Plugs	Plug Gap in.
Mocyc	40	40	49	20	Champion L.8	.022
Mosquito	35	40	38.5	15	K.L.G. F.70	.020
N.S.U.	40	39	49	72½	Bosch W.240 T.11 or equivalent	.018-.025
Phillips	40.5	38.25	49	69	Bosch W95TI Lodge B14 Champion L8 K.L.G. F20	.020-.024
Power Pak	39	41	49	22	Champion L.8	.020-.025
Teagle	40	40	49	—	Champion L.8	.022
V.A.P.	40	38	48	20	K.L.G. F.50	.018
VeloSolex	38	40	45	58	Champion L.8.	.020-.025
Vincent "Firefly"	38	42	48	24	K.L.G. F.20.	.018-.020
Zündapp	39	41.8	48	70	Bosch W.175 T.1 or equivalent.	.025

## TECHNICAL APPENDIX

Recommended Lubricants	Normal Proportion Fuel/Oil	Carburetter			Manufacturers or Concessionaires
		Make	Main Jet	Needle Position*	
Castrolite	16-20 : 1	Amal	27	3	Calrns Cycle & Accessories Mfg. Co. Ltd., Stoneswood, Todmorden, Lancs.
Mobiloil A, Castrol XL, Double Shell, Energol S.A.E. 30, Essolube 30	15 : 1	Dell'Orto	43	Not Applicable	Mosquito Motors, Ltd., Moorfields, Liverpool 2
Any S.A.E. 50 (engine, S.A.E. 30 (gear-box-summer) S.A.E. 20 (gear-box-winter))	25 : 1	Bing	—	—	N.S.U. Distributors Ltd., (Great Britain) Stevenage, Herts.
Any Brand SAE 30/40	24:1	—	—	—	Phillips Cycles Ltd., Birmingham 40
Castrol XL, Energol S.A.E. 30, Essolube 30, Double Shell, Mobiloil A	16 : 1	Amal	45	3	Sinclair Goddard & Co., Ltd. 162 Queensway, Bayswater, London, W.2.
Castrolite S.A.E. 20 (Summer), Castrol S.A.E. 10 (Winter), Castrol XL (hot climate)	—	Amal or B.E.C.	25 50	Middle —	W. T. Teagle (Machinery) Ltd. Truro, Cornwall.
Castrolite, Mobiloil Arctic, Single Shell, Energol 20, Essolube 20	16 : 1	Zenith or A.B.G.	45 (5) 7	2 Not Applicable	No longer imported.
Energol 10	16 : 1	Solex	22 c.c. (2.75 cc. air jet)	Not Applicable	Solex Cycles Ltd., SolexWorks, 223-231 Marylebone Road, London, N.W.1
Castrol XL, Mobiloil A, Shell X-100 (30), Energol S.A.E. 30, Essolube 30	24 : 1	Amal	30	Middle	Vincent Engineers Ltd., Stevenage, Herts.
Mobiloil Zwotamix (on Continent) or similar two-stroke oil	25 : 1	Bing 52	—	—	U.S. Concessionaires Ltd., Ascot, Berks.

\* This indicates the groove in which the needle should be set, counting from the bottom.

## INDEX

- "Bantamoto"**, 9, 85-7  
air filter, 87; bore, 118; capacity, 118; carburetter, 87, 119; chain adjustment, 87; description, 85; fuel/oil mixture, 119; gearcase oil level, 85; lubricants, 119; main jet, 119; maintaining, 87; manufacturers, 119; needle position, 119; sparking plugs, 118; sparking plug gap, 86, 118; stroke, 118; weight, 118.
- B.E.C. carburetter, 76, 78
- "Berini"**, 4, 5, 6, 118  
air filter, 57; bore, 118; capacity, 118; carburetter, 57, 119; description, 57; float chamber needle, 58; fuel/oil mixture, 119; lubricants, 119; main jet, 119; maintaining, 57; needle position, 119; sparking plugs, 58, 118; sparking plug gap, 118; stroke, 118; weight, 118
- Bottom Dead Centre (B.D.C.), 14
- Brakes  
adjustment of, 33; blocks, 34; caliper type, 34; coaster-hub type, 34; hub type, 33; rim type, 34; rod controlled, 34
- Carbon brush, 49
- Carburetter, 12, 18-20  
Amal, 45; blocked jet, 50; cleaning, 45; Dell'Orto, 65; float chamber, 19; jet, 18; needle, 19; pilot jet, 20; principle of, 18; slide, 19; slide removal, 40
- Caustic soda, 41
- Circlip, 43
- Clutch, 28
- "Combinette"**, 9, 115-17  
bore, 120; capacity, 120; carburetter, 117; clutch adjustment, 115; concessionaires, 121; description, 115; lubricants, 121; main jet, 121; maintaining, 115; manufacturers, 121; needle position, 121; sparking plugs, 120; sparking plug gap, 117; stroke, 120; weight, 120
- Compression  
checking, 51; loss of, causes, 51
- Condenser, 23
- Contact-breaker, 22, 23  
adjustment, 44; cleaning, 44; gap checking, 44, 49
- Control cables, lubricator, 46
- Crank, 11
- Crankcase, 11, 51, 52
- "Cucciolo"**, 8, 88-91  
bore, 118; capacity, 118; carburetter, 119; clutch adjustment, 90; concessionaires, 119; contact-breaker gap, 88; description, 88; filters, 91; lubricants, 119; main jet, 119; maintaining, 88; oil changing, 88; oil level, 88; sparking plugs, 118; sparking plug gap, 88, 118; stroke, 118; tappet adjustment, 88; weight, 118
- "Cyclaid"**, 8, 91-2  
belt adjustment, 92; bore, 118; capacity, 118; carburetter, 119; description, 91; fuel/oil mixture, 119; lubricants, 119; main jet, 119; maintaining, 92; manufacturers, 91, 119; needle position, 119; sparking plugs, 118; sparking plug gap, 92, 118; stroke, 118; weight, 118
- "Cyclemaster"**, 8, 92, 94-8  
bearing adjustment, 98; bore, 118; capacity, 118; carburetter, 119; chain adjustment, 94, 95; clutch adjustment, 94; description, 92; disengaging, 29; dismantling, 96; fuel/oil mixture, 119; lubricants, 119; main jet, 119; maintaining, 94; manufacturers, 119; needle position, 119; piston ring removal, 97; sparking

## THE Complete ANSWER TO MOTORISED CYCLING

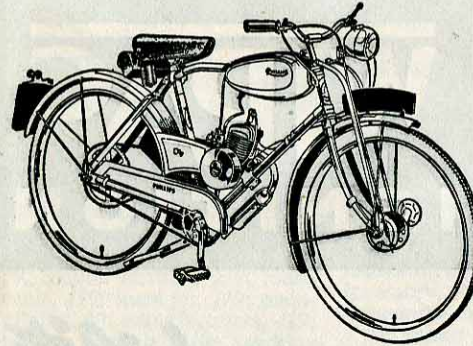

PRICE  
**£55. 12. 10**  
INC. P.T.

Complete with  
Stand & Miller  
or Lucas Lamps

Easy to start, simple to ride and control, and amazingly economical to run, the Phillips Motorised Bicycle requires only the minimum of maintenance and will give you years of trouble-free and pleasurable service.

# PHILLIPS

## MOTORISED BICYCLE

PHILLIPS CYCLES LTD BIRMINGHAM · ENGLAND

**BANTAMOTO**  
**MINI-MOTOR**  
**BERINI**  
**CYCLEMASTER**  
**POWER**  
**PAK**  
**TEAGLE**  
**CYCLAID**  
**MOCYC**  
**B.S.A.**  
**WINGED**  
**WHEEL**  
**MOTAMITE**

*all fit*

**WIPAC**  
**IGNITION**

*for reliability*

**T**HE majority of power-assisted cycles are fitted with **WIPAC IGNITION** as original equipment. You should therefore make certain that you replace only with genuine **WIPAC SPARES**

**THE WIPAC GROUP**  
**BLETCHLEY · ENGLAND**



**INDEX**

"Cyclenator"—*contd.*  
 plugs, 118; sparking plug gap, 118; stroke, 118; tyre pressures, 94; weight, 118; wheel removal, 95

"Cyclenator", 9 (see "Cyclenator" for details)

Cyclenator  
 commercial use, 2; driving technique, 30; fuel consumption, 1; initial cost, 3; running costs, 3; speed, 1; starting, 30; stopping, 30; touring with a, 2

Cylinder head, 11  
 removal, 41

"Cymota", 5, 58-61  
 air filter, 60; bore, 118; capacity, 118; carburetter, 119; contact-breaker, 60; cowling removal, 59; decarbonising, 61; description, 59; fuel/oil mixture, 119; lubricants, 119; main jet, 119; maintaining, 60; manufacturers, 119; needle position, 119; sparking plugs, 118; sparking plug gap, 118; stroke, 118; weight, 118

Decarbonising, 40-4

Decompressor, 17

Driving licence, 26

*Driving Test Fully Explained, The*, 26

"Ducati", 8, 88-91  
 bore, 118; capacity, 118; carburetter, 119; chain adjustment, 91; clutch, 91; description, 88; lubricants, 119; main jet, 119; maintaining, 88; manufacturers, 119; sparking plug gap, 118; tappet adjustment, 88, 90

Electrical equipment, 22-3

Emery cloth, 43

Exhaust system, 39

Feeler gauge, 49  
 substitute for, 49

Filler cap, vent hole, 49

Fins, 11

"Firefly", 7, 78-81  
 bore, 120; capacity, 120; carburetter, 121; description, 78; fuel/oil mixture, 121; lubricants, 121; main jet, 121; maintaining, 80; manufacturers, 121; sparking plug gap, 80

Flywheel, 11

Four-stroke engine, 11-14  
 operation of, 12, 14; principle, 13

Fuel leads, blockage of, 49

Fuel tap, blockage of, 49

Gaskets, 42

H.T. lead, faults in, 50  
 repairing, 50

Handlebar layout, 28

*Highway Code, The*, 27

Hubs, adjustment of, 35-6  
 component parts, 35

Insulating tape, 50

Insurance, 24-7  
 comprehensive, 25; cover note, 25; Motor Insurers' Bureau, 25; obtaining, 25; third party, 24-5; transfer of, 27

Itom, 5, 60-2  
 bore, 118; capacity, 118; carburetter, 119; concessionaires, 119; description, 60; exhaust system, 60; fuel/oil mixture, 119; lubricants, 119; magneto points, 62; main jet, 119; maintaining, 62; sparking plugs, 118; sparking plug, 118; stroke, 118; weight, 118

Joints, loose, 50  
 temporary repair, 50

L-plates, 26

Licence holder, 26

Lubrication, 20-1

Magneto, flywheel, 23  
 condenser, 23; construction, 23; contact-breaker, 23; Wico-Pacy, 22

"Mini-Motor", 7, 62-6  
 aligning, 64; bore, 118; capacity, 118; carburetter, 119; decompressor, 64, 65; description, 62;

INDEX

- "Mini-Motor"—*contd.*  
 fuel/oil mixture, 119; gaskets, 62; handlebar lever, 62; lubricants, 119; main jet, 119; maintaining, 62; manufacturers, 118; roller grooves, 64; roller pressure, 66; silencer, 66; sparking plugs, 118; sparking plug gap, 118; stroke, 118; weight, 118
- "Mobylette", 9, 101-3  
 bore, 118; capacity, 118; carburetter, 121; concessionaires, 118; contact-breaker adjustment, 103; decompressor adjustment, 101; description, 101; lubrication, 101, 121; main jet, 121; maintaining, 101, 103; sparking plugs, 118; sparking plug gap, 118; stroke, 118; transmission adjustment, 103; tyre pressures, 101; weight, 118
- "Mocyc", 5, 66-8  
 bore, 118; capacity, 118; carburetter, 119; contact-breaker, 68; description, 66; fuel/oil mixture, 121; ignition timing, 68; main jet, 68; maintaining, 68; manufacturers, 120; needle position, 121; sparking plugs, 68, 120; sparking plug gap, 68, 120; stroke, 120; tail pipe, 68; weight, 120
- "Mosquito", 7, 69-70  
 bore, 120; capacity, 120; carburetter, 121; contact-breaker points, 69; cylinder removal, 69; deflector plugs, 69; description, 69; fuel/oil mixture, 121; gear primary drive, 69; gear teeth, 69; ignition timing, 69; lubricants, 121; main jets, 121; maintaining, 69; manufacturers, 121; needle position, 121; sparking plugs, 70, 120; sparking plug gap, 70, 120; stroke, 120; weight, 120
- Number plates, 27
- Petrol, 21
- Phillips, 9, 110-12  
 bore, 120; capacity, 120; carburetter, 110, 121; concessionaires, 121; description, 110; fuel/oil mixture, 121; lubricants, 121; maintaining, 110; manufacturers, 121; sparking plug gap, 120; stroke, 120; weight, 120
- Piston, 11
- Piston ring, 11, 43  
 grooves, 43; pegs, 43; removal, 43; replacement, 43
- Ports, 11
- Power, loss of, 52
- "Power-Pak", 7, 70, 72-5  
 big-end circlip, 72; bore, 120; capacity, 120; carburetter, 121; decompressor valve, 72; decompressor adjustment, 72; description, 70; disengaging, 29; fuel-oil mixture, 121; greasing crankcase, 75; lubricants, 121; main jet, 121; maintaining, 74; manufacturers, 121; needle position, 121; roller adjustment, 72; sparking plug, 76, 120; sparking plug gap, 76, 120; stroke, 120; weight, 120
- "Quickly", 9, 103  
 bore, 120; capacity, 120; carburetter, 121; description, 103; fuel/oil mixture, 121; lubricants, 121; main jet, 121; maintaining, 103; manufacturers, 121; sparking plug gap, 106, 120
- Road Fund Tax, 26  
 renewal, 27
- Rotary valve,  
 on "Cyclemaster", 9
- Saddle, 39
- Sparking plug, 14, 23, 49-51  
 adjusting, 49; checking, 49; cleaning, 49; electrode, 49; grade, 52; surface deposit, 49; "whiskering", 48
- Spokes, 35
- Steering head, 37, 38
- Teagle, 75, 78  
 bore, 120; capacity, 120; carburetter, 72, 76, 121; concessionaires, 121; description, 75;

IF YOU HAVE A CYCLEMASTER

(OR A CYCLEMATE)

You want this plug!

All small two-stroke engines are more liable than other engines to the plug trouble known as 'whiskering'. Whiskering means the formation of small, whisker-like deposits which grow between the electrodes of the plug until they bridge the spark gap completely and cause the spark to fail. The entirely new K.L.G. C-F.50 plug has been specially designed for Cyclemaster and Cyclemate engines, and offers a positive answer to the danger of whiskering. The design of the C-F.50 is—in the most literal sense—revolutionary. It defeats whiskering by means of a revolving earth-electrode. Engine vibration causes the earth electrode to rotate, slowly but continually, round the centre electrode. The three spark gaps themselves are thus in constant motion, which gives whisker deposits no chance to build up. **Price 5/-**

FOR RELIABLE, TROUBLE-FREE RIDING... THE

**K.L.G.**

**C-F.50 anti-whisker sparking plug**

one of **SMITHS** accessories for better performance

SMITHS MOTOR ACCESSORIES LTD., K.L.G. SALES DEPT., CRICKLEWOOD WORKS, LONDON, N.W.1  
 THE MOTOR ACCESSORY DIVISION OF S. SMITH & SONS (ENGLAND) LTD.

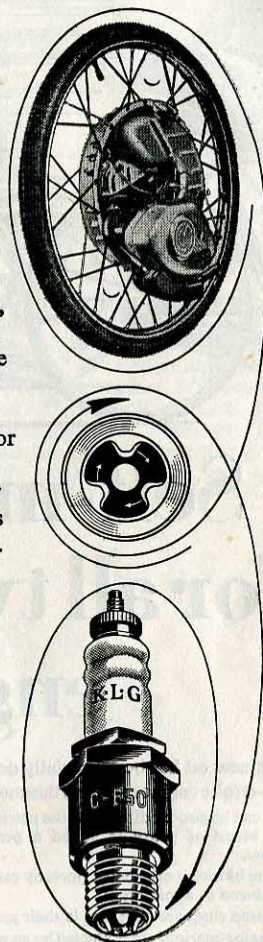

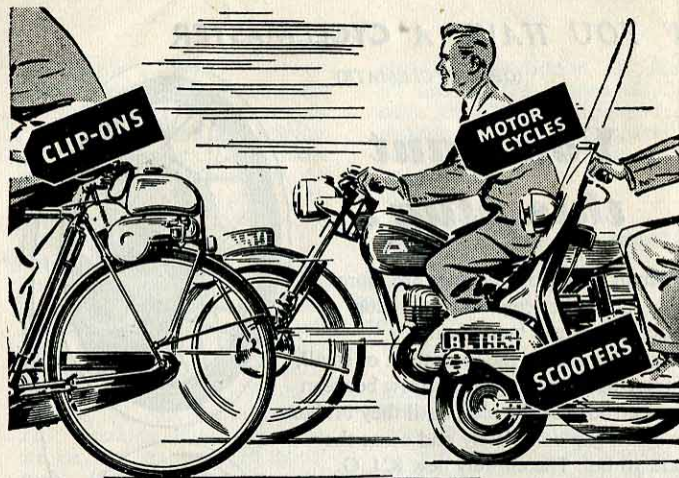

# Self-mixing oil for all two-stroke engines

This new oil has been specially developed for two-stroke engines and has these advantages:-

- 1 It can be poured direct into the petrol tank. When any brand of petrol is added a perfect mixture results.
- 2 The blocking of exhaust ports by carbon deposits is reduced to a minimum.
- 3 Piston rings are kept free in their grooves.
- 4 Engine bearings are protected by an anti-corrosive additive (British Patent 588864).
- 5 Castrol Two-Stroke Self-Mixing Oil is available at your garage from bulk or in a sealed quart tin at normal Castrol prices.

**NOTE:-** Make sure that the petrol tap is turned off before the oil is poured in. Per gallon of petrol use  $\frac{1}{2}$  pint of oil (or the proportion advised by the engine maker for this oil).



**TWO-STROKE  
SELF-MIXING OIL**

## INDEX

Teagle—*contd.*

fuel/oil mixture, 121; lubricants, 121; main jet, 121; maintaining, 75; manufacturers, 121; sparking plug gap, 76, 120; stroke, 120; weight, 120

Two-stroke engine, 14-17

operation of, 14-17; principle of, 14, 15

Tyres, inflation, 35

"V.A.P.", 9, 98-100

bore, 120; capacity, 120; carburetter, 121; clutch, adjustment 100; concessionaires, 121; description, 98; disengaging, 29; fuel/oil mixture, 121; lubricants, 121; main jet, 121; maintaining, 98; manufacturers, 121; sparking plugs, 120; sparking plug gap, 120; stroke, 120; weight, 120

Valves, 11

grinding-in, 41

"VeloSolex", 9, 112-15

bore, 120; capacity, 120; carburetter, 121; carburetter jet, 100, 118, 121; contact-breaker adjustment, 118; decompressor adjustment, 118; description, 112; fuel/oil mixture, 121; fuel pump filters, 114; lubricants, 121; main jet, 121; maintaining, 112; manufacturers, 121; sparking plugs, 120; sparking plug gap 120; stroke, 120; weight, 120

Wheels, 35

"Whiskering," 48

"Winged Wheel", 9, 82-5

bore, 118; capacity, 118; carburetter, 119; clutch adjustment, 84; concessionaires, 119; description, 82; fuel/oil mixture, 119; lubricants, 119; main jet, 119; maintaining, 82; manufacturers, 119; sparking plug gap, 82; stroke, 118; weight, 118

# Webb

Reg'd.  
TRADEMARK

## SPRING FORK

British and  
Foreign Patents  
Applied for

For PERFECT  
COMFORT AND  
CONTROL . . .

ROAD SHOCKS  
& VIBRATION  
ABSORBED

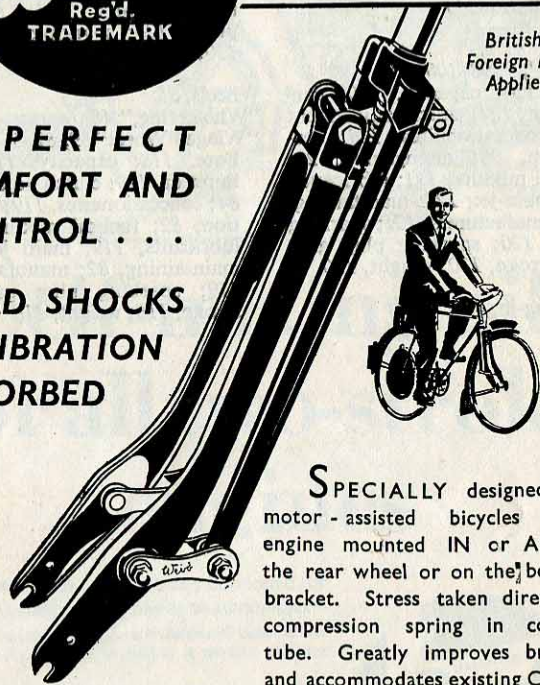

Additional weight  
only  $2\frac{3}{4}$  lbs. approx.

SPECIALLY designed for motor-assisted bicycles with engine mounted IN or ABOVE the rear wheel or on the bottom bracket. Stress taken direct on compression spring in column tube. Greatly improves braking and accommodates existing Caliper or Hub Brakes. Special Cable-operated Stirrup Brake available for cycles fitted with Roller Lever Brakes.

Order from your Agent or write to us for Leaflet

H. C. WEBB & CO. LTD., YAME ROAD, WITTON, BIRMINGHAM, 6.

more POWER, more RELIABILITY

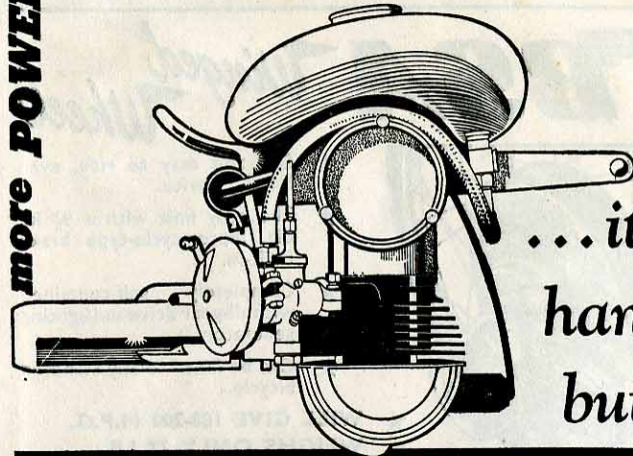

... it's  
hand  
built

# POWER PAK

It's the tops! It's the bicycle motor with more p-o-w-e-r and performance than any other make. It's tough. It abounds in spirit and energy. It's brisk, active and vigorous.

Readers of the Cyclemotor Manual will quickly appreciate the accessibility of this unit. You can get at everything easily for service and adjustment.

The rear wheel position allows the motor to spread out logically. Not building in a confined space we use the simplest arrangement for power transmission — piston — conrod — crankshaft. We also have room to use big sturdy bearings — but that's another story. Further details gladly sent from :

THE BICYCLE MOTOR  
THAT TOOK  
PETER LEE-WARNER  
ROUND THE WORLD  
without using any spares.

POWER PAK · 162 QUEENSWAY · LONDON W.2



**FOR RELIABLE, SAFE POWER-CYCLING**

# **BSA** *Winged Wheel*

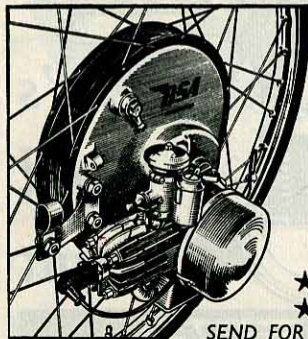

- ★ Safe and easy to ride, even for the novice.
- ★ The only unit with a 9½ in. dia. motor-cycle-type brake built-in.
- ★ Completely self-contained with all-gear drive and lighting generator.
- ★ Can be fitted to any standard bicycle.

★ **WILL GIVE 180-200 M.P.G.**

★ **WEIGHS ONLY 27 LB.**

SEND FOR FULL DETAILS

B.S.A. CYCLES LTD., 366, WAVERLEY WORKS, BIRMINGHAM, 10

## **Insist on Colloidal Cyclemotor Filtrate**

*says Fluid Phil*

Exhaustive tests have proved that high-grade oil blended with Acheson Colloidal Graphite inestimably improves the lubrication of two-stroke Motor Cycles. It is exclusively recommended for Minimotors and is approved by others. (The maximum proportion to use is 1 part to 32 parts of petrol.)

Available through Halfords and Motor Cycle Dealers.

Write to Fluid Phil TODAY for full details.



Another famous **FILTRATE** Product

E EDWARD JOY & SONS, LTD., LEEDS. Est. 1807 "Between Trafalgar and Waterloo"

# LIGHTING SETS

FOR POWER  
ASSISTED CYCLES

Head and Tail Lamp Set No. 431 for use with engines which incorporate a lighting coil in the flywheel generator. Supplied complete with bulbs and twin cables with connecting nipples and terminals.

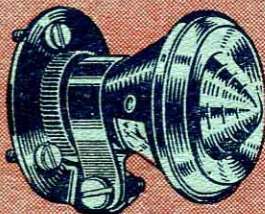
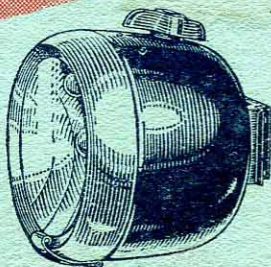

VT31 Tail Lamp conforms to the new regulations, having a 1 1/2" diameter lens moulded in red plastic specially designed to give a wide spread of light. A clear window gives ample number plate illumination.

Set No. 331 The Headlamp, has provision for a standby battery, and is supplied with twin cables connecting nipples, terminals and matched bulbs. The VT31 Tail lamp conforms to the new lighting regulations. This set is for use with engine units which incorporate a lighting coil in the flywheel generator.

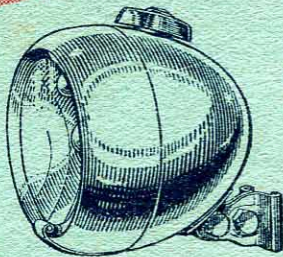

## LUCAS

*"King of the Road"*  
LIGHTING SETS

JOSEPH LUCAS (CYCLE ACCESSORIES) LTD., BIRMINGHAM, 6

# IceniCAM Information Service



[www.icenicam.org.uk](http://www.icenicam.org.uk)