



FROM FEB. 1st. 1953 UNTIL FURTHER
NOTICE ALL PRICES IN THIS LIST
ARE INCREASED BY 25%

“PETITE” CAR

MAINTENANCE INSTRUCTIONS

AND

SPARE PARTS LIST

for the

Villiers

MARK 27B

Two-Stroke Engine

From December 19th. 1955, until further notice,
all prices in this list are increased by 20%.

The VILLIERS ENGINEERING Co. Ltd.
WOLVERHAMPTON **ENGLAND**

TELEGRAMS:
“VILLIERS”
WOLVERHAMPTON.

*Marston
Road*

TELEPHONE:
21666-7-8 WOLVERHAMPTON
26065/6 SERVICE DEPT

AUG, 1954.

GENERAL DATA.

BORE	-	-	-	-	70 m.m.
STROKE	-	-	-	-	90 m.m.
CAPACITY	-	-	-	-	346 c.c.
CARBURETTER	-	-	-	-	VILLIERS TYPE S24.
„	NEEDLE	-	-	-	No. 3½.
„	„	SETTING	-	-	1.95" OUT.
SPARKING PLUG	-	-	-	-	LODGE H.L.N. 18.
PLUG GAP	-	-	-	-	.015"/.025".
IGNITION TIMING	-	-	-	-	$\frac{3}{8}$ " B.T.D.C.
CONTACT POINT GAP	-	-	-	-	.015 Max.

LUBRICATION—

Petrol Mixture. For the First 500 miles 1 part Castrol XL (SAE.30) oil to 16 parts petrol and subsequently 1 part to 20 parts. Mix well before filling tank.

MAINTENANCE AND REPAIRS

1. DECARBONISING.

Decarbonising the Villiers Two-Stroke Engine is quite straightforward, because of the simplicity of this type of unit. The following points, however, are worth special attention.

When removing and replacing the cylinder, care should be taken not to twist it round the piston—it should be pulled off or pushed on straight so that the rings cannot catch in any of the ports and break.

After approximately 2,000 miles running, the cylinder head should be lifted for removal of carbon from inside, and also top of piston. Both cylinder head and piston are made in an aluminium alloy, and care must therefore be taken not to scratch the surfaces or to remove any metal.

After approximately 5,000 miles running the cylinder should be lifted, and the exhaust manifolds removed. Any carbon formation in the ports must be removed, but the shape or sizes of the ports in cylinder must not be altered.

Piston ring grooves must be kept free from carbon in order to leave the rings quite free. Piston rings should be bright round their surface which makes contact with the cylinder bore. Should wear cause the joint gap to exceed $1/32$ in. when in the cylinder, the piston ring should be replaced.

A gasket is fitted between cylinder and cylinder head, and to maintain a perfect gas tight joint, occasionally check tightness of cylinder head bolts. No jointing compound should be used on the joint faces.

It is of the utmost importance that silencers and exhaust pipes are kept quite clean internally, and that a heavy deposit of carbon is not allowed to accumulate. This will cause back pressure and loss of power.

It is important that air leaks should be avoided.

The connection between carburetter and induction pipe must be absolutely airtight, and after dismantling an engine, new washers should always be fitted at the induction pipe joint, and cylinder base joint, if the original ones have been disturbed.

2. SPARKING PLUG.

The type recommended is the Lodge HLN 18, 18 mm.

Clean and reset the points .018 in. gap after each 2,000 miles running.

Adjustment of the gap should be done by moving the points attached to the outer body of the plug. **Never bend the centre pin.** Keep the outside of the plug insulation free from water and dirt. When screwing the plug in the cylinder head, should any undue stiffness be experienced, do not use force but examine the thread for any particles of grit or carbon which may be present. These must be removed, otherwise the threads in the cylinder head may be damaged. It is a good plan to smear a little graphite grease on the plug threads before replacing.

3. PETROIL FILTER.

There is a fine mesh filter gauze on the bolt securing the petrol pipe banjo connection to the carburetter body. This filter should be periodically cleaned by dipping in petrol, and when replacing, make sure that the fibre washers make a petrol tight joint.

4. AIR FILTER.

This must be removed every 1,000 miles, or more frequently under very dusty conditions, and washed in petrol, then dip in **thin oil**, and allow surplus to drain off before refitting.

5. CONTACT BREAKER.

The contact breaker points should be checked occasionally to see that they are clean, that the gap when fully opened is between .012 in. and .016 in., and that they open and close properly. To obtain access to points, first remove cowl front (Illustration 4, page 10), then the starter pulley (Illustration 2), after which the condenser box cover (Illustration 51) can be taken off.

The magneto screwdriver supplied has a feeler gauge attached, which should be used to check the point gap.

6. MAGNETO TIMING.

The magneto is timed so that the contact points commence to open when the piston is $\frac{3}{16}$ " BEFORE top dead centre. When the timing is originally done in the Works an arrow is stamped on the face of flywheel boss in line with the timing slot cut on one side of the end of crankshaft. (See Fig. 1.) Subsequent timing is carried out by placing the marks in line, but it is advisable to check the actual contact point opening in relation to position of piston before finally tightening the flywheel centre nut.

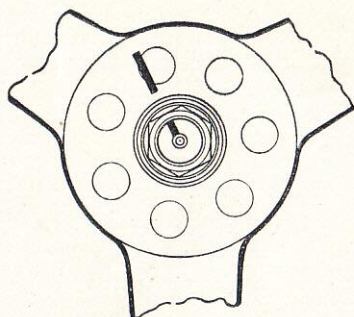

Diagram illustrating Timing Marks.

Fig. 1.

Contact Breaker Assembly.

This is of the latest type requiring a screwdriver only to adjust the contact points. To adjust the contact points proceed as follows:—

Turn flywheel clockwise until rocker pad is on top of cam profile of flywheel boss. Release the screw "A" (see Fig. 2). Position bracket "B" by turning adjuster cam "C" until .015" feeler gauge can be inserted between the contact points. Tighten screw "A" and withdraw feeler gauge. It is not necessary to disturb nut "D" when adjusting point gap. A felt pad is used to keep the cam in a slightly oily condition, and is impregnated when new with grease. This can, if

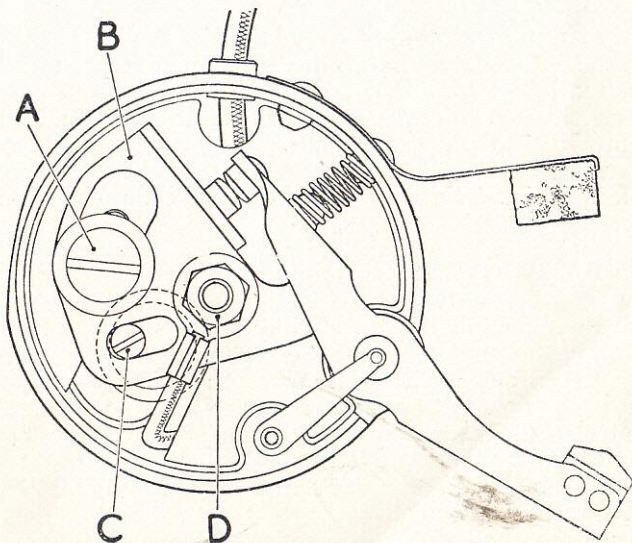

Fig. 2.

visibly dry, be oiled with a small amount of the heaviest oil available. It is better, however, to soak the pad in a molten high temperature grease if it is convenient to detach the box itself for this operation. If too much oil is put on the felt pad it may creep along the Rocker Arm, get on the contact points, and so cause ignition trouble.

7. FLYWHEEL REMOVAL.

The cam operating the contact breaker is rivetted to the flywheel which is driven by a taper on the crankshaft, and if alteration to magneto timing is necessary, the flywheel must be released, by unscrewing the centre nut with the box spanner provided in the tool kit. This nut has a right-hand thread and is imprisoned in the flywheel and it should be unscrewed until the flywheel is just free to revolve on the crankshaft. With the piston $\frac{3}{16}$ " before top dead centre, the flywheel should then be moved round clockwise until the points commence to open, then lightly tighten up the nut and re-check timing. After checking, tighten up the nut by hitting with a hammer on the end of the tommy bar.

The taper of shaft and cam must be clean and dry; if any oil is present on the surfaces it will be impossible to secure an effective drive.

8. COOLING SYSTEM.

It is most important that the complete cowling and fan should be in position when the engine is running.

9. CARBURETTER.

The Carburetter fitted to the Mark 27B engine is the Type S.24. In this Carburetter the position of taper needle in relation to the throttle is adjustable by means of the special screw situated in centre at top of throttle. This adjustment is provided to suit individual engines, and it should not be necessary to alter the makers setting except after considerable mileage. The standard setting from throttle to end of taper needle is 1.95 inches.

OPERATION OF CARBURETTER.

The handlebar twistgrip (or lever) control operates the throttle slide and thereby regulates the amount of mixture entering the engine, whilst the carburetter itself automatically meters and atomises the correct amount of fuel to give the necessary mixture strength. To achieve this automatic control of the mixture strength, two separate fuel systems are fitted, namely the main-jet and pilot-jet systems. At idling speeds the carburetter draws fuel from the pilot-jet and, as the throttle is gradually opened, the fuel is then drawn in turn from the pilot "progression" hole and the main-jet

system. The operation of the two systems is given below :—

1(a) Pilot-Jet System.

At idling speeds, when the throttle is nearly closed, the pilot outlet hole (A) Fig. 3 is subject to the very high engine suction, and petrol is, therefore, drawn from the float chamber through the pilot tube (B), and the pilot outlet hole. The calibrated pilot-jet is contained in the top of the pilot tube. At the same time, a filtered supply of air is drawn from the mouth of the carburetter through passage C, through the variable air-jet D, and is then pre-mixed with the fuel in the small chamber E. The pilot adjuster screw F varies the size of the pilot air jet, and therefore, the pilot mixture strength—to richen mixture, turn screw clockwise.

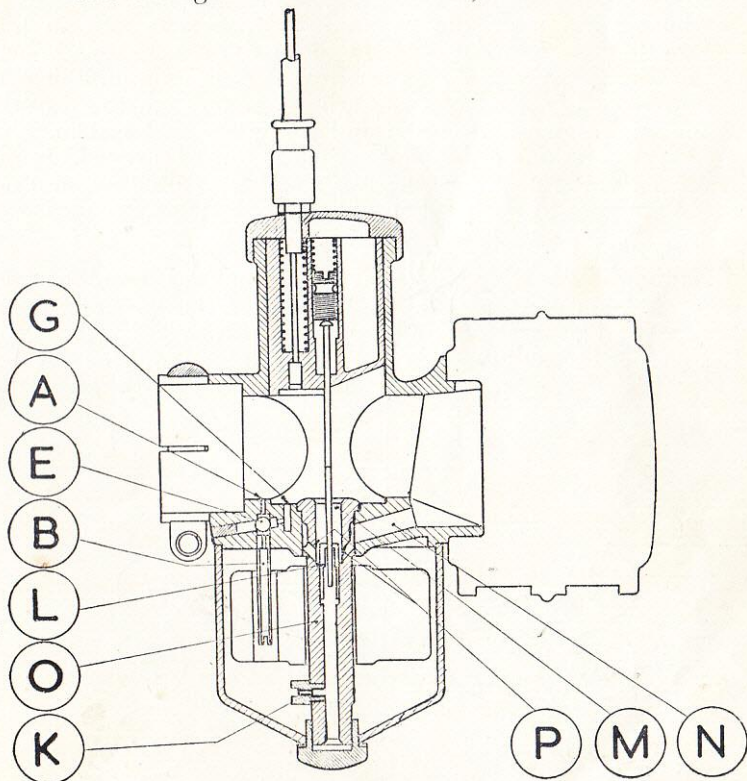

Fig. 3.

When the throttle slide is opened a small amount beyond that required for idling, the suction on the pilot outlet hole is reduced, but at the same time, the suction on the pilot "progression" hole (G) increases. A further supply of petrol

is, therefore, drawn through the "progression" hole, and prevents the weak spot which would otherwise occur due to the fall off in supply from the pilot hole before the main jet comes into full operation.

It follows from the preceding remarks that whenever the throttle is shut off whilst the engine speed is high (such as on long downhill sections), the pilot system is subject to the full engine suction, and petrol will flow into the engine from the pilot outlet hole. As the engine is not firing under these conditions, this fuel supply will tend to build up in the crankcase and cylinder and cause severe "four-stroking" or "eight-stroking" when the throttle is opened again. To overcome this fault in the present range of Villiers Carburetters, an automatic air bleed to the pilot has been incorporated, which relies upon the matching of two slots, one in the throttle slide and the other in the carburetter body. When the throttle slide is shut, these two slots line up and air can flow from the front of the Carburetter through the throttle slide and down passages H and J into the pilot system. The high depression on the pilot system is then destroyed. In all other throttle positions, the two slots do not line up, and no air can pass to the pilot system through these passages.

1(b) Main Jet System.

As the throttle slide is opened further beyond the idling and progression positions, the engine suction has its effect upon the main-jet system, and petrol is drawn from the float chamber through the calibrated main jet (K) and the needle-jet (L) and into the small pre-mixing chamber (M). There the

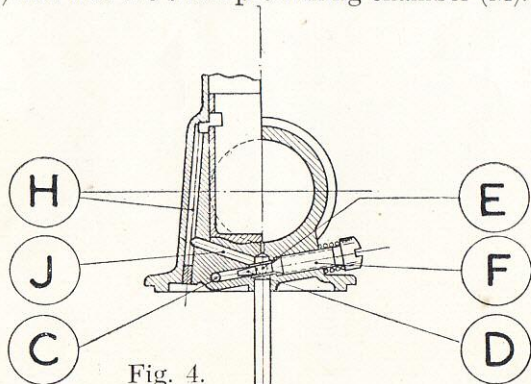

Fig. 4.

petrol is atomised by the filtered secondary air which is drawn from the mouth of the carburetter along passage (N), and which enters the centrepiece (O) through four small holes (P). The rich petrol-air mixture then flows from the pre-mixing chamber into the main mixing chamber, where it meets the main air stream. The effective size of the needle-jet (L) depends upon the throttle slide position (as the taper

needle is fixed to the slide), and the sizes of the needle-jet and the needle are chosen to give correct carburation over the range.

TUNING CARBURETTER.

Before any attempt is made to tune the Carburetter it is essential that the engine is in a good mechanical condition. This means that there should be no air leaks at any of the joints, there should be a good spark at the plug points and also that there is no restriction in the fuel supply. It is also important, of course, that the carburetter is clean internally, and that the air filter is not obstructed.

There are four adjustments for tuning the carburetter, but each of these has its full effect at a particular part of the throttle range, and should, therefore, only be used for tuning that particular part of the range. There is also a definite sequence for the tuning, and this also must be adhered to in order that the results achieved with one adjustment are not upset by the next adjustment.

The sequence of tuning with the necessary adjustments is given below :—

(1) Main Jet. Throttle Range— $\frac{3}{4}$ to Full.

In order to obtain the correct main jet size, the engine must be tested at full throttle in top gear. If the engine lacks power, detonates badly or runs better with the strangler slightly closed, a larger main jet is required. Should the engine "four-stroke" or improve momentarily after the petrol has been switched off, a smaller jet is required. After de-clutching and stopping the engine quickly the sparking plug should have a shiny black appearance if the correct main-jet is fitted. As an additional guide the engine should tend to "four-stroke" at full throttle in bottom gear on level ground (or high engine speeds in neutral), but not in any higher gears.

(2) Pilot Jet. Throttle Range—Closed to $\frac{1}{8}$ open.

The pilot jet must be set when the machine is stationary with the engine running at the required idling speed. To richen mixture, screw in the pilot adjuster screw, and to weaken unscrew pilot adjuster. The mixture strength must be set as weak as possible consistent with a steady reliable idling speed and good engine acceleration from this throttle position. If the mixture strength is set too rich, trouble will be experienced with the fuel build-up in the crankcase when the throttle is shut with the engine still running fast. Should this latter fault be present after adjusting the pilot, unscrew pilot a further half a turn. Any weakness on acceleration can be cured by throttle cut away as given on next page :—

(3) Throttle Cut-Away. Throttle Range— $\frac{1}{8}$ to $\frac{1}{4}$ Open.

The throttle slide is made with a cut-away on the carburetter inlet side which influences the depression on the main-jet system. The throttles are marked with a number which represents, in sixteenths of an inch, the amount of cut-away. A throttle with more cut-away will give weaker mixtures (over the particular throttle range) and vice-versa.

(4) Needle Adjustment :— Throttle Range— $\frac{1}{4}$ to $\frac{3}{4}$ Open.

The needle is adjusted by the grub screw in the top of the throttle—screw down to weaken mixture, and vice-versa. The needle controls the mixture strength over most of the "cruising range" and must be correct for good fuel consumption and acceleration. After carrying out the above adjustments, it is wise to go back and re-check the pilot adjustment to see that this has not been affected by other adjustments.

TO CHANGE THE TAPER NEEDLE.

Remove throttle from body after unscrewing the top ring, and in the centre at top of throttle will be found a small slotted screw. This is the adjuster referred to in the previous paragraph, and when this is removed by unscrewing the needle with spring can be pushed up from underneath. When replacing the needle make sure that the needle collar is in position.

TO REMOVE THE CENTREPIECE.

It is necessary first to remove the throttle, then the bottom nut and fibre washer holding the float chamber in position. Before the float can be removed it is necessary to unscrew the main jet from the side of the centrepiece. After removal of float do not disturb the pilot jet tube fixed to underside of body. The centrepiece can now be pushed up from underneath and out through the throttle bore.

Having removed the centrepiece, the forked lever on the underside of the body can be swung on one side to allow the fuel needle to drop out. Do not alter the shape of the fuel needle lever as this component governs the height of the petrol in the float chamber. Should, however, the lever be damaged, it should be reset to give a distance of $\frac{1}{8}$ inch between the top of float and underside of body when the fuel needle is fully raised.

TO REASSEMBLE CARBURETTER.

Clean the various components and make sure that the tickler vent hole is clear. Insert the centrepiece making sure that the forked fuel needle lever and fuel needle are in position. Place float in position and replace main jet in side of centre-piece. Clean out the float cup and replace with large fibre

joint washer at top. Replace bottom nut and fibre washer, but do not use too much force, otherwise there is the danger of stripping the thread of centrepiece. Replace throttle in body at the same time guiding the taper needle into hole in top of centrepiece. Locate top disc in top of body and screw on top ring.

If the carburetter has been removed from the Engine, make sure when refitting that the body is pushed on to the manifold as far as possible. There are four narrow slots in the body to allow the securing clip to function, and if the manifold stub does not extend past the end of the slots, air will be sucked in causing hard starting and erratic running.

The carburetter has a banjo petrol pipe fitting inside of which is a fine mesh filter gauze which should be periodically cleaned by dipping in petrol. Be sure that when replacing the petrol pipe the fibre washers make a petrol tight joint, otherwise fuel will be wasted.

The Throttle Stop Stud is provided for obtaining an even slow running speed.

If it is necessary to adjust this the first step is to slacken off the locknut, then with the engine running adjust the screw until the required setting is obtained. Finally re-tighten lock-nut.

Later type carburetters are not fitted with fuel needle lever, Part No. V257. In such carburetter a different float and a longer fuel needle are fitted and the needle is directly actuated by the float.

HINTS AND TIPS

Do not choke carburetter before starting when the engine is warm.

Stop engine by turning off fuel tap if engine is not to be used for several days.

Do not experiment with cheap sparking plugs, use type recommended.

Always quote full engine number when ordering spares or asking for advice. The number is stamped on crankcase below cylinder base, at rear of engine.

Driving shafts should only be taken apart by a skilled mechanic; special tools are required for ensuring alignment when re-assembling, and as the makers have these facilities, repairs can be undertaken by them at the lowest cost.

It is important that air leaks should be avoided at the following points :

- (a) Between inlet pipe and cylinder.
- (b) Between inlet pipe and carburetter.
- (c) Between cylinder base and crankcase.
- (d) Between the two halves of crankcase.
- (e) Between cylinder and cylinder head.

When decarbonising the engine it is very important that silencers and exhaust pipes are also cleaned out.

Avoid all sharp bends in the carburetter control cables.

VILLIERS MK. 27B. A.C. CARS.

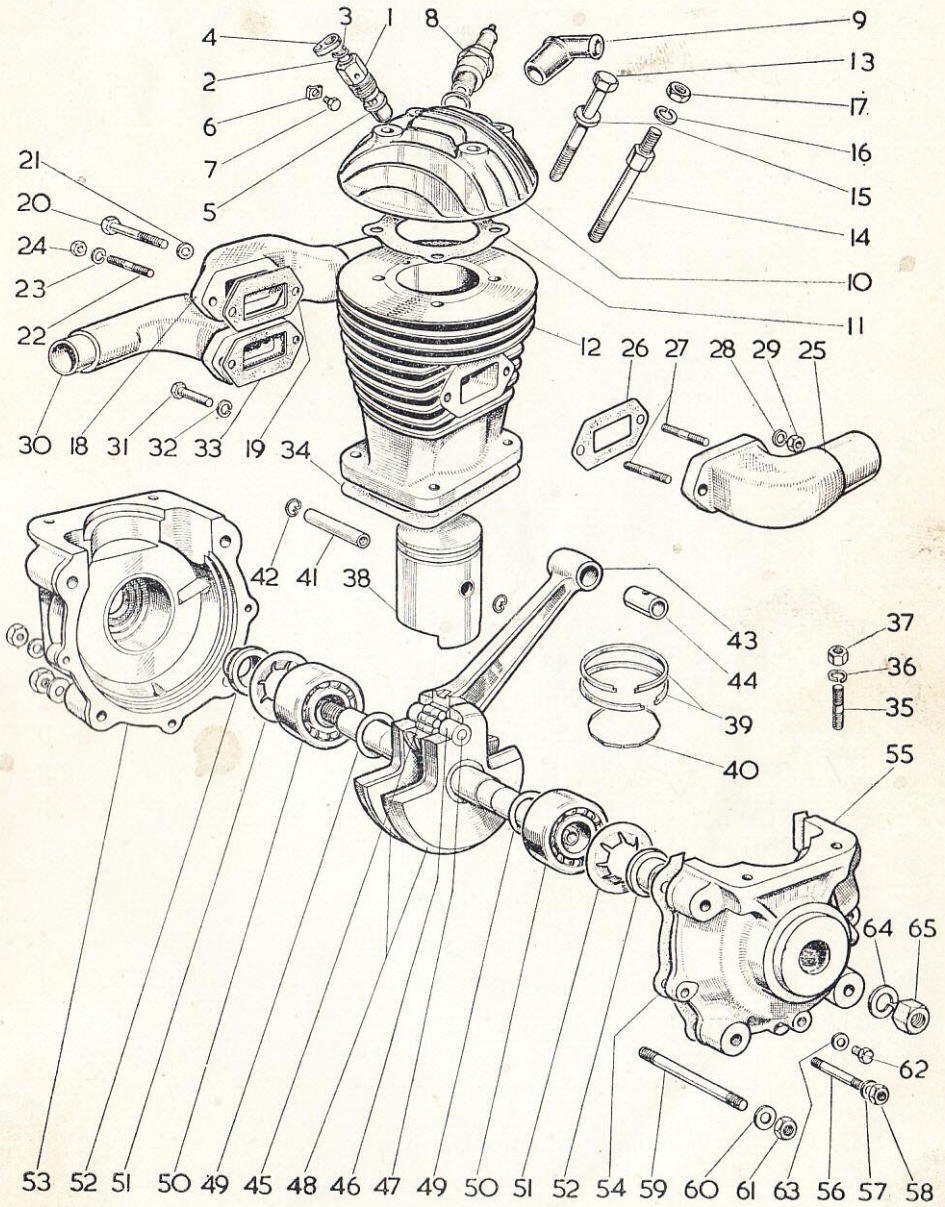

Fig. 3.

Always quote Engine No. when ordering Spares.

SPARE PARTS LIST.
ENGINE Mk. 27B.

<i>Illus. No.</i>	<i>Part No.</i>	<i>Description</i>	<i>No. per Engine</i>	<i>Price each</i> <i>£ s. d.</i>		
1	E.3064	Release Valve Body - - -	1	3	9	
2	E.1280	" " Stem - - -	1	2	0	
3	E.1163	" " Spring - - -	1	3		
4	E.1276	" " Nut - - -	1	1	0	
5	E.3318	" " Joint Washer - - -	1	2		
6	E.1545	" " Clamp - - -	1	9		
7	E.6737	" " " Screw - - -	1	3		
8	HLN 18	Sparking Plug (Lodge) - - -	1		†	
9	M.L. 490E	" " Cover - - -	1	2	6	
10	C.8518	Cylinder Head - - -	1	2	5	0
11	D.40626	" " Compression Plate (Supplied by A.C. Cars)	1	1	3	
12	B.6662/1	Cylinder, less Studs - - -	1	4	5	0
13	E.2442	Cylinder Head Bolt - - -	2	2	6	
14	E.6674	" " " - - -	2	3	0	
15	E.1898	Washer, thick, $\frac{3}{8}$ " - - -	4	1		
16	E.373	" thin, $\frac{3}{8}$ " - - -	2	1		
17	E.834	Nut for Bolt, $\frac{3}{8}$ " - - -	2	2		
18	C.6665	Exhaust Manifold, magneto side - - -	1	1	2	0
19 } 26 }	E.3717	Manifold Joint Washer - - -	2	4		
20	E.6714	Bolt for Manifold - - -	1	1	0	
21	E.2667	Plain Washer for Bolt, $\frac{5}{16}$ " - - -	1	1		
22 } 27 }	E.363	Stud for Manifold - - -	3	3		
23 } 28 } 32 } 36 }	E.1050	Spring Washer, $\frac{5}{16}$ " - - -	9	1		
24 } 29 } 37 }	E.364	Nut, $\frac{5}{16}$ " - - -	7	2		
25	C.3748	Exhaust Manifold, drive side - - -	1	1	2	6
30	C.6667	Inlet Manifold - - -	1	1	5	0
31	FG.151	Manifold Bolt - - -	2	6		

† Manufacturers' Current Price.

<i>Illus.</i> <i>No.</i>	<i>Part</i> <i>No.</i>	<i>Description</i>	<i>No. per</i> <i>Engine</i>	<i>Price each</i> <i>£ s. d.</i>		
33	E.3718	Manifold Joint Washer - - -	1			2
34	D.3719	Cylinder Base Washer - - -	1			4
35	E.2152	„ Base Stud - - -	4			3
38	C.6664	Piston, standard size - - -	1	1	15	0
38	C.7252	„ .015" oversize - - -	1	1	15	0
38	C.7253	„ .03" „ - - -	1	1	15	0
39	E.6659	Compression Ring, standard size - - -	2	1		9
39	E.7233	„ „ .015" oversize - - -	2	1		9
39	E.7234	„ „ .03 „ - - -	2	1		9
40	E.8543	Pressure Ring - - -	1	1		0
41	E.6666	Gudgeon Pin - - -	1	3		0
42	E.4047	„ „ Circlip - - -	2			3
43	D.1412	*Connecting Rod with Bush - - -	1	1	0	0
44	E.1170	Small End Bush only - - -	1	2		6
45	E.7453	*Connecting Rod Rollers - - -	28			3
46	E 7440/1	*Crankpin - - -	1	6		0
47	E.5593	„ Plug - - -	2			3
48	D.6388/1	*Driving Shaft - - -	2	2	5	0
49	E.5071/1	Bearing Shim - - -	2			2
50	3305	Ball Bearing - - -	2			†
51	E.4531	Gland Spring - - -	2			9
52	E.6235	„ Bush - - -	2	6		0
53	B.6366	Crankcase, magneto side - - -	1	3	0	0
54	D.2810	„ Joint Washer - - -	1			2
55	B.6367	„ drive side - - -	1	3	0	0
56	E.3392	„ Joint Stud - - -	3			5
57	E.2924	Plain Washer, ¼" - - -	6			1
58	E.401	Nut for Stud, ¼" - - -	6			2
59	E.1482	Engine Fixing Stud - - -	4			9
60	E.373	Plain Washer, ⅜" - - -	8			1
61	E.834	Nut for Stud, ⅜" - - -	8			2
62	E.1962	Crankcase Drain Screw - - -	2			3
63	E.1905	Joint Washer - - -	2			1
64	E.424	Driving Shaft Washer - - -	1			1
65	E.422	„ „ Nut - - -	1			6

† Manufacturers' Current Price.

* Not supplied separately.

VILLIERS MK. 27B. A.C. CARS.

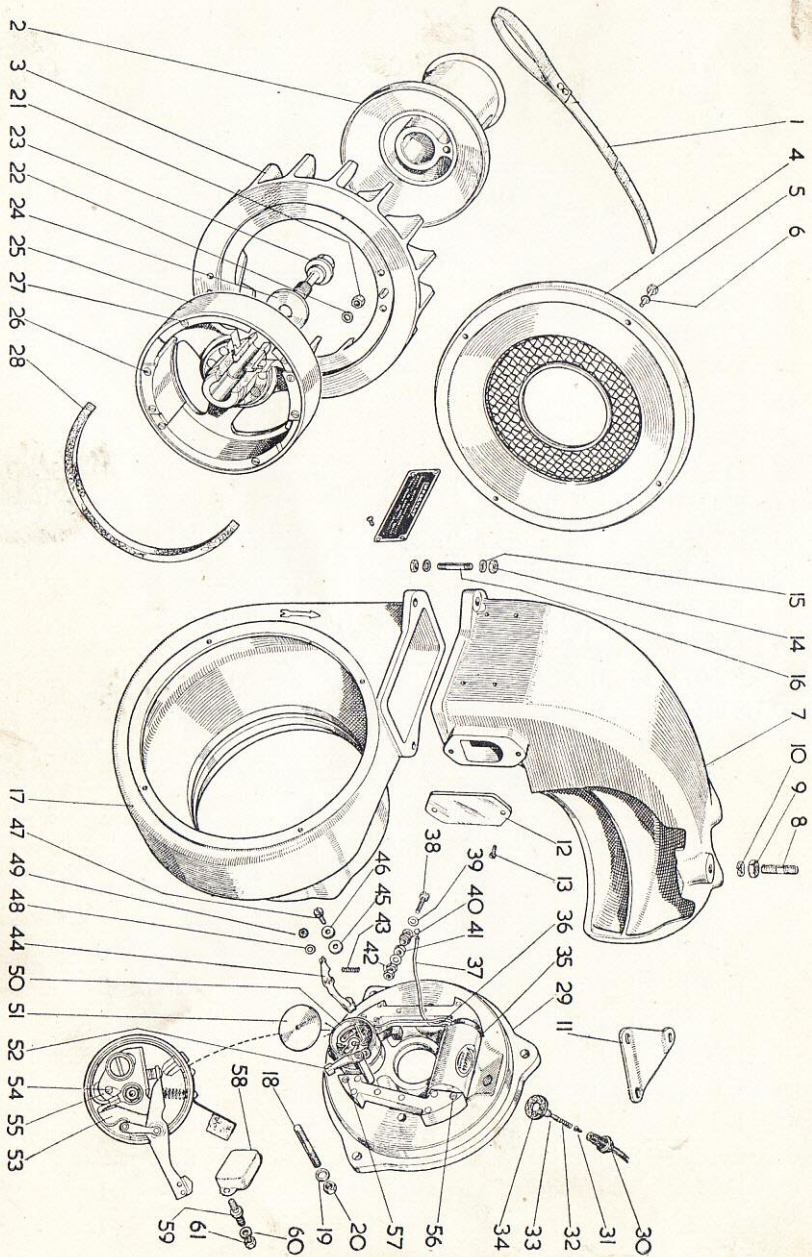

Fig. 4.

Always quote Engine No. when ordering Spares.

<i>Illus. No.</i>	<i>Part No.</i>	<i>Description</i>	<i>No. per Engine</i>	<i>Price each</i> <i>£ s. d.</i>
1	D.5877	Starting Strap - - - - -	1	4 9
2	C.6223	Starter Pulley - - - - -	1	1 10 0
3	CM.208	Fan - - - - -	1	1 10 0
4	C6777	Cowl Front with Gauze - - -	1	17 6
5	E.4659	Fixing Screw Cowl Front - - -	4	3
6	FG.161	Cowl Front Washer - - - - -	4	1
7	B.6668/1	Cowling, top portion - - - - -	1	2 10 0
8	E4160	Cowl Top Stud - - - - -	1	3
9	E.364	„ „ „ Nut - - - - -	1	2
10	E.1050	„ „ „ Washer - - - - -	1	1
11	D.6286	Cylinder Head Strap - - - - -	1	1 3
12	E.6688	Cowl Cover Plate - - - - -	1	2 6
13	EG.527	„ „ „ Screws - - - - -	2	3
14	E.401	„ Stud Nut - - - - -	4	2
15	E.2924	„ Stud Washer - - - - -	4	1
16	E.5107	„ Joint Stud - - - - -	2	3
17	B.6458	Cowling, bottom portion - - -	1	3 10 0
18	E.5294	Cowl Fixing Stud - - - - -	3	3
19	E.2924	„ „ „ Washer - - - - -	3	1
20	E.401	„ „ „ Nut - - - - -	3	2
21	E.2539	Nut for Fan Fixing Screw - - -	4	2
22	E.2924	Washers for Fan Fixing Screw -	4	1
23	E.8926	Starting Pulley Bolt - - - - -	1	2 0
24	FG.163	„ „ „ Washer - - - - -	1	3
25	R.236	Flywheel Assembly less Fan & Pulley	1	3 10 0
26	M.1170	Fan Fixing Screw - - - - -	4	6
27	1002 × 9	Distance Piece Screw - - - - -	4	3
28	E.6342	Felt Liner for Cowling - - - -	2	1 0
29	A.1	Armature Plate Assembly - - -	1	4 10 0
30	1124 × 8	High Tension Terminal - - - - -	1	1 0
31	491	„ „ Pick-up Screw - - - - -	1	2
32	1010 × 11	„ „ Pick-up Spring - - - - -	1	1
33	1046 × 13	„ „ Pad - - - - -	1	2
34	E.869	„ „ Terminal Felt Washer - - -	1	2

SPARE PARTS LIST.
MAGNETO, Mk. 27B.

<i>Illus. Part</i>	<i>No. No.</i>	<i>Description</i>	<i>No. per Engine</i>	<i>Price each</i>		
				£	s.	d.
—	1148 × 4	High Tension Lead, complete	1	4	0	0
35	459	„ „ Coil	1	1	15	0
36	482	L.T. Lead (coil to con. box)	1			6
37	—	„ „ (coil to cut-out terminal)	1			6
38	1113 × 3	„ Terminal Screw (cut-out)	1			9
39	1113 × 5	Plain Washer Terminal Screw	3			1
40	1013 × 13	Cut-out Insulating Bush	1			5
41	1013 × 12	„ „ Washer	1			5
42	1113 × 4	Nut for Cut-out Terminal Screw	2			2
43	1047 × 3	Rocker Arm Spring	1			2
44	M1632	Rocker Arm with Point and Pad	1	4	0	
45	M.1805	Point Bracket Lock Screw Insulating Washer	1			1
46	M.1802	Point Bracket Lock Screw Plain Washer	1			1
47	M.1801	Point Bracket Lock Screw	1			2
48	1113 × 5	„ „ Washer	1			1
49	1113 × 4	„ „ Nut	1			2
50	M.2503	Condenser Box Assembly, complete	1	18	6	
—	M2506	Condenser Box only with Condenser and Studs	1	10	0	
51	1015 × 7	Condenser Box Cover	1			6
52	1015 × 6	„ „ „ Post and Clip	1			6
53	M.2309	Insulating Pad	1			4
54	M.2311	Point Bracket Cam	1			6
55	M.2313	Point Brackets	1	2	3	
56	1030 × 8	Cheek Screw, long	2			3
57	1124 × 9	„ „ short	2			3
58	M.1750	Condenser	1	4	9	
59	1053 × 1	„ Box Stud	2			3
60	1002 × 13	$\frac{3}{16}$ " Washer	7			1
61	1002 × 15	$\frac{3}{16}$ " Nut	7			2
—	D.5979	Sparking Plug Spanner	1	2	0	
—	M.1665	Point Screwdriver	1			7
—	Z1015 × 2	C/Nut Spanner	1	5	0	
—	E3815/6	Box Spanner	1	2	6	

VILLIERS MK. 27B. A.C. CARS.
 CARBURETTER CHOKE CONTROL.

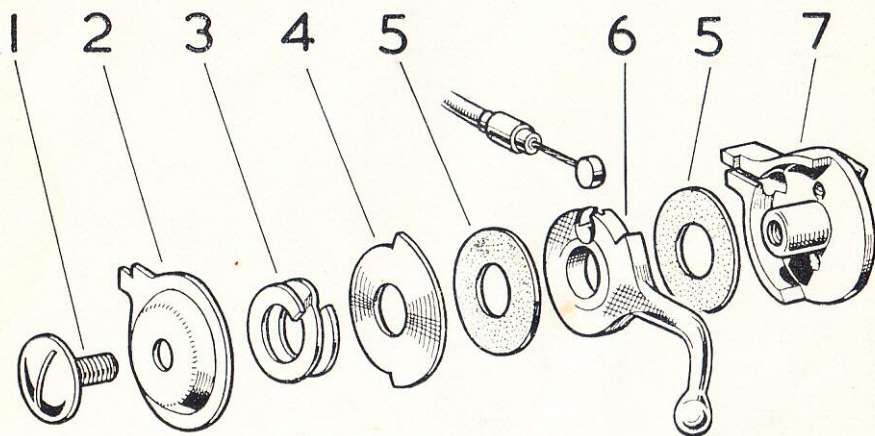

Fig. 5.

<i>Illus. No.</i>	<i>Part No.</i>	<i>Description</i>	<i>No. per Engine</i>	<i>Price each £ s. d.</i>
1	V.117 × 5	Top Cover Screw	1	8
2	V.387	Top Cover	1	6
3	V142 × 11	Control Spring Washer	1	2
4	V.429	Friction Plate	1	6
5	V.142 × 10	Fibre Washers	2	1
6	V.1023E	Lever	1	3 0
7	V.405	Body	1	3 6
—	V.951	Cable Assembly	1	5 0

TYPE S24 CARBURETTOR.

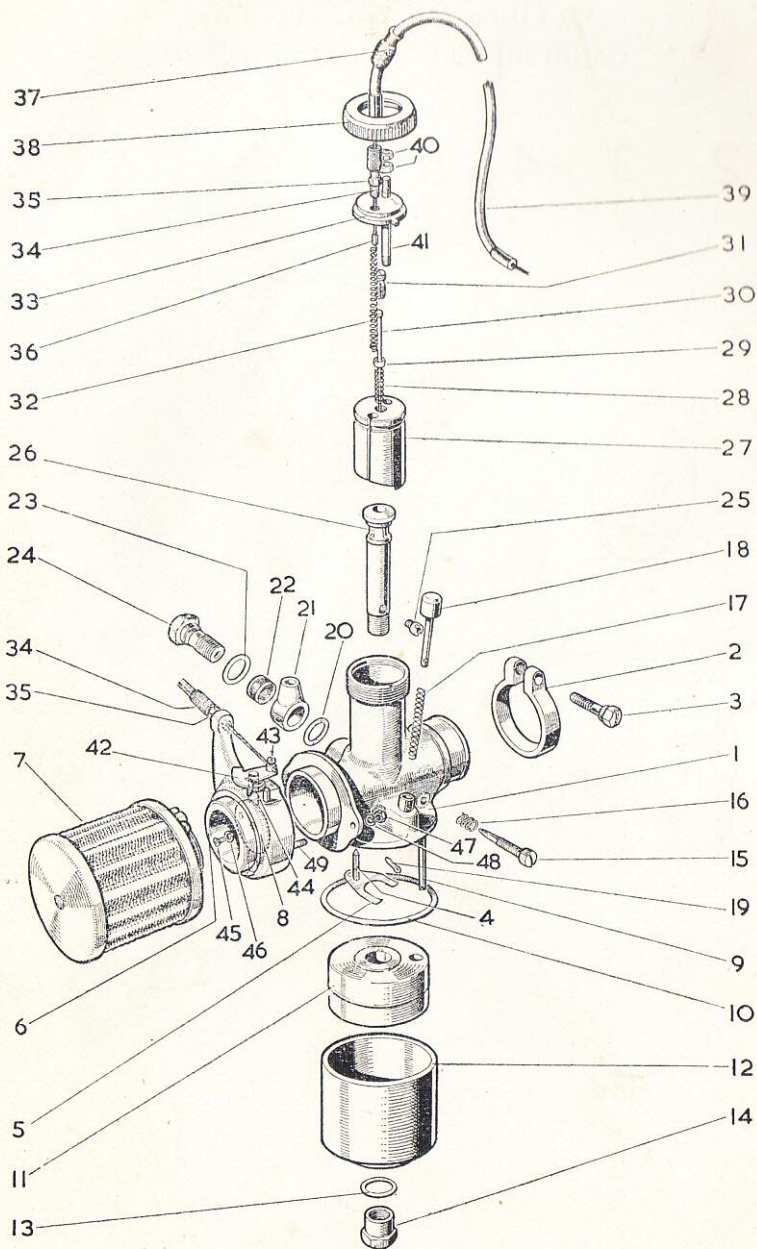

Fig. 6.

Always quote Engine No. when ordering Spares.

SPARE PARTS LIST. CARBURETTER. MK.27B.

Illus. No.	Part No.	Description	No. per Engine	Price each		
				£	s.	d.
1	V.949	Body with Fuel Bush	1	1	7	6
2	V.113 × 14	Body Clip	1		2	3
3	V.754	” ” Screw	1			6
4	V.355	Fuel Needle	1			10
5	V.257	” ” Lever	1			3
6	V.942	Strangler Body	1	15		0
7	V.639	Air Filter	1	12		6
8	V.946	Strangler Plate	1		1	0
9	V.717	Pilot Jet	1		1	0
10	V.125 × 8	Cup Joint Washer	1			2
11	V.777	Float	1	5		0
12	V.773	” Cup	1	3		0
13	V.107 × 3	Bottom Nut Washer	1			1
14	V.361	Bottom Nut	1		1	0
15	V.775	Pilot Jet Needle	1			9
16	V.749	Spring for Needle	1			2
17	V.369	Tickler Spring	1			2
18	V.207	Tickler	1			9
19	V.111 × 2	” Split Pin	1			1
20	V.383	Washer, small hole	1			1
21	V.381	Banjo Union	1	2		0
22	V.404	Filter Gauze	1			8
23	H.104 × 8	Washer, large hole	1			1
24	V.382	Banjo Bolt	1	1		3
25	V.774	Main Jet, Centrepiece	1			6
26	V.772	Centrepiece	1	4		6
27	V.940	Throttle	1	5		0
28	V.801	Needle Spring	1			3
29	V.787	” Collar	1			2
30	V.748	Taper Needle No. 3½	1			9
31	V.786	Needle Adjuster	1			6
32	V.586	Throttle Spring	1			3
33	V.941	Top Disc	1	1		9
34	V.105 × 1	Cable Adjuster	1			8
35	V.105 × 2	Adjuster Locknut	1			1
36	V.108 × 15	Cable Nipple	1			1
37	V.826	” Cover	1			4
38	V.107 × 5	Top Ring	1	1		6
39	V.1026	Control Cable Assembly	1	5		0
40	V.105 × 2	Throttle Stop Stud Locknuts	2			1
41	V.914E	” ” Stud	1			3
42	V943	Strangler Spindle and Lever	1	3		0
43	V145 × 14	” Cable Screw	1			2
44	V.947	” Return Spring	1			6
45	EM.362	” Plate Screw	1			2
46	—	” Spring Washer	1			
		¼” Single ” Coil	1			1
47	1113 × 4	Nuts, Strangler Body Fixing Studs	2			2
48	E.7529	Spring Washer, Strangler Body Fixing Studs	2			1
49	V.948	Strangler Body Fixing Studs	2			3

NOTE.—On later Engines items 4, 5 and 11 are not fitted and are replaced by—

V105 × 13 Fuel Needle - - 10d. V1076E Float - - - - 5/-

GUARANTEE

WE give the following guarantee with VILLIERS Engines and Accessories in place of any implied guarantee by statute or otherwise, all such guarantees being in all cases excluded. No statement or representation contained in this catalogue shall be construed as enlarging or varying this guarantee. In the case of engines and accessories which have been used for "hiring out" purposes, or from which our trade mark, name, or manufacturing number has been removed, no guarantee of any kind is given or is to be implied.

In the case of engines and accessories used for industrial and stationary purposes, this guarantee shall not apply unless the application of the engine has been agreed and approved in writing by us.

We guarantee, subject to the conditions mentioned below, that all precautions which are usual and reasonable have been taken by us to secure excellence of materials and workmanship, but this guarantee is to extend and to be in force for six months only from the date the engines or accessories are despatched by us, and the damages for which we make ourselves responsible under this guarantee are limited to the replacement of a part manufactured by us which may have proved defective.

We do not undertake to refit or bear the cost of replacement or refitting such new part. We guarantee, subject to the conditions mentioned below, to make good at any time within six months any defects in these respects. As VILLIERS Engines and Accessories are liable to derangement by neglect or misuse, this guarantee does not apply to defects caused by wear and tear, misuse and neglect.

CONDITIONS OF GUARANTEE.

If a defective part should be found in our engines or accessories, it must be sent to us carriage paid and accompanied by an intimation from the sender that he desires to have it repaired free of charge, under our guarantee, and he must also furnish us at the same time with the number of the engine, and full particulars of purchase. Failing compliance with the above, no notice will be taken of anything that may arrive, but such articles will lie here at the risk of the sender, and this guarantee or any implied guarantee shall not be enforceable.

THE TERM "AGENT" is used in a complimentary sense only, and those firms whom we style our agents are not authorised to advertise, incur any debts, or transact any business whatsoever on our account other than the sale of goods which they may purchase from us, nor are they authorised to give any warranty or make any representations on our behalf or sell subject to or with any conditions other than those contained in the above guarantee.

The guarantee becomes void if any parts not made or supplied by the VILLIERS ENGINEERING COMPANY, LTD., are fitted to a VILLIERS engine. To safeguard his own interests, the owner should always insist upon genuine VILLIERS parts.

ESTIMATES.

If required, we are always prepared to give an estimate before proceeding with any repair. This entails a certain amount of labour in dismantling to ascertain what new parts will be required, and therefore, in the case of any estimate not being accepted for special reasons, a small charge is made for our mechanic's time in taking down the parts for report.

Estimates must be treated as approximate only. We reserve the right to include additional parts should these be found, on further examination or on bench test, to be necessary, to make the repair satisfactory.

We do not undertake to fit to engines sent to us for overhaul, any parts specified by the customer when we consider that other parts are necessary to make an efficient repair. In such cases, we are prepared to supply the customer's requirements in spares, but we do not undertake to fit them.

IMPORTANT.

1.—When sending parts for replacement, repair, or as pattern, the name and address of the sender should always be securely attached, and full instructions explaining what is required should be sent separately by post. In no circumstances should instructions be enclosed with the parts as they are liable to be lost or damaged in unpacking.

2.—If an engine is sent for repair, it should be well packed in a strong box. Cardboard or a sack is insufficient, and engines so packed are liable to get seriously damaged in transit. Packing cases are not returnable unless specially asked for by the owner at the time of sending to us.

3.—All goods must be consigned to us carriage paid, addressed to "Service Dept." Goods returned by rail are consigned carriage paid.

4.—In correspondence, always quote the engine number and prefixed letter(s) stamped on the crankcase below the cylinder base.

5.—As we are not manufacturers of complete motor cars or other machines, only the engine should be sent to us. If machines are forwarded extra expense will be charged for dismantling the engine from the frame and refitting same.

6.—We prefer to bench test every repaired engine before returning it to its owner. It is, therefore, always advisable to send the engine complete with its magneto, sparking plug and carburetter.

7.—When forwarding a flywheel magneto for overhaul, send the armature plate and the flywheel complete. These parts should in no circumstances be separated, as certain magnetic flux is lost thereby.

8.—Always quote the magneto number and letter(s) (if any) which is stamped on the face of the flywheel, when corresponding about your flywheel magneto.

9.—Old or worn-out parts sent as patterns, which we consider obsolete, are not returned unless specially asked for by the owner at the time of sending them to us.

10.—Any engines or parts sent to our Works for repair not paid for within six months from the date of our estimate, will be offered for sale by us elsewhere to defray expenses.

TERMS OF BUSINESS.

Repairs and spares must always be treated on a cash basis. Ledger accounts will be opened for items of £5 (five pounds) and upwards for approved accounts.

An extra amount must always be included in remittances to cover the cost of postage or carriage and packing on spare parts. This is 5% extra up to £5 value. Minimum extra is 6d. Stamps cannot be accepted for items over 1/- (one shilling) in value.

When making remittances by telegraph money order, the name and address of the sender must be included in the space provided on the Post Office Requisition Form for a private message from remitter to payee. Unless this is done, the Post Office does not give this information upon the telegram.

We are always prepared to send goods by C.O.D. method when requested.

*Printed in England by
Whitehead Brothers (Wolverhampton) Ltd.
St. John's Square
Wolverhampton*

V.E.C. 57.

E. & O. E.

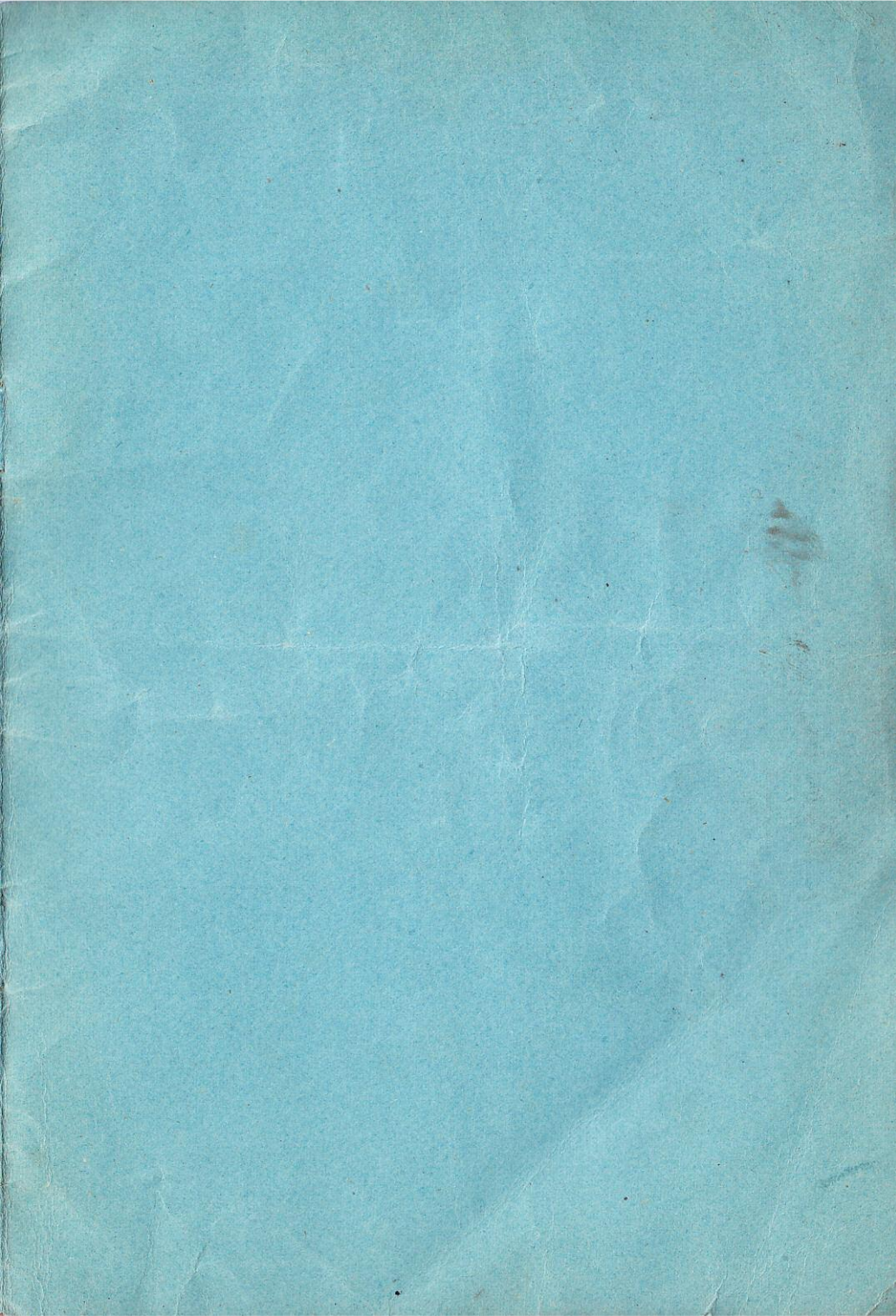

7 Oct 14

76 Boyler Rd

IceniCAM Information Service

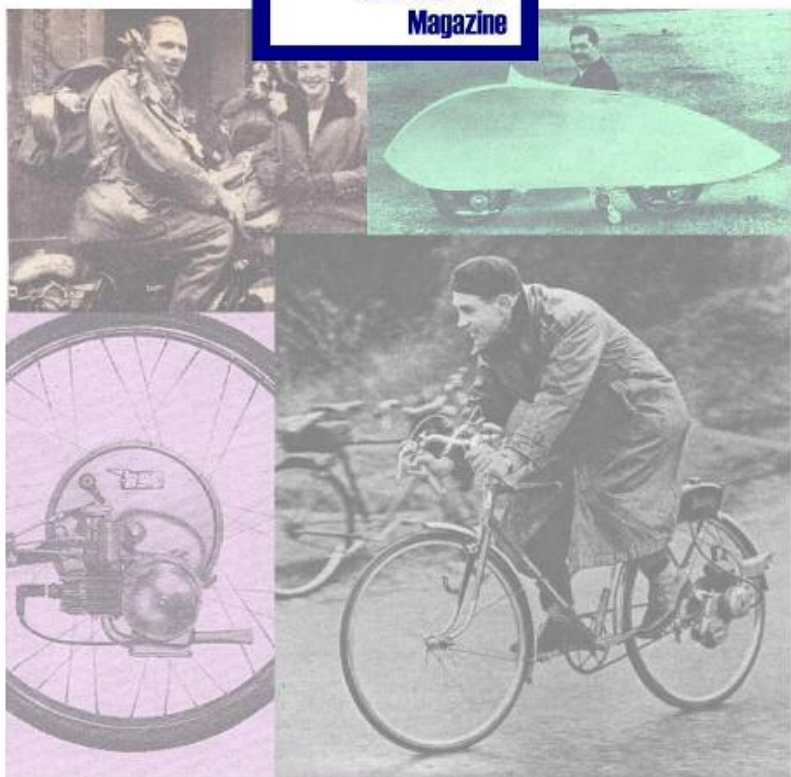

www.icenicam.org.uk