

IceniCAM Information Service

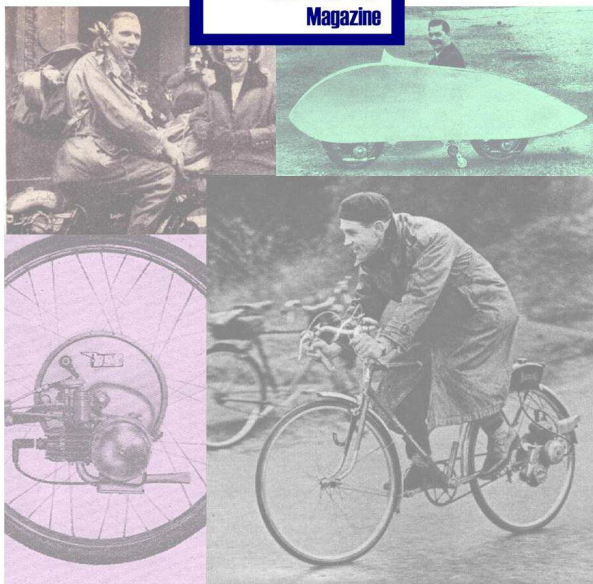

www.icenicam.org.uk



INSTRUCTION MANUAL

for the



AUTOCYCLE

Price 2/-

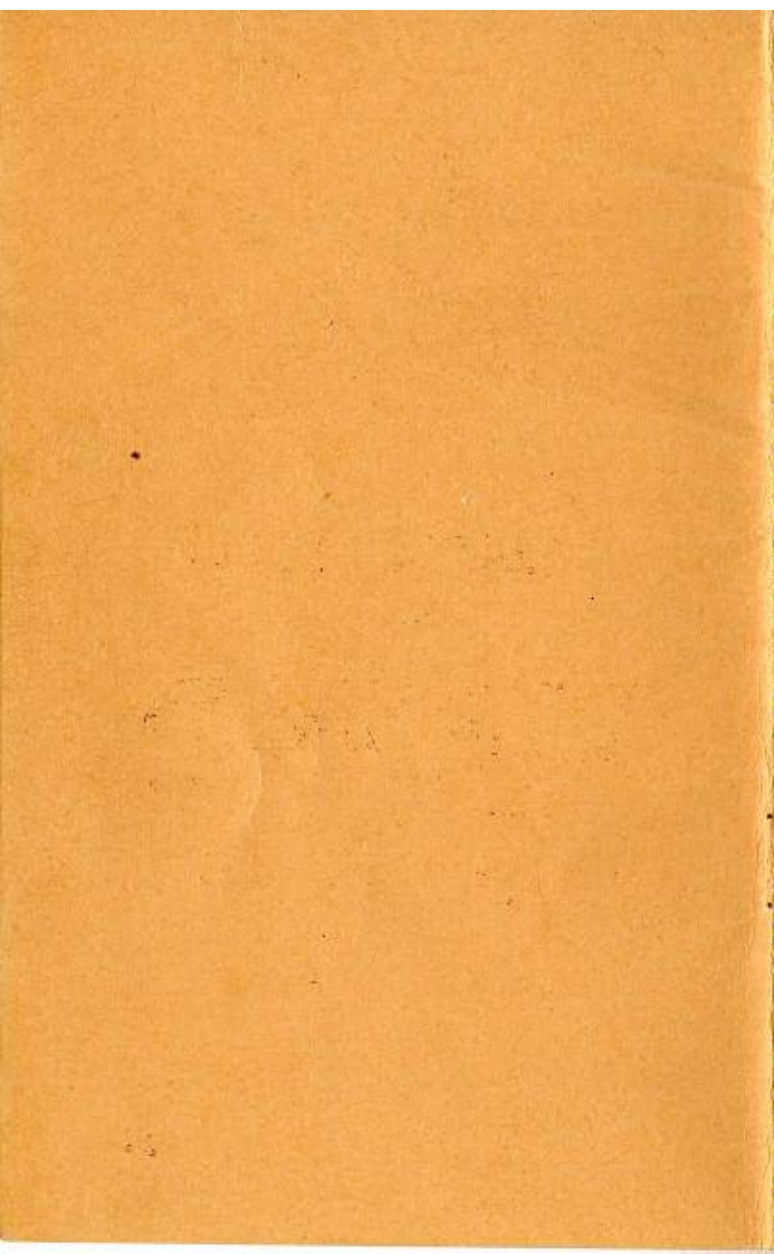

INSTRUCTION MANUAL

for

NEW HUDSON AUTOCYCLE

NEW HUDSON LTD.

Waverley Works, BIRMINGHAM, 10

Directors:

SIR BERNARD DOCKER, K.B.E. (*Chairman*).

J. LEEK, C.B.E.

Telephone: Birmingham Victoria 3711 (6 lines)

Telegrams and Cables: "Newhud," Birmingham

*New Hudson Ltd. reserve the right to alter the designs or any
constructional details of their manufactures at any time
without giving notice.*

NHA141-5

Printed in England

June 1955

INSTRUCTION MANUAL

for

NEW HUDSON

AUTO CYCLE

NEW HUDSON LTD.

NEWARK, N. J.

NEW YORK, N. Y.

NEWARK, N. J.

NEWARK, N. J.

NEWARK, N. J.

CONTENTS

	<i>Pages.</i>
Brakes	21
Carburetter	31
Central Stand	12
Chains	20
Cleaning	10
Clutch	16
Controls	5
Cylinder Head Removal	25
Cylinder Barrel Removal	27
Decarbonising	24
Decompressor	25
Driving	8
Electrical Equipment	34
Forks	13
Hubs	14
Ignition Timing	15
Lighting Set	36
Lubrication Chart	18
Lubrication System	10
Periodical Maintenance	10
Piston Rings	28
Running-in	8
Sparking Plug	21
Steering Head	13
Technical Data	4
Wheel Alignment	21
Wheel Removal (front)	14
Wheel Removal (rear)	14
Wiring Diagram	36

TECHNICAL DATA

Petrol tank capacity	...	1½ galls.
Petrol mixture	20 : 1
Bore	47 m.m.
Stroke	57 m.m.
Capacity	98 c.c.
Ignition timing	Piston distance before t.d.c. with points just opening 1/8 in.
Contact breaker gap015 in.
Piston ring gap007 - .011 in.
Spark plug	H.14
Plug points gap018 - .020 in.
Tyre sizes	2.25 - 21
Tyre pressures	Front	20
	Rear	23
Primary chain (54 pitches)	...	¾ x .155 in.
Pedal driving chain		
(91 pitches)	½ x ⅝ in.
Main driving chain		
(118 pitches)	½ x .192 in.
Standard carburetter jet	J.8
Carburetter taper needle	No. 2½
Carburetter needle setting	29/32 in.

THE CONTROLS

Throttle Control.

Small lever on top of the right handlebar, this controls the speed of the machine. To open the throttle rotate the lever in a clockwise direction.

Decompressor Control.

Small lever attached to the right handlebar, by pulling the lever in towards the bar the compression in the combustion chamber is released. This enables the engine to be rotated easily while starting.

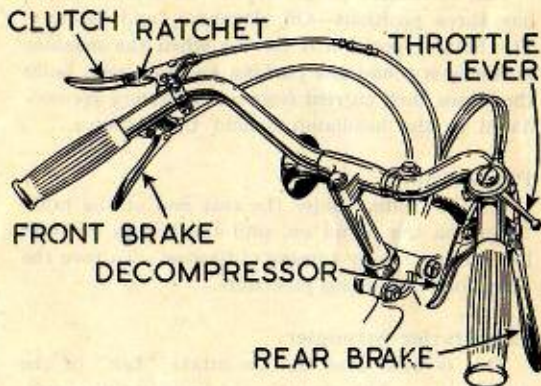

Fig. 1. The Controls.

Rear Brake.

The large lever attached to the right handlebar below the throttle control. To apply the brake pull the lever up towards the handlebar.

Front Brake.

The large lever attached to the left handlebar below the clutch control. To apply the brake pull the lever up towards the handlebar.

Clutch Control.

This is the hand lever clipped to the left handlebar. To declutch (i.e. to disengage the drive between the engine and the rear wheel) pull the lever towards the handlebar. The lever can be held in the released position by a spring loaded ratchet. To engage the clutch pull in the trigger and gently release the lever.

Lighting Switch.

This is situated on the top of the headlamp and has three positions—Off, Dynamo, and Battery. The battery position is for use when the machine is stationary, and the parking and tail-lamp bulbs then draw their current from a dry battery accommodated in the headlamp behind the reflector.

Petrol Tap.

This is located under the rear end of the tank. To switch the petrol on, pull the button out and lock in position by turning clockwise. To turn the petrol off reverse this procedure.

Carburetter Strangler.

This is built into the air intake "bell" of the carburetter. The strangler is brought into operation by raising the wire loop attached to the left-hand side of the petrol tank, thus reducing the air admitted to the carburetter to a minimum and providing a very rich mixture. The strangler should always be kept pushed right down except when starting from cold (see driving instructions page 8).

Central Stand.

This is of the spring up type so that when the machine is pushed forwards off the stand the latter will spring back against the frame member, clear of the road.

Taking the machine out for the first time.

Unless the work has already been carried out by the dealer from whom it was purchased, before attempting to start the machine it is necessary to fill up with petrol and oil and generally to see that the machine is properly lubricated.

The filler cap is marked with instructions as to the correct proportions of petrol and oil, and it also mentions the proprietary brands of oil which we recommend as being suitable for this engine.

For correct running of the engine and also for adequate lubrication, it is essential that the oil should be completely dissolved in the petrol, and therefore it is preferable to mix the two in a separate container before pouring into the tank. If this is not possible, as for instance when obtaining petrol from a wayside pump, the oil should be put in after filling up with petrol, and the machine should be shaken thoroughly to ensure correct mixing of the two liquids. If this is not done there is a risk of liquid oil undiluted with petrol reaching the carburetter and clogging the fuel supply system.

The various parts of the machine which are lubricated by grease as indicated on the lubrication charts on pages 18 and 19 should also receive attention at this stage by the application of a grease gun to the nipples marked on the diagram.

DRIVING

To Start the Engine.

Take the machine off the stand. If the engine is cold, first depress the carburetter tickler momentarily and close the strangler by lifting the wire loop. Open the throttle control lever about one third of its total movement, and squeeze the decompressor lever. Sit astride the machine and pedal away. The engine will start as the decompressor lever is released.

During normal running the strangler must always be kept fully open and it should be opened immediately the engine fires, or should the weather be cold, at the earliest possible moment (see special note, page 33).

Note: While it is necessary to close the strangler when starting from cold, this may not be needed when the engine is warm and should certainly not be necessary if the engine is restarted after a short halt.

To Stop.

Close the throttle control lever, and apply the brakes as necessary. Disengage the clutch as the machine comes to rest, otherwise the engine will stop.

Stopping the Engine.

Close the throttle control lever, pull the decompressor lever in towards the bar and do not release until the engine comes to rest.

HINTS ON RUNNING-IN A NEW AUTOCYCLE.

The rider who has just purchased a new machine for the first time will do well to remember that all

the hidden working parts are just as new as the enamel and plating which he can see, and that they must not be overloaded until they are well run-in.

This running-in is really the most important period in the life of the engine, and the handling it receives during the first 500 to 1000 miles will determine what sort of service it is going to give later.

It is advisable not to exceed half throttle during the first 500 miles. The machines maximum will then not disappoint you. If you try to put it through its paces too soon you will run the risk of seizure and other troubles which may have a lasting effect on the engine, and, in any case, until it is really run-in it will not be at its best.

Avoid sudden and sharp acceleration, especially when the engine is not pulling under load.

Do not force it up hills when a small amount of pedalling would ease the load.

After the first 250 miles (400km), remove the hexagonal headed screw at the bottom of the crankcase (left-hand side) and drain out any oil which may have accumulated there. With the petroil lubrication system employed there is never a considerable quantity of liquid oil in the crankcase, but whatever oil is there should be drained away, and this is preferably done while the engine is warm, immediately after a run, as the oil will flow more freely and carry with it any foreign matter which may have found its way into the crankcase during the running-in process.

Make certain on replacing the plug that it is made really tight in order to prevent loss of crankcase compression.

Information regarding the correct grades of oil is given in the chart on page 18.

LUBRICATION

The proportion of oil to petrol recommended for the engine petrol lubrication system, is 20 parts of petrol to one part of oil, and this mixture strength is sufficient to provide adequate lubrication throughout the life of the engine. If Self Mixing or Ready Mixed two stroke oils are used, the ratios employed should be in accordance with the chart on page 18.

Lubrication of certain other parts of the machine such as forks, and hubs is by grease gun, and these are outlined in the following section, entitled "Periodical Maintenance".

Other parts calling for attention with an oil can are also given in this section, and all these lubrication points are indicated on the diagram on page 18 where recommendations for the most suitable lubricants will also be found.

PERIODICAL MAINTENANCE

Weekly Cleaning.

Obviously, regular and thorough cleaning will keep your machine looking smart and will help to retain both its new appearance and value. But it also helps to lengthen its life and maintain efficiency if the cleaning process is carried out correctly.

Take special care to prevent dust and grit from working into such parts as hubs, carburetter, magneto, brakes.

To rub dry and caked mud from the frame, tank and mudguards means that the enamel on these parts will be subjected to an abrasive action which will quickly destroy the polish. Soak the mud first, and then float it off with copious supplies of clean water supplied either with a hose or a sponge. If a hose is used, take care not to direct the stream of water directly on to the hub bearings, magneto or carburetter.

When all dirt is removed, dry and polish off with a clean duster.

The engine is best cleaned with a brush and petrol, and then dried off with clean rag.

Tyres.

Examine carefully for cuts and remove any flints or metallic scraps which may have become embedded in the rubber. Check the pressures with a gauge, and rectify if necessary.

Front Forks.

Give a few strokes of the grease gun.

Control Joints and Exposed Cables.

Give a few drops of oil.

EVERY 500 MILES (750 km)

Clutchcase.

Inspect oil level by removing level screw B Fig. 4. To top up remove oil filler screw A, and fill up until oil issues from B. See lubrication recommendations page 18.

Pedals and Bottom Bracket.

Apply a few drops of oil.

EVERY 1000 MILES (1500 km.)

Hubs.

Inject grease through the nipples in the centres of the hubs, do not over lubricate, or grease may be forced on to the brake linings and cause ineffective brakes. Two or three strokes of the grease gun should be ample. **Do not lubricate with oil.**

Steering Head.

Lift the front of the machine and place a box under the crankcase so that the front wheel is clear of the ground. Test for play in the steering head by trying up and down movement. Check also that the steering is free. If necessary adjust as explained on page 13.

Brake Cam Spindles.

A few drops of oil are all that is needed.

Clutch Adjustment.

There must always be a slight amount of play in the clutch withdrawal mechanism in the clutch case and a short length of free cable at the handle-bar lever end. If the play becomes excessive difficulty will be experienced in disengaging the drive, as the clutch may not fully disengage, in which case the control should be adjusted as explained on page 16.

Chains.

Adjust the main and pedal driving chains as described on pages 20. The front chain runs on short fixed centres and adjustment is not required.

EVERY 2000 MILES

Primary Chain Lubrication.

This has a common oil supply with the clutch case and therefore requires no separate attention beyond the instructions given for the clutch case.

Central Stand.

A few strokes of the grease gun.

HOW TO CARRY OUT THE VARIOUS ADJUSTMENTS NECESSARY FOR CORRECT RUNNING

Forks.

The link bolts must be kept just tight enough to prevent side play at the hubs. Slacken the locknuts *C* (Fig. 2) and adjust the forks by tightening the link bolts *D*, until all the side play is taken up. As each bolt is adjusted check the free action of the fork, then tighten the locknut and re-check the adjustment.

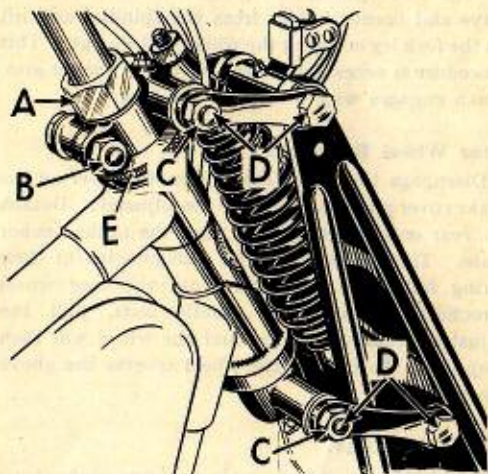

Fig. 2. The Front Forks and Steering Head

Steering Head.

It is first necessary to lift the front wheel clear of the ground—this can be done by lifting the

machine on its stand and putting some small weight on the saddle or carrier causing the rear wheel to rest on the ground. Slacken the clip bolt *A*, and locknut *B*, (Fig. 2). Turn the knurled adjusting ring *E*, until any slackness has been taken up. Do not overtighten or the steering will be stiff and the ball races may be damaged. Finally re-tighten the locknut *B*, followed by the clip bolt *A*, and recheck the adjustment.

Front Wheel Removal.

Disengage the brake cable from the lever on the brake cover plate, and unscrew the adjuster. Take off the two spindle nuts, remove the mudguard stays and licence holder from the spindles and lift up the fork leg enabling the wheel to drop out. This procedure is necessary to free the brake anchor arm, which engages with a stop on the fork.

Rear Wheel Removal.

Disengage the brake cable from the lever on the brake cover plate and unscrew the adjuster. Detach the rear end of the silencer from the brake anchor plate. The chains should be disconnected at their spring links and unwound from the rear wheel sprockets. Slacken the spindle nuts, pull the adjusters from their stays and the wheel will then drop out. To replace the wheel reverse the above procedure.

Wheel Bearings.

The hubs are fitted with cup and cone type bearings, and periodically, say every 2,000 miles, it is advisable to check the adjustment. The following procedure should be adopted when adjustment is required. This can only be carried out in a satisfactory manner when the wheels are removed.

Front Wheel.

The locknut *A*, (Fig. 3) should be undone and the locknut *B*, slackened or tightened as necessary. It is most important that this nut is not over-tightened as when the adjustment is complete the wheel must have just perceptible side play at the rim. When this setting is obtained, re-tighten the locknut *A*, against the adjusting nut *B*, and finally re-check.

Rear Wheel.

The adjustment of the rear wheel is carried out in exactly the same manner as described above.

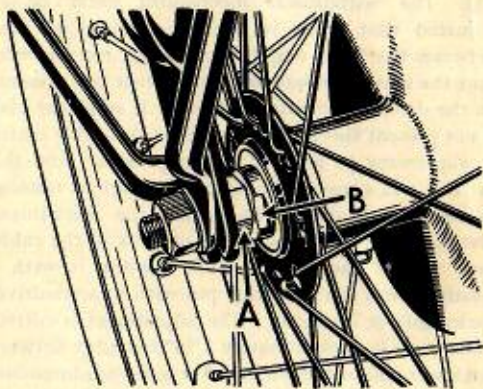

Fig. 3. Front Hub Adjustment.

Ignition Timing.

It is advisable after adjusting the flywheel magneto (see page 34) to check the ignition setting, first remove the magneto cover by undoing the three

screws. The timing marks are stamped on both the armature plate and flywheel rim. To check the actual timing remove the sparking plug and turn the engine until the piston is felt to be at top dead centre by means of a suitable rod inserted through the sparking plug hole. Turn the flywheel until the timing marks coincide, the piston should then be $\frac{1}{8}$ in. before top dead centre.

Clutch Adjustment.

The clutch adjuster will be found on the right-hand side of the clutch case see (Fig. 4). It consists of an adjusting pin *D*, and a locknut *C*, to secure it in position. The pin is the pivot for the clutch withdrawal lever which operates the clutch push rod. The withdrawal mechanism must be so adjusted that there is a slight amount of play between the lever and the operating rod in order that the clutch springs may exert their full pressure on the driving and driven plates. If sufficient play is not present there will be a tendency for the clutch to slip owing to reduced spring pressure, and this in turn will cause overheating and serious damage to the clutch itself. To adjust the mechanism, first make sure there is plenty of slack in the cable, then release the locknut and, holding it with a spanner, turn the adjusting pin with a screwdriver backwards or forwards. The adjustment is correct when there is approximately $3/16$ " free play between the lower end of the clutch lever and the aluminium cover. Tighten the locknut and recheck the adjustment. The clutch cable must be re-adjusted whenever the clutch adjustment has been altered.

Clutch Cable Adjustment.

The cable adjuster will be found near the clutch lever on the left handlebar. There should be a

small amount of play (about $\frac{1}{8}$ ") at the handlebar lever end, if not, adjust as follows:—

Slacken the locking nut and screw the barrel of the adjuster out of the body to tighten the cable. Re-tighten the locknut.

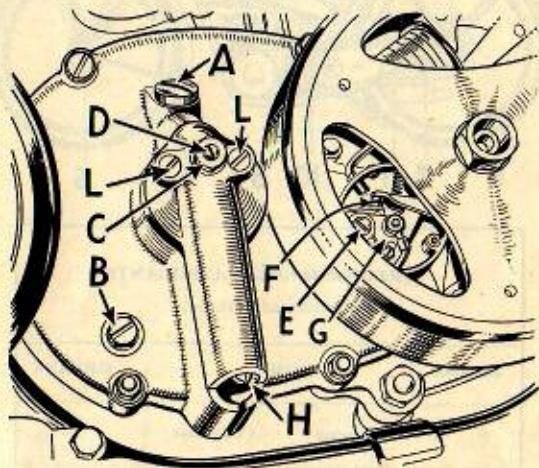
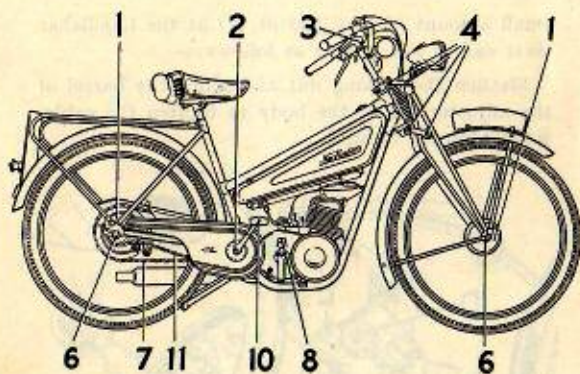

Fig. 4.

Renewing the Clutch Cable.

If the clutch cable requires renewing at any time the following procedure should be adopted:—

Remove the cable from the handlebar lever. Next remove the two screws *L*, (Fig. 4), so that the clutch lever cover can be removed. Detach the cable from the lever at *H*. Finally replace the cover and the screws *L*. It must be realised that whenever a new clutch cable has been fitted the cable must be re-adjusted as explained on page 16.



RECOMMENDED LUBRICANTS

(Summer and Winter)

BRAND	OIL		GREASE
	Engine	Clutchcase	
B.P.	Energol S.A.E. 30	S.A.E. 140	Energrease C3
Essolube	30	Esso Gear Oil 140	Esso Grease
Mobiloil	A	Mobilube C	Mobilgrease No. 2
Shell	*X100-30	Shell Spirex C	Retinax A or C.D.
Castrol	XL	Castrol D	Castrolsease Heavy

* Alternative recommendation 'Petrol-oil Mixture'

WEEKLY LUBRICATION

<i>Ref.</i>	GREASE	<i>Page</i>	<i>Ref.</i>	OIL	<i>Page</i>
4	Front Fork	11	3	Control Joints	11
			—	Exposed Cables	11

LUBRICATION EVERY 500 MILES

<i>Ref.</i>	GREASE	<i>Page</i>	<i>Ref.</i>	OIL	<i>Page</i>
			2	Bottom Bracket	—
			10	Pedals	—
			8	Clutchcase	11

LUBRICATION EVERY 1,000 MILES

<i>Ref.</i>	GREASE	<i>Page</i>	<i>Ref.</i>	OIL	<i>Page</i>
6	Hubs	11	1	Brake Cam Spindles	11

LUBRICATION EVERY 2,000 MILES

<i>Ref.</i>	GREASE	<i>Page</i>	<i>Ref.</i>	OIL	<i>Page</i>
			7	Main Driving Chain	12
			11	Pedal Driving Chain	12

Chain Adjustment.

The chains are adjusted as follows:—

Slacken the nut *C* on pedal driving chain adjuster, (Fig. 5). Slacken off the spindle nuts *A*, and screw the adjusters *B*, in or out until the main driving chain has $\frac{3}{4}$ " up and down movement, in the centre of the chain at its tightest point. Make sure that the adjustment is equal on both sides of the wheel. Finally tighten the spindle nuts. Raise the arm *D*, by its forward end until the pedal driving chain has $\frac{1}{4}$ " up and down movement in the centre of the chain at its tightest point. Finally while holding the arm *D*, firmly against the bracket, tighten the nut *C*.

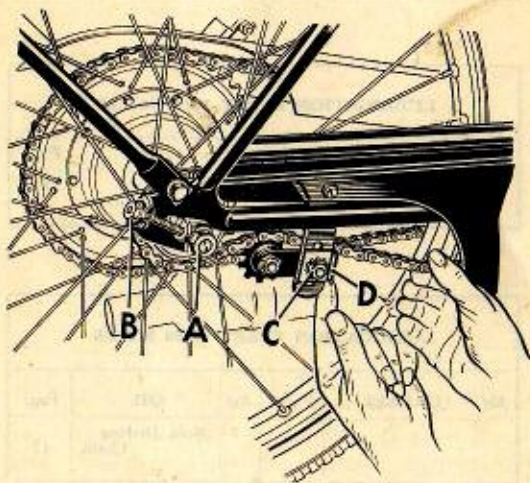

Fig. 5. Chain Adjustment.

Wheel Alignment.

Whenever any adjustment has been made to the chains it is advisable to examine the wheels for alignment, since if this is incorrect the steering will be unsatisfactory and undue wear will take place on the sprockets, chains tyres etc. Check that the chain adjusters are firmly against their stops and that the adjustment is equal on both sides of the wheel, so that the latter is in correct alignment with the frame. This can be done either by glancing along the line of both wheels when the front wheel is set straight, or by means of a long straight edge or a plank placed along the side of the wheels. The straight edge should touch both the front and rear of both wheels.

It is a good plan periodically to remove the chains, clean them thoroughly in petrol or paraffin and then gently warm them in a mixture of grease and graphite. When cool wipe off the excess grease, clean sprockets and replace. Remember when replacing chains that the detachable spring link must always be put on with the closed end facing the direction of travel of the chain, i.e., forwards on the top run.

Brakes.

The brakes are adjusted by means of the screwed adjuster on the cable stop attached to the brake cover plates, and a few turns are all that is necessary to improve braking efficiency.

Sparkling Plug.

The sparking plug is of great importance in obtaining satisfactory engine performance, and every care should be taken to fit the correct type when replacements are necessary. The plug fitted

to this engine is Lodge type H.14 as illustrated in (Fig. 6). Remove the sparking plug every 500 miles (750 km.), or so, for inspection. If the carburation system is in correct adjustment the sparking plug points should remain clean almost indefinitely. An over rich mixture from the carburetter will however cause the formation of a sooty deposit on the points, and later on the plug end face (as upper views Fig. 6). If therefore such a deposit is found,

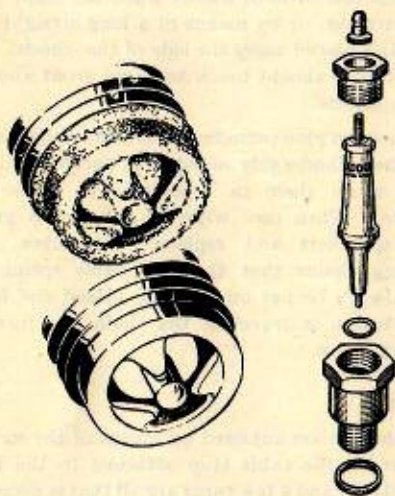

Fig. 6. The sparking plug.

clean it off carefully and check the carburetter. Too high a proportion of oil in the petrol mixture will also cause plug fouling. The continued use of leaded fuel may also eventually produce a deposit on the plug, this time of a greyish colour.

A light deposit due to any of these causes can easily be cleaned off but if it is allowed to accumulate, particularly inside the body, the plug may spark internally with an adverse effect on engine performance and may stop the engine altogether. The plug should be cleaned and tested at regular intervals, and it is suggested that this service be performed at your garage on a special air blast service unit. If eventually the service cleaning process fails to restore the plug to its original condition of efficiency, it should be replaced by a new one.

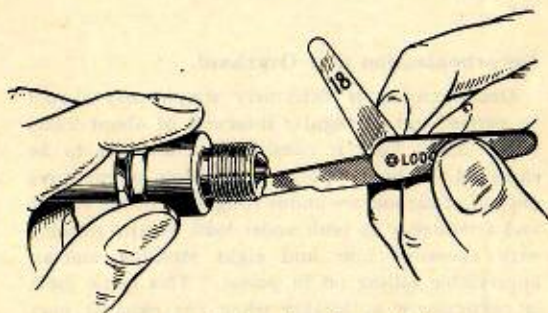

Fig. 7. Setting the plug points.

When inspecting a plug, also check the gap between the points. This should be .018—.020 in. (.45—.50 mm.) and adjustment should be made by bending the side wires (Fig. 7). **Never attempt to remove the centre electrode.** It is always advisable to use the special gap tool illustrated, obtainable from any Lodge plug stockists or from Lodge Plugs Ltd., Rugby.

Feeler gauges are attached to verify correct gap. When refitting a plug, make sure that the copper

washer is not defective in any way. If it has become worn and flattened, fit a new one to ensure a gas tight joint.

Screw the plug down by hand as far as possible, then use a spanner for tightening only. Always use the special spanner provided to avoid possible fracture of the insulator, and do not in any circumstances use a movable spanner.

Paint splashes, accumulation of grime and dust, etc. on the top half of the insulator, are often responsible for poor plug performance. The plug should therefore be wiped frequently with a clean rag.

Decarbonisation and Overhaul.

Decarbonising is extremely simple and should be carried out at regular intervals of about 2,000 miles (3,500 km.) if consistent results are to be expected. The symptoms indicating an excessive deposit of carbon are undue roughness of the engine and a tendency to pink under load, erratic running with excessive four and eight stroking, and an appreciable falling off in power. This latter item is particularly noticeable when the exhaust port becomes fouled with carbon as it causes an obstruction to the free escape of the exhaust gas, and interferes with the correct scavenging of the cylinder which is so necessary for the efficient transfer of combustible mixture from the crankcase.

The correct procedure for decarbonising is described below:—

Undo the carburetter petrol pipe union nut. Take care not to damage or lose the petrol filter and fibre washers. Slacken the clip securing the carburetter to the stub on the cylinder barrel so that it may be withdrawn and tied back out of

the way. The exhaust pipe and silencer should be removed, after unscrewing the screwed collar which holds the pipe to the barrel, with the aid of special 'C' spanner provided in the tool kit. Care must be taken not to damage or lose the copper washer. This washer is important and if damaged it must be replaced with a new one. Finally detach the high tension lead.

Removing the Cylinder Head

Remove the sparking plug, and decompressor (see below). The cylinder head is attached to the barrel by four bolts, when these are removed the head can be lifted off. If it tends to stick a sharp blow with a wooden mallet low down on the head will free it. Unless the gasket is in perfect condition it must be replaced by a new one.

Decompressor.

To remove, release the cable by undoing the bolt holding the cable under the clamp plate. Remove the whole assembly by unscrewing from the cylinder head. After a considerable mileage the valve may not seat properly causing lack of compression and consequently poor performance. As this rarely occurs before decarbonisation is due, it is advantageous to examine, and if necessary reseal the valve at the same time. The arm *A* (Fig. 8) should be held by clamping (not too tightly) in a vice so that the valve *B* can be screwed out of the arm. All traces of carbon must be scraped off the valve and body. The valve stem may be cleaned by rubbing with fine emery cloth. To grind in the valve smear a small quantity of grinding

compound over the joint, replace the valve in the decompressor body, and rotate it gently back and forth with a screwdriver.

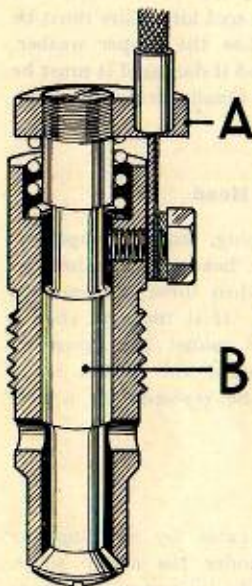

Lift the valve occasionally and rotate it to a new position. This operation should be continued until the valve and valve seat show a uniformly smooth metallic surface all round. Before re-assembly all traces of grinding compound must be removed, and the valve stem smeared with oil. The holes in the cylinder head and barrel which connect the decompressor to the exhaust port should also be cleaned, since if they are blocked the decompressor will not work.

To Decarbonise the Piston.

Rotate the engine until the piston is at the top of its stroke, and scrape off all the carbon with an old blunt screwdriver. The piston is made of aluminium and must be treated with great care or it will become scratched. Finally when all the carbon is removed wipe with a clean rag.

To Decarbonise the Head.

Scrape all traces of carbon from the combustion space bearing in mind again that the aluminium is

soft and easily damaged if the decarbonising tool is carelessly applied. Finally wipe clean to ensure the removal of all loose particles.

Removing the Cylinder Barrel.

The cylinder barrel is attached to the crankcase by means of four studs. When the nuts are unscrewed the barrel can be removed. Care must be taken when removing the barrel to support the piston as it emerges from the bottom of the bore so that it may not be damaged as it falls clear.

It is advisable to cover the mouth of the crankcase with a clean rag to prevent dust and dirt from falling into it.

The Ports.

Most of the carbon deposit likely to have accumulated in the cylinder will be in the exhaust port. Scrape this out very carefully, taking care not to let the tool slip into the bore and damage the smooth surface. Examine the transfer and inlet ports for the presence of carbon, although this is unlikely to be heavy, and finally wipe the ports and cylinder bore absolutely clean.

Piston.

Place the cylinder head and barrel on one side and examine the piston. It should not be necessary to remove this from the connecting rod, but if this should be desired for any reason, first remove the circlip from one end of the gudgeon pin using a pair of pointed nose pliers or some other suitable instrument to lever the circlip out. Then holding the piston firmly in the hand, tap the gudgeon pin out from the other end. If it is too tight to move it

can be released by warming the piston with a rag which has been soaked in hot water and wrung out. Application of this rag will cause the aluminium alloy of the piston to expand more than the steel gudgeon pin, thus releasing the latter which can then be freely pushed or tapped out.

Piston Rings.

Examine the piston rings. If they are in good condition, the rings will be found to present a uniformly smooth metallic surface over their entire periferies and in this case they should not be disturbed.

If the rings are stuck in the grooves they will need to be carefully prised free and removed from the piston. All carbon deposit should be carefully scraped from the grooves and the inside edges of the rings. If either of the rings show brown patches on the face, replace with a new ring. On current models, a spring tensioner is fitted behind the bottom scraper ring. This tensioner should be examined, and if there are any signs that it has fractured, or has lost any of its springiness, it should be replaced. In no circumstances should the tensioner be fitted behind the uppermost or compression ring. New rings should be genuine Villiers spares, or made especially to fit this engine so that they will provide the correct clearances when fitted in the bore, but if for any reason Villiers spares are not obtainable, these points must receive careful attention. First place the ring in the cylinder bore in a position where it is clear of the ports and, making certain that it is square in the bore, by pressing the skirt of the piston against it, examine the gap, which should not be less than specified (see technical data page 4). Having satisfied yourself on this point, place the ring in its groove on the piston

and make certain that it is free without perceptible up and down play. If it is not free and the groove itself is clean, rub the ring down on a piece of fine emery cloth laid on a dead flat surface, using a rotary motion of the arm to ensure uniform pressure on the ring. As soon as the ring is found to be free in its groove, wipe it absolutely clean and fit into position.

Check also that there is sufficient clearance between the inner portion of the gap and the locating peg in the groove. Do this by closing the ring in its groove by finger pressure until there is no gap, thus showing that there is clearance at the peg underneath. If the gap will not close, indicating that the steps are binding on the peg, ease the steps gently with a dead smooth file. It should be noted that piston rings are very brittle, and unless handled with care are easily broken.

Re-fitting the Piston.

When the rings are re-fitted, replace the piston on the connecting rod, smear the gudgeon pin liberally with oil and tap into position. Fit the new gudgeon pin circlip which should spring into position in its groove.

Big End Bearing.

While the piston is off it is as well to test the big end bearing for wear. This is done by taking hold of the connecting rod stem and pulling it upwards until the crank is at the top dead centre. Then holding it in this position, try gently but firmly to pull and push the connecting rod up and down in order to feel whether there is any play. If the big end is in sound condition there should be no play in this direction, although it may be possible to

rock the rod sideways, i.e., at right angles to the axis of the machine. If verticle play is perceptable in the big end, and you do not feel qualified to decide whether the amount in evidence is permissable or not, you should seek expert advice. This point is not likely to give trouble, however, provided that the machine has been carefully used and adequately lubricated. The big end bearing is of ample dimensions for the work it has to do, but if for any reason it has deteriorated as the result of neglect or abuse, it should be replaced. Unless you have the necessary experience and facilities for this class of work it is preferable to have it done by an expert repairer.

Re-assembly.

Before attempting to replace the cylinder barrel, smear the piston generously with engine oil, fit a new gasket, and then place the barrel over the piston, carefully manipulating the rings into the end of the bore. See that they enter freely without the application of force and that they are correctly located by their pegs. As soon as the cylinder barrel is home tighten down the nuts. Refit the cylinder head; if the gasket is damaged a new one must be fitted.

Tighten down the four bolts in diagonal order so as to avoid distortion.

Examine the sparking plug (see page 21) and replace if sound. The decompressor and cable can now be re-fitted, note that there should be a little play in the cable. Refit the carburetter.

Silencer.

Before refitting the exhaust pipe and silencer, they should be soaked in a strong caustic solution, preferably overnight. The carbon will then be

freed and can be washed with running water. This solution does not harm the chromium plate. Finally replace the exhaust pipe and silencer. Make sure that the copper ring forming the joint between the exhaust pipe and barrel is in good condition and properly fitted before tightening the retaining ring.

THE CARBURETTER.

Operation of the Carburetter.

Its function is to supply a correct proportion of petrol and air to the engine over a wide range of climatic, temperature and road conditions. The jet and centre piece in the Villiers carburetter are surrounded by the float chamber. The annular float rises as the fuel enters the chamber, then as the correct level is obtained the forked lever on top of the float, lifts the fuel valve needle. This has a conical end, and shuts off the fuel supply by closing the hole in the bush fitted in the carburetter body.

Dismantling.

Dismantling of the carburetter is made easier if it is removed from the machine.

The carburetter should be removed from the engine in the following order:— Slacken the petrol pipe by undoing the hexagon nut under the petrol tap. Unscrew the petrol pipe union taking care not to lose the petrol filter and fibre washers. Finally slacken the clip which secures the carburetter to the stub on the cylinder barrel, the carburetter can now be removed.

Removing the Throttle from the body.

Fully open the throttle and unscrew the slide assembly, take care not to damage the taper needle.

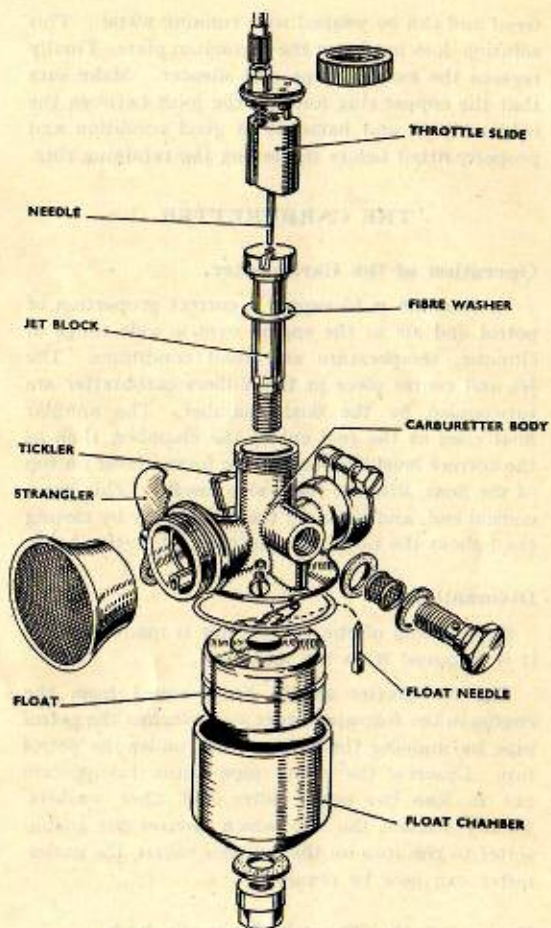

Fig. 9. The Carburetter dismantled.

Removing Jet Block and Fuel Needle.

Unscrew the bottom nut underneath the float chamber cup, do not lose the fibre washer. The cup can then be removed with the float inside. If the fibre washer between the cup and the carburetter body is loose, it should be removed to prevent damage or loss. Slacken the locking screw situated below and to the rear of the petrol pipe union. The jet block with the fibre washer under the head can then be pushed up through the throttle bore.

When the jet block is removed the float lever can swing round and allow the fuel needle to drop out of its seating. It is advisable therefore to remove the needle when the centrepiece is removed, and they should be kept in a safe place until required for re-assembly. No attempt should be made to remove the fuel needle lever from the carburetter body.

Carburetter Setting.

The carburetter is fitted with taper needle marked $2\frac{1}{2}$ on the parallel portion of the head, a jet block marked J8 on the head, and the jet (not detachable) marked 8 on the hexagon portion. The normal taper needle setting is $29/32$ " from the bottom of the throttle to the end of the needle, but to a certain extent this is matter of individual adjustment to suit each engine.

Re-assembly.

Reverse the procedure as described above, but when re-fitting the float do not overtighten the bottom nut as this may distort the jet block.

Special Note:- New riders are especially advised to study the action of the strangler, and to treat this device with respect. It should only be used

momentarily when starting from cold and even then only when necessary. Immediately the engine fires it should be opened. This point is of special importance in the event of difficult starting, probably due to some other circumstance such as a defective sparking plug, for repeated pedalling or pushing with the strangler closed results in the accumulation of liquid petrol in the crankcase, and when this occurs starting is quite impossible until it is drained away by the removal of the crankcase drain plug (see page 9).

ELECTRICAL EQUIPMENT.

The Flywheel Magneto.

This is a Villiers six pole instrument providing current for both the ignition and lighting systems. The magneto is fitted with four permanent magnets and two dummies, and should these ever be removed it is important that they are replaced in their original positions relative to the cam. The armature plate, which carries the ignition and lighting coils, and the contact breaker mechanism, is secured to the engine crankcase by four screws.

Removing the Flywheel Magneto.

This should not be attempted by the private owner unless the Villiers special hammer tight spanner is used for the centre nut. This nut is imprisoned in the flywheel and acts as an extractor when turned in an anti-clockwise direction.

On re-assembling, fit the flywheel loosely on its shaft.

Set the piston $\frac{1}{4}$ in. before Top Dead Centre, and then rotate the flywheel (without turning the crankshaft) until the contact breaker points are about to open and the timing marks on the flywheel and backplate coincide. Then tighten up the

flywheel centre nut, until flywheel taper grips the mainshaft. Check that the flywheel has not slipped, and finally tighten the centre nut with the special hammer tight spanner. Refit the cover and screws.

Contact Breaker Points.

About every 5,000 miles remove the magneto cover by unscrewing the three screws, and examine the contact breaker. If the contacts are burned or blackened, clean them with fine carborundum stone or fine emery cloth, and afterwards wipe away any dust or dirt with a petrol moistened cloth. Check the contact breaker setting after cleaning.

To check the setting, turn the engine over until the contacts are fully opened and insert the gauge provided on the ignition spanner. If the setting is correct (.012 - .015 in.) the gauge should be a sliding fit. If, however the gap varies appreciably from this setting slacken *E* (Fig. 4), and move the fixed contact plate *G* until the gap is correct. Finally tighten the screw *E*.

Lubrication.

Smear the cam lubricating pad every 5,000 miles with thick oil or grease or better still High Melting Point grease. It must be noted that if too much grease is applied it may creep along the rocker arm and get on to the contact breaker points.

The High Tension Cable.

If after considerable milage the high tension cable shows signs of cracking or perishing it must be replaced by 7 mm. rubber covered ignition cable. To make the connection to the pick-up terminal, fit the moulded terminal nut over the cable, bare the end of the cable for about $\frac{1}{4}$ in., thread the wire through the washer removed from the original cable and bend back the wire strands. Screw the nut into its terminal.

LIGHTING SET.

Headlamp.

The lamp front, together with the bulb assembly, is secured to the main lamp casing by means of a clip under the lamp. To replace a bulb or battery, therefore, it is only necessary to loosen the clip and the rim can be removed.

Rear Lamp.

A single bulb is used. The transparent red plastic portion of the lamp can be removed by slackening the screw, and pulling away from the main assembly

Note. The connector fitted to the lighting cable is covered with a rubber sleeve, it is important that this sleeve is always in position over the connector, otherwise there is a possibility of a short circuit.

Replacement Bulbs.

Headlamp (main)	6 volt	12 watt
Headlamp (parking)	...	4 volt	.3 amp.
Rear lamp	4 volt	.3 amp.

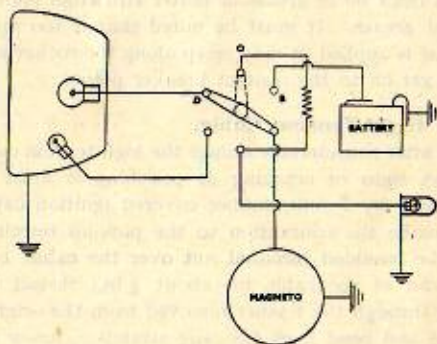

Fig. 10. The Wiring Diagram.

PROPRIETARY INSTRUMENTS FITTINGS AND ACCESSORIES

No expense is spared to secure as standard equipment the most suitable and highest quality instruments and accessories. Nevertheless, the Company's guarantee does not cover such parts, and in the event of trouble being experienced the parts in question should be returned to and claims made direct on the actual manufacturers, who will deal with them on the terms of their respective guarantees, as follows:—

Engine (including Carburetter and Generator)
The Villiers Engineering Co. Ltd., Marston Road,
Wolverhampton.

Lamps: Messrs. Joseph Lucas Ltd., B'ham 19.

Sparking Plug: Messrs. Lodge Plugs Ltd., St.
Peters Road, Rugby.

Saddle: Messrs. J. B. Brooks & Co. Ltd., Great
Charles Street, Birmingham.

Tyre: Messrs. Dunlop Rubber Co. Ltd., Fort
Dunlop, Birmingham.

SPECIAL NOTE.

Prompt attention to all claims under guarantee will be ensured if your covering letter gives:—

- (1) Make, year and model and Engine and Frame Nos.*
- (2) Date of purchase and name of dealer from whom purchased.

* *Engine number is stamped on the crankcase nearside, below cylinder barrel joint.*

Frame number is stamped on nearside rear fork-end.

