

**BATAVUS**



***The Better Moped***

SOLE IMPORTERS AND DISTRIBUTORS FOR THE U K & IRELAND

**HARGLO LIMITED**





HARGLO LIMITED  
462 Station Road,  
Dorridge,  
Solihull.

Telephone: Knowle (05645) 5835

GENERAL SERVICE NEWS NO.1

WARRANTY PROCEDURE

1. Our aim is to make the handling of warranty claims as simple and speedy as possible.
2. Our policy is to replace defective components rather than to issue credit for their cost.
3. Claims may be made in any of the following ways:-
  - (a) By telephone
  - (b) On your own letterheading
  - (c) On our own warranty claim forms - available on request.
4. All claims should state:-
  - (a) The frame number and model of the machine concerned
  - (b) Date of sale
  - (c) Mileage
  - (d) A brief description of the problem.
5. Original parts should, where possible, accompany the claim.
6. If original parts do not accompany the claim they should, unless otherwise indicated, be returned immediately you receive replacements.
7. To assist our identification of returned parts already replaced please use the tie on label, sample attached, which will in future accompany all advance replacements.
8. Do not use the label as an address label - simply tie it to the displaced part(s) and pack suitably for return post.
9. Please help us to keep down administration costs by following this simple procedure.
10. We will then be able to continue to offer you the best service in the business.

**WARRANTY PARTS RETURN**

Claim No. .... Date .....

Frame No. ....

Date of Sale .....

**ATTACH TO PART(S) FIRMLY  
DO NOT use as Address Label**

**HARGLO LIMITED,**

**462 STATION ROAD,**

**DORRIDGE, SOLIHULL,**

**WARWICKSHIRE.**

**Tel.: KNOWLE (05645) 5835**



# BATAVUS FONGERS MAGNEET

batavus intercycle b.v. / rijwiel- en motorenfabriek / heerenveen / postbus 515 / telef. 05130-39123 / telex 46026

## REPAIR TIME GUIDE

The following times are for the guidance of dealer service staff and will be used in the calculation of warranty labour allowances.

<u>ENGINE</u>	<u>Minutes</u>	
1) Remove and refit engine	60	
2) Remove and refit ignition coil - test and adjust -	45	
3) Dismantle and re-assemble clutch	30	
4) Replace crankshaft	150	
5) Replace crankshaft oil seals	45	
6) Correct overheating		
a) clean membrane	}	60
b) check oil seals		
c) replace piston rings		
7) Replace engine bracket	60	
8) Adjust ignition setting	15	
9) Replace V belt and pulley	25	
10) Renew pulley needle bearing	20	
11) Remove and replace condenser test	30	
12) Replace cylinder and piston	30	
13) Replace cylinder head	15	
14) Dismantle to decarbonize engine and re-assemble	30	
15) Dismantle to decarbonize exhaust system and re-assemble	30	
<u>CARBURETTOR</u>		
16) Replace float	5	
17) Inspect and clean; replace parts as necessary	30	
<u>LIGHTING UNIT</u>		
18) Replace headlamp complete	15	
19) Replace headlamp insert	5	
20) Replace bulb	5	
21) Replace rearlight complete	15	
22) Replace rearlight shell	5	
<u>FRAME</u>		
23) Replace frame - Model V	180	
24) Replace frame - Model VA Super	120	
25) Remove and refit front fork	60	
26) replace fork spring excluding removac and re-fitting	20	
27) Replace fork legs and crown plate	60	
28) Replace fuel tank incl. tap and draining	20	
29) Replace fuel tap incl. draining	15	
30) Replace front mudguard	20	



# BATAVUS FONGERS MAGNEET

batavus intercycle b.v. / rijwielen- en motorenfabriek / heerenveen / postbus 515 / telef. 05130-39123 / telex 46026

## - 2 - Repair time guide .

	Minutes
31) Replace rear mudguard	20
32) Remove and replace rear carrier	15
34) Remove and refit rear fork	90
35) Replace pedal crank axle	25
36) Remove and refit centre stand	20

Warranty labour at the rate of £ 1.60 per hour will be allowed on all warranty jobs on which the scheduled time allowance is 15 minutes or more. No labour allowance will be made in respect of accident repairs, normal wear and tear or routine service.

Heerenveen, August 1973.

# NEWS FLASHERS

By HARGLO/CEV

## MOPED AND LIGHT MOTOR CYCLE TURN SIGNALS

Shipments arriving regularly but selling as they land.

Fit Batavus and all other well-known makes.

Battery automatically re-charged by lighting coils of standard generator.

Full fitting instructions with each kit.

Improve rider safety and your profits.

Not to be confused with cheap "torch battery" sets.

£22.75 PLUS VAT,  
DIS. 25 PER CENT

---

TO: Harglo Limited, 462 Station Road, Dorridge, Solihull.

Please supply as soon as possible:-

HA 9008

Turn signal kits

.....  
(Quantity)

Dealer

Name .....

Address .....

.....

.....

Signed .....

Dated .....



BATAVUS SERVICE NEWS NO. 9

The clutch of the M48 engine has been modified in various respects in order to:

- improve acceleration
- increase the life of the clutch-housing
- avoid failure to disengage
- avoid that the needle bearing runs dry.

The following parts have been changed and/or modified:

- a. The clutch-housing (1) has been modified in such a way that the gear ratio is reduced slightly. The centre of the new housing is wider and new hardened steel washers (15 x 28 x 0.5 mm) are introduced to eliminate wear on the housing centre and back face of the clutch hub. The new housing is red-brown in colour.
- b. A new hardened steel washer (12 x 24 x 0.5 mm) (4) is introduced to obtain more space between the clutch hub (5) and the clutch-housing (1).
- c. The clutchspring (6) has been shortened to increase the number of revolutions at which the clutch begins to operate. The shortened spring is marked in red. In the event of insufficient acceleration or clutch disengagement it is advised to replace the clutch spring (6). At the same time the clearance of the clutch plate unit has to be checked. Should this clearance be less than 0.5 mm a new 3.6 mm thick friction plate (8) has to be fitted.
- d. The friction plate (8) has been reduced in thickness from 3.8 mm to 3.6 mm and the recommended clearance between the clutch endplate and friction plate (with a nil clearance between friction and pressure plate) is now 0.5 - 1.0 mm.
- e. The pressure plate (7) has been hardened. This hardened pressure plate can be recognized by its red-grey colour.
- f. Off the middle of 1976 the needlebearing (B) fitted to the engine will be provided with a seal. In the event of replacement of the old needlebearing it is important that the new bearing is fitted with the seal facing the engine. At the same time all M48 engines will be equipped with a feltring instead of the existing oilseal (A).

As the above mentioned/modifications are not applicable to all M48 engine models it is necessary to use the subjoined list of changes.

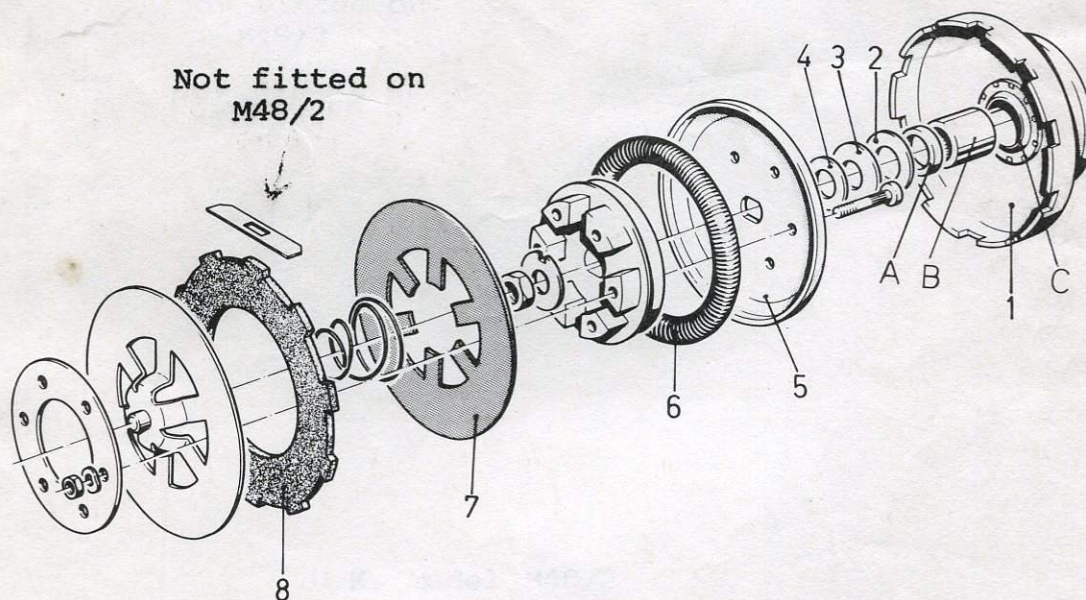

**U.K. Model M48/2**

<p>Nr. 1 Clutch housing Gear Ratio</p> <p>Nr. 6 Colour</p> <p>Nr. B Needle bearing Feltring</p> <p>Nr. 2 Washer 15 x 28 x 0,5</p> <p>Nr. 4 Washer 12 x 24 x 0,5</p> <p>Nr. 7 Pressure Plate</p> <p>Nr. 6 Clutch Spring</p> <p>Nr. 8 Friction Plate</p>	<p>M48-01 (40km/h); M48-08 (45km/h) M48-02 (50km/h)</p> <p>amended (partnumber: 48-08-80)</p> <p>amended</p> <p>red-brown</p> <p>amended (partnumber: 81-30-84)</p> <p>new (partnumber: 48-08-95)</p> <p>new (partnumber: 48-08-99)</p> <p>new (partnumber: 48-08-14)</p> <p>amended (partnumber: 54-08-98)</p> <p>amended (partnumber: 48-08-86)</p> <p>amended (partnumber: 48-08-89)</p>	<p>M48-10(20km/h); M48-05 (25 km/h) M48-04 (30 km/h)</p> <p>amended (partnumber: 48-08-94)</p> <p>unchanged</p> <p>yellow or green</p> <p>amended (partnumber: 81-30-84)</p> <p>new (partnumber: 48-08-95)</p> <p>new (partnumber: 48-08-99)</p> <p>not applicable</p> <p>unchanged (partnumber: 48-08-88)</p> <p>amended (partnumber: 48-08-86)</p> <p>amended (partnumber: 48-08-89)</p>
--	---	--

24-103-01 CRANK WITH CHAIN WHEEL C.122 481093 FRONT SPROCKET C.123

42-138 Speed Drive C.118 REAR LAMP LENS DEALER KIT (BASIC) 41-244-10 CHOKE LEVER C.119

Part number REAR WHEEL SPROCKET C.123 \$13086 TIGHT NEEDLE BEARING C.123 PCS. REAR WHEEL SPKES C.118

Part number	Description	Qty	Price	Code
481784	Inlet Gasket	10	0.05	C.112
481783	Membrane Cpte	1	1.08	C.124
816180	Oil seal	1	0.36	C.122
45-196-02	Cover	1	0.60	C.112
816181	Seal	2	0.67	C.122
480282	Cover Spring	10	0.05	C.112
480682	Cyl. base gasket	10	0.07	C.112
480502	Piston ring	2	0.40	C.125
841520	C/P circlip	6	0.05	C.125
481732	Air filter	2	0.79	C.124
481733	Rubber ring	1	0.12	C.124
481713	Air silencer	1	0.93	C.124
481735	Air silencer clip	3	0.20	C.124
481736	Float	1	0.75	C.124
481737	gasket	3	0.06	C.112
481741	Filter	1	0.21	C.124
481740	Banjo	1	0.43	C.124
481742	Banjo bolt	1	0.35	C.124
480891	V belt	1	2.17	C.123
480882	End plate	1	0.81	C.123
480889	clutch plate	2	1.30	C.123
816480	Gas and oil seal	1	0.75	C.122
41-250	F/B/ Cable	2	0.92	C.118
41-249	R/B/ Cable	2	1.03	C.118
41-248	Throttle cable	2	0.78	C.118
41-247	Starter cable	2	0.60	C.118
41-246	Choke cable	2	0.51	C.118
481826	C/B/ points set	1	1.60	C.121
481830	Condenser	1	0.96	C.121
481825	M.T. Coil	1	5.50	C.121
49-124-011	chainwheel	1	0.20	C.120
44-405	Spring	1	0.20	C.120
44-048	tank cap	1	0.51	T.48
45-009	Chain stretcher	1	0.20	C.120
46-051	fastening clip	1	0.15	62P C.119
46-287	Clip housing	1	0.30	
06-011	Spring washer	2	0.01	
02-003	nut	2	0.02	
41-245-06	L/H Brake lever	1	1.03	C.119
41-245-07	Start lever	1	0.75	C.119
41-244-06	R/H Brake lever	1	1.03	C.119
40-089-03	Axle nut	4	0.10	T.40
40-089-04	Axle cone	2	0.47	T.67
40-089-06	Axle cup	2	0.47	C.113
40-089-07	Brake shoes,pr.	1	1.53	T.65
40-089-10	Brake cam	1	0.87	C.113
40-089-11	Brake lever	1	0.39	C.113
40-091-02	Axle nut	4	0.10	T.82
40-091-04	Dust ring	2	0.17	C.113
40-091-05	Axle cup	2	0.47	C.113
40-091-07	Brake cam	1	0.87	C.113
40-091-08	Brake shoes,pr.	1	1.53	T.65 C.113
40-091-09	Spring	2	0.10	T.65 C.113
40-091-10	Brake lever	1	0.39	C.113
46-141	Exhaust gasket	4	0.10	C.112
40-091-03	Axle cone	2	0.47	T.49

FRYWHEEL ASSY INC COMP 210-00 (C.125) SPEED HEAD C.112 NIGHTS SWITCH C.121 1.30 + VINT  
 CYL BARREL & PISTON COMP 213-50 (C.112) 40-098 FREEWHEEL EX 3/16 20T. 2.45 + VINT  
 PISTONS COMP STD RIST O/S 2-3-95 (C.125) 42-137 SPEED CABLE C.118 R.123

# BATAVUS

H A R G L O - K I T

Designed to complement BATAVUS The Better Moped

\* Trade Discount 34% for payments received within 21 days from date of Invoice, otherwise 25% net monthly.

\* Orders over £35.00 trade, carriage free.

\* Orders under £25.00 trade, subject to surcharge of 60p.

TO: HARGLO LIMITED, 462 Station Road, Dorridge, Solihull.

Please supply:-

<u>Part No.</u>	<u>DESCRIPTION</u>	<u>MODELS</u>	<u>RECOMMENDED RETAIL PRICE</u>	<u>QUANTITY</u>
HA 9001	Legshield Assy.	Go-Go's, HS50	£ 10.50	.....
HA 9002	Windscreen Assy.	All	10.50	.....
HA 9003	Pannier set	Starglo, Go-Gos, HS50	10.50	.....
HA 9004	Rear Carrier	HS50	5.50	.....
HA 9005	Legshield	Compact	10.50	.....
HA 9007	Pannier set	Compact	10.50	.....
HA 9009	Legshield	Starglo	10.50	.....
13-096	Rear carrier clip	Go-Go	0.95	.....
13-100	Rear carrier	MK4S	9.50	.....
49-034	Front carrier	Starglo, Go-Gos, HS50	4.00	.....
49-035	Front basket	All except MK4S	3.50	.....
49-090	Front carrier	Compact	4.00	.....
87-050	Mirror assembly	All	2.95	.....

Plus TYRES AND TUBES on the same terms

48-124	Tyre 2.00 x 20	Starglo, Go-Gos, HS50, Bronco front	3.95	.....
48-133	Tube 2.00 x 20	As above	1.75	.....
48-154	Tube 2.25 x 20	Bronco rear	1.75	.....
48-155	Tyre 2.25 x 20	Bronco rear	4.50	.....
48-066	Tyre 2.75 x 17	MK4S	9.95	.....
48-067	Tube 2.75 x 17	MK4S	3.50	.....
48-091	Tyre 2.50 x 17	MK4S	9.75	.....
48-092	Tube 2.50 x 17	MK4S	3.50	.....
48-137	Tyre 3.00 x 10	Compact	9.50	.....
48-138	Tube 3.00 x 10	Compact	2.95	.....

All previous issues withdrawn

-

October 1976

Dealer .....

Address .....

.....

.....

Date .....

# BATAVUS

September 1976

## HARGLO-KIT ORDER

Please supply:-

1. THE BOOK OF BATAVUS -  
(Detailed Workshop Manual)

A refreshing new approach  
to service literature.

Retail price ~~£1.50~~  
Discount 34% (21 days)

..... copies of  
The Book of Batavus.

2. WATERPROOF LIGHTWEIGHT TWO-PIECE  
RIDER'S SUITS

British made.  
Bermuda blue.  
Four sizes.

Retail Price ~~£14.95~~  
Discount 34% (21 days)

Rider's Suits:

Small/Small .....

Small .....

Medium .....

Large .....

3. HARGLO-CEV MOPED AND LIGHTWEIGHT  
TURN SIGNAL KITS

Fit all leading makes.  
Simple to fit.  
No battery filling.  
Dry nickel cadmium battery charged  
automatically by generator.

Retail price ~~£22.75~~  
Discount 25%

..... HARGLO-CEV  
TURN SIGNAL KITS

POST FREE and an extra  
free Book of Batavus  
on orders for a minimum  
of :-

5 Books of Batavus +

3 Rider's Suits +

2 Turn Signal Kits.

TO: HARGLO LIMITED,  
462 Station Road,  
Dorridge,  
Solihull, B93 8HB

From:-

Name .....

Address .....

Date .....

*See Batavus*

*Kit Book  
For Prices.*

*(with other  
accessory  
Books  
on shelf)*

# BATAVUS

HARGLO LIMITED, 462 Station Road, Dorridge, Solihull. Tel: 05645 5835

## PARTS PRICE LIST - APRIL 1977

Part No.	Description	Retail	Part No.	Description	Retail
00-006	Bolt (per 10)	0.70	06-014	Lockring (per 10)	0.60
00-007	Bolt " "	0.70	06-021	Cap nut " "	0.65
00-008	Bolt " "	0.90	06-023	Lockring	0.15
00-009	Bolt " "	0.90	06-032	Lockring (per 10)	0.35
00-010	Bolt	0.15	06-055	Lockring " "	1.10
00-015	Bolt (per 10)	0.80	06-065	Nylon ring " "	0.50
00-024	Bolt " "	0.90	06-083	Lockring " "	0.40
00-025	Bolt	0.15	06-085	Washer	0.15
00-029	Bolt	0.15	06-088	Lockring (per 10)	0.25
00-030	Bolt	0.15	06-089	Washer " "	0.70
00-032	Bolt	0.15	07-018	Cage nut " "	0.60
00-040	Bolt (per 10)	0.50	07-023	Speed nut " "	0.20
00-046	Bolt " "	0.55	08-001	Cotter	0.35
00-063	Bolt	0.15	08-017	Cotter	Use 08-001
00-080	Bolt	0.20	10-245	Strip	0.55
00-094	Bolt	0.20	10-246	Strip	0.55
00-121	Bolt	2.25	10-251	Strip	0.35
00-133	Stand bolt	0.25	10-342	E/Bracket	10.00
00-142	Bolt	0.20	10-342-01	L/H E/plate	1.95
00-143	Bolt (per 10)	0.90	10-342-02	R/H E/plate	2.00
00-144	Bolt	0.45	10-342-03	E/Support cradle	3.50
00-146	Bolt	0.15	10-344	Exhaust brkt assy	3.50
00-147	Bolt	0.15	10-344-01	Exhaust bracket	1.40
00-149	Bolt	0.30	10-349	No. plate bracket	0.85
02-003	Nut (per 10)	0.35	10-353	Exhaust brkt assy	3.75
02-004	Nut	Use 02-078	10-353-01	Exhaust bracket	1.50
02-005	Nut	Use 02-078	10-358	E/Support brkt	12.50
02-012	Nut	0.20	10-358-01	L/H E/plate	2.75
02-014	Nut	0.15	10-358-02	R/H E/plate	2.90
02-021	Cap nut (per 10)	0.60	10-358-03	Engine cradle	3.80
02-033	Bolt " "	0.40	10-369	Seat support	2.50
02-038	Nut " "	0.50	10-375	Strip	2.00
02-057	Nut " "	0.80	10-389	Exhaust brkt assy	3.50
02-059	Ball head nut	0.70	10-390	R/mudguard plate	0.90
02-070	Nut (per 10)	0.75	12-009	Handlebar	4.75
02-075	Nut (castellated)	2.75	12-186	Stabiliser	2.60
02-077	Nut (per 10)	0.60	12-194	Handlebar	4.75
02-078	Nut " "	0.60	12-230	Handlebar	6.25
02-085	Nut	0.60	12-267	Handlebar	4.75
03-020	Nut	1.70	12-272	Handlebar	5.95
04-002	Stud	0.10	13-093	Carrier	6.80
04-003	Stud	0.15	14-066	L/H pedal crank	2.95
04-009	Stud	0.15	14-067	R/H pedal crank	2.95
04-010	Stud	0.20	14-073	L/H pedal crank	2.95
06-002	Lockring (per 10)	0.35	14-074	R/H pedal crank	2.95
06-003	Lockring " "	0.45	14-079	Bearing	1.10
06-004	Lockring " "	0.35	14-088	R/H Crank	9.50
06-005	Lockring " "	0.40	16-097	Silencer assy	11.50
06-009	Washer " "	0.25	16-097-01	Silencer inner	1.65
06-010	Spring disc " "	0.25	16-097-02	Silencer rear	2.75
06-011	S/Washer " "	0.25	16-097-03	Silencer body. Not supplied	
06-013	S/disc " "	0.25	16-098	Exhaust pipe	4.95

BATAVUS MOPEDS

<u>Part No.</u>	<u>Description</u>	<u>Retail</u>	<u>Part No.</u>	<u>Description</u>	<u>Retail</u>
16-100	Silencer clip	0.75	40-167	Spokes	0.12
16-111	Exhaust pipe	5.30	40-168	Rim	Use 40-206
16-113	Exht shield clamp	0.60	40-171	Spokes	0.08
16-114	Exhaust pipe	5.30	40-172	Spokes	0.08
16-116	Silencer assy	11.50	40-173	Spokes	0.08
16-116-03	Silencer body. Not supp'd		40-178	Rim	6.95
16-118	Exhaust pipe	5.30	40-180	Spokes	0.08
16-119	Silencer	16.50	40-182	Spokes	0.08
16-119-01	Baffle	2.00	40-184	Spokes	0.08
16-119-02	Silencer end	3.50	40-193	Spokes	0.08
16-119-03	Silencer body Not supp'd		40-206	Rim	6.50
17-030	L/H Fr. fender	3.60	40-207	Rim (28 hole)	6.50
17-031	R/H Fr. fender	3.60	40-209	Spokes	0.08
17-032	Carrier fender	2.75	40-210	Spokes	0.08
17-033	Headlamp fender	1.60	41-117	Cable nippleholder	0.20
24-073	Lockring (per 10)	0.80	41-175	Plastic grip	0.40
24-103-01	Bracket axle	4.95	41-179	Harness plug	0.75
30-137	R/Mudguard stay	1.20	41-186	Twistgrip assy	12.95
30-183	Fr/Mudguard stay	1.20	41-186/A	Rubber	0.95
30-184	Rear mudguard	5.50	41-186-01	Bolt	0.18
30-193	R/Mudguard Durolon	4.75	41-186-05	Bolt	0.40
30-193	R/Mudguard S/S	5.50	41-186-06	Lever	3.75
30-197	R/mudguard	5.50	41-188	Fixed grip	0.95
30-198	F/Mudguard stay	1.20	41-204	Decom. lever	1.60
30-221-02	F/Mudguard S/S	6.30	41-207	Cable adjuster	0.50
30-222	R/Mudguard S/S. Use 30-193		41-208	Adjuster	0.60
30-224	Rear mudguard	10.80	41-244	Twistgrip assy	5.25
30-228	Front stay	6.00	41-244-01	Bolt	0.15
30-234	F/mudguard stay	1.20	41-244-02	Lever clamp	3.50
30-235	R/mudguard	5.50	41-244-03	Nut	0.05
30-238	Fr/mudguard	5.50	41-244-04	Washer	0.04
30-239	Fr/mudguard	4.25	41-244-05	Bolt	0.15
30-242	Fr/mudguard	7.70	41-244-06	R/H brake lever	1.60
31-182	Chainguard	1.10	41-244-07	Throttle handle	1.90
31-185	E/cover shield	6.60	41-244-08	R/H plastic grip	0.40
31-185-01	E/cover shield. Use 31-185		41-244-10	Choke lever	0.95
31-202	Plastic extension	2.00	41-245	Brake & start lever assembly	5.25
31-206	R/H Toolbox	10.40	41-245-01	Bolt	0.15
31-207-04	L/H Toolbox cover	4.75	41-245-02	Clamping bracket	3.50
31-209-01	L/H cover shield	3.50	41-245-03	Nut	0.05
31-210-02	R/H cover shield	3.50	41-245-04	Washer	0.04
31-212-04	R/H toolbox cover	4.75	41-245-05	Bolt	0.15
31-217	Exhaust shield	6.20	41-245-06	L/H brake lever	1.60
31-218	Cover shield	6.95	41-245-07	Start lever	0.95
31-220	Central panel	8.50	41-245-08	Bolt	0.25
31-226	L/H Toolbox	10.40	41-245-09	Bolt	0.15
31-229	Chainguard	7.20	41-246	Choke cable	0.85
33-038-01	Fuel tank	18.50	41-247	Start cable	0.95
33-039	Fuel tank	15.25	41-248	Throttle cable	1.25
33-040-01	*Fuel tank	30.50	41-249	R/brake cable	1.95
33-042-01	Fuel tank	19.50	41-250	F/brake cable	1.75
33-043	Fuel tank	17.95	41-269	Clutch cable	1.95
For 40-089 and 40-091 assemblies see 44-229 and 44-230			41-284	Harness plug	Use 41-179
40-093	Grease nipple	0.20	41-289	R/brake cable	1.95
40-098	Freewheel	Use 49-019	41-296	Horn	Use 41-413
40-130	Grease nipple	0.15	41-330	Clutch lever assy	6.95
40-144	Rim	7.50	41-393	F/brake cable	1.95
40-146	Spokes	Use 40-173	41-396	Decomp cable	1.95
			41-400	Throttle cable	1.95

BATAVUS MOPEDS

<u>Part No.</u>	<u>Description</u>	<u>Retail</u>	<u>Part No.</u>	<u>Description</u>	<u>Retail</u>
41-401	Choke cable	1.25	42-285	Switch	3.00
41-404	Start cable	1.25	42-286	Tail lamp	8.50
41-405	Throttle cable Use 41-248		42-286-01	Reflector	4.25
41-406	Choke cable Use 41-246		44-005	Footrest	3.00
41-407	F/brake cable Use 41-250		44-016	Spring	0.20
41-408	R/brake cable Use 41-249		44-018	Tank cap	1.10
41-409	Start cable Use 41-247		44-021-01	Pedal	1.20
41-410	F/brake cable	2.30	44-021-02	Pedal	1.20
41-411	R/brake cable	2.40	44-050	Tank cap	2.50
41-413	Horn	2.75	44-113	L/H Crank	2.95
41-414	Horn Use 41-296		44-229	Front hub	11.50
41-417	Throttle cable	2.75	44-229-01	Hub shell Not supplied	
42-039	Speedo	6.95	44-229-02	Spindle assy	2.95
42-060	Speedo cable	1.70	44-229-03	Nut	0.20
42-078	Bulb Use 42-082		44-229-04	Cone	0.60
42-080	Switch " 42-254		44-229-05	Dust ring	0.25
42-082	Bulb	0.35	44-229-06	Cup	0.60
42-130	Switch and cable	4.25	44-229-07	Brake shoe pair	2.60
42-137	Speedo cable	1.70	44-229-08	Brake plate	1.50
42-138	Speedo drive	2.70	44-229-09	Spring	0.18
42-173	Cable cover		44-229-10	Cam	1.10
	(per meter)	0.15	44-229-11	Lever	0.55
42-179	Plug assy Use 41-179		44-230	R/wheel hub assy.	15.50
	For 42-180 series use 42-252		44-230-01	R/hub shell Not supplied	
42-192	Speedo cable	2.15	44-230-02	Rear spindle assy	3.25
42-212	Mounting cup cmpte	6.50	44-230-03	Nut	0.20
42-214	Speedo drive	3.80	44-230-04	Cone	0.60
42-232	Horn	2.75	44-230-05	Dust ring	0.25
42-237	Fuse	0.65	44-230-06	Cup	0.60
42-238	Rear lamp	2.95	44-230-07	Brake shoe assy	2.40
42-238-01	Reflector	1.10	44-230-08	Brake plate	3.00
42-238-02	R/lamp housing. Not supp'd		44-230-09	Spring	0.18
42-239	Speedo	6.95	44-230-10	Cam	1.10
42-241 *	Tachometer	28.00	44-230-11	Lever	0.55
42-245	Headlamp cmpte	18.00	44-230-12	Bolt and nut	0.20
42-245-01	Headlamp shell	9.95	44-251	Seat pillar	1.35
42-245-02	Headlamp rim	4.25	44-277	Seat pillar	1.35
42-245-04	Light unit	9.95	44-315	Petrol pipe Use 46-315	
42-245-18	Springs (set)	1.00	44-338	Fuel tap	3.15
42-248	Cable cover Use 42-173		44-341	Spring	0.35
42-251	Headlamp bulb	0.65	44-342	Petrol tap	2.25
42-252	Headlamp assy	7.50	44-346	Chainwheel 46T	3.95
42-252-01	Headlamp shell	3.30	44-376	Clip	0.12
42-252-04	Headlamp insert	4.75	44-379	Chainwheel 50T	
42-252-05	Clip	0.20		(special order)	4.25
42-252-09	Not supplied		44-382-01	R/H Pedal Use 44-021-01	
42-252-13	Headlamp fitting	1.70	44-382-02	L/H Pedal Use 44-021-02	
42-252-14	Spring	0.15	44-393	Front hub assy	22.00
42-254	Switch	2.20	44-393-01	Front hub shell. Not supplied	
42-259	Speedo drive	3.15	44-393-02	Spindle assy	2.50
42-272	Flasher unit	3.25	44-393-07	Brake shoes (pr)	3.50
42-273	Turn signal lamp	5.25	44-393-08	Brake plate	2.80
42-275	Turn signal bulb	0.85	44-393-09	Brake spring	0.35
42-276	Rectifier	6.50	44-393-10	Brake cam	1.10
42-281	Bulb 6v 18/18w	0.75	44-393-11	Brake lever	0.75
42-282	Speedometer	7.25	44-393-16	Bearing	2.50
42-283	Battery	POA	44-400	Rear suspension	6.75
42-284	Switch	6.00	44-404	Chainwheel	3.95
			44-405	Spring	0.35

BATAVUS MOPEDS

<u>Part No.</u>	<u>Description</u>	<u>Retail</u>	<u>Part No.</u>	<u>Description</u>	<u>Retail</u>
44-406	Fuel tap	2.25	46-221	Silent bloc	0.70
44-408-02	Spindle assy	2.40	46-222	Rubber buffer	0.10
44-408-07	Brake shoes (pr)	3.75	46-223	Rubber sleeve	0.55
44-408-09	Brake spring	0.25	46-236	Carb rubber seal	0.15
44-408-10	Brake cam	1.10	46-243	Mud flap	0.70
44-408-11	Brake lever	0.95	46-264	Silent block	0.75
44-408-16	Bearing	2.50	46-279	Dust protector	0.55
44-408-17	Bearing	4.00	46-285	Distance bush	0.25
44-414	Rear suspension	18.00	46-287	Clip housing	0.40
44-425	Headlock assy	3.50	46-298	Rubber ring	0.10
44-427)	Lock set	8.50	46-306	Plastic ring	0.15
44-483)			46-309	Spacer tube	0.30
44-441	Fork spring assy	2.20	46-310	Spacer tube	0.20
44-445	Rear hub assy	13.50	46-313	Rubbers	0.25
	(28 hole)		46-314	Rubber ring	0.10
44-445-01	Rear hub shell. Not supp'd		46-315	Rubber tube, per meter	0.80
44-445-02	Rear spindle assy	3.25	46-317	Plastic mat	0.80
44-446	Front hub assy	11.50	46-321-01	Spacer tube	0.65
44-446-01	Front hub shell	28 hole Not supp'd	46-322	Rubber seal	0.40
			46-323	Rubber sleeve	0.40
44-446-02	Spindle assy	2.95	46-324	Bearing plate	1.20
44-453	Chainwheel 36T	3.95	46-329	L/H Plastic mat	0.40
44-457	Rear suspension unit	7.80	46-330	R/H Plastic mat	0.40
44-473	Spring	1.95	46-331	Spacer tube	0.25
44-473-01	Plug (screw)	0.60	46-333	Rubber sleeve	0.20
44-478	Dual seat MK4S	22.00	46-335	Bearing	1.50
44-499	Chainwheel 48T	4.20	46-344	Mudflap	3.15
44-504	Petrol tap	2.95	46-346	Instrument bracket	3.00
44-505	Dual seat	21.00	46-352	Rubber dust ring	2.35
44-510	Rear hub assy	32.50	46-353	Shaft seal	1.20
44-510-08	Brake plate	3.30	46-362	Rubber seal	0.40
44-511	Chainwheel	3.95	46-373	Silentbloc	2.90
45-009	Chain adjuster. Use 45-086		46-376	Spring clip	0.15
45-036	Pedal Chain 84L	2.40	46-378	Mats	1.10
45-066	Pedal Chain 82L	2.40	46-382	Spacer tube	0.50
45-066A	Pedal Chain link	0.30	46-387	Turn signal brkt	
45-075	Engine chain 92L	4.95		front	2.50
45-086	Chain adjuster	0.30	46-392	Engine bracket	4.40
45-109	Exhaust gasket	0.20	46-393	Turn signal brkt,	
45-134	Chain	5.95		rear	3.20
45-167	Engine chain 82L	4.25	47-003	Balls (per 100)	0.80
45-174	Engine chain 88L	4.25	47-016	Balls (per 100)	0.95
45-174A	E/chain link	0.35	47-017	Ball head set	3.95
45-175	Pedal chain 80L	2.20	47-017-01	Cone	0.70
45-196	Cover	1.40	47-017-02	Cup	0.70
46-001	Rubber buffer	0.15	47-017-03	Cup	0.70
46-021	Rubber ring	0.10	47-017-04	Cone	0.50
46-028	Rubber	0.35	47-043	Ball head set	2.50
46-029	Rubber sleeve	0.20	47-043-01	Cone	0.50
46-050	Rubber ring	0.10	47-043-02	Bearing shell	0.70
46-117	Star ring	0.25	47-043-03	Bearing shell	0.70
46-141	Exhaust gasket	0.20	47-043-04	Adjuster cone	0.70
46-158	Dust bellows	0.35	47-065	Crown plate	1.50
46-162	Rubber buffer	0.20	47-093	Ring	0.25
46-174	Bolt holder	0.30	47-097-107	Expander	1.20
46-179	Cable grommet	0.15	47-114	Steering head set	4.25
46-197	Bush	0.38	47-115	Balls (per 100)	1.00
46-201	Rubber ring. Use 46-021		47-119	Crown plate Use 47-065	
46-206	Handlebar clamp set	2.75	48-116	Rim band (Go-Go)	0.35
46-208	Flashing strip	3.30	48-139	Rim band (Compact)	0.45



BATAVUS MOPEDS

<u>Part No.</u>	<u>Description</u>	<u>Retail</u>	<u>Part No.</u>	<u>Description</u>	<u>Retail</u>
49-019	Freewheel	2.10	480183	Grommet	0.15
49-020	Freewheel	2.10	480282	Cover spring (per 20)	1.95
49-124	Auto chain tensioner	1.60	480325	Little end bush	0.55
49-124-01	Chainwheel	0.40	480381	* Crankshaft	21.50
54-071	Seat Go-Go	9.25	480501	Gudgeon pin	2.00
54-071-01	Plate	0.30	480502	Piston ring Std	0.95
54-086	Seat Compact	13.50	480511	Piston ring 1st O/S	1.20
54-088	Seat Bronco	14.50	480512	Piston ring 2nd O/S	1.20
56-012	*Rear fork	15.00	480580	Piston complete Std	9.75
56-017	Centre stand	5.60	480581	Piston cmpte 1st O/S	9.75
56-053	Footbrake lever	8.20	480582	Piston cmpte 2nd O/S	9.75
56-087	Stand Use 56-137		480682	Cylinder base gasket	0.15
56-132	*Rear fork	18.00	480683	Exhaust gasket Use 46-141	
56-135	*Front wheel assy	18.50	480690	Cylinder	19.75
56-136	*Rear wheel assy	21.00	480880	Clutch housing	
56-137	Centre stand	4.00		c/w bearing	6.95
56-141	*Frame V	35.00	480881	Clutch hub cmpte	3.50
56-165	*Front wheel assy	32.50	480882	Endplate	1.10
56-211	*Frame VA	32.50	480883	Pressure spring	0.15
56-224	Front fork assy	27.50	480886	Clutch spring	2.00
56-224-01	RH Fork leg	4.20	480887	Saucer spring	0.25
56-224-02	L/H Fork leg	4.30	480888	Pressure plate	0.95
56-224-03	Fork legs c/w crown plate	10.50	480889	Friction plate	2.50
56-224-04	Stabiliser	0.95	480890	Locking plate	0.50
56-264	Front fork assy	35.00	480891	V Belt	3.50
56-264-01	Fork top c/w crown plate	12.50	480980	Starter leaf spring	1.25
56-264-02	Crown plate	2.75	480981	Support plate	0.35
56-264-04	L/H Slider	6.00	481092	Sprocket 12T	1.85
56-264-05	R/H Slider	6.00	481093	Sprocket 13T	1.85
56-264-06	L/H Headlamp brkt	2.95	481505	Tab nut	1.50
56-264-07	R/H Hd lamp brkt	2.95	481590	* Pulley 12T	12.50
56-264-10	Stabiliser	1.80	481591	Cover	0.25
56-265	*Front wheel	19.00	481598	* Pulley 13T	12.50
56-331	*Fork assy	75.00	481713	Intake silencer	1.75
56-331-01	Fork yoke bottom	8.50	481721	Screw top	1.00
56-331-02	Fork yoke top	7.65	481722	Valve spring	0.30
56-331-04	Fork leg	15.00	481724	Clamp screw	0.18
56-331-05	Fork leg	15.00	481731	Jet holder	1.20
56-331-06	Headlamp brkt	3.40	481732	Air filter	1.75
56-331-08	Fork tube & spring	13.50	481733	Rubber ring	0.25
56-331-16	Fork clamp	2.10	481735	Silencer clip	0.40
56-341	*Frame (Compact)	31.50	481736	Float	1.75
56-381	*Frame (MK4S)	55.00	481737	Cover gasket	0.12
56-386-01	*Rear wheel assy	42.50	481738	Float chamber cover	2.00
56-414	Front fork assy. Use 56-224		481739	Screw	0.12
56-414-03	Fork legs c/w crown plate. Use 56-224-03		481740	Banjo	0.65
56-421	*Frame (Bronco)	35.00	481741	Filter	0.35
56-441	*Frame (HS50)	38.00	481742	Banjo bolt	0.70
56-452	*Fork (rear)	20.00	481743	Choke valve	0.45
56-456	*Rear wheel assy	22.00	481744	Spring	0.35
86-006	Toolbox	1.50	481746	Adjusting screw	0.35
86-006A	Toolkit	1.50	481747	Spring	0.18
			481751	Adjusting nipple	0.45
			481752	Tab nut	0.25
			481783	Membrane	2.20
			481784	Inlet gasket	0.10
			481785	Induction pipe	1.15
			481786	Shield	0.60
			481789	Carburettor	17.50
			481793	Intake tube	0.30
<u>ENGINE PARTS</u>					
HA 0008	Throttle slide	1.10			
480125	Gasket set	0.95			
480180	Crankcase Use 485180				
480181	Gasket	0.15			
480182	Grommet	0.20			

BATAVUS MOPEDS

<u>Part No.</u>	<u>Description</u>	<u>Retail</u>
481797	Washer	0.08
481821	Stator	POA
481822	Rotor	POA
481825	H.T. Coil	8.95
481826	Contact set	2.15
481929	Lighting Coil	6.50
481829/A	" " small	3.00
481830	Condenser	2.50
481887	Spark plug W240T1	0.70
481887/A	" " W260T1	0.70
481890	Suppressor	1.50
485180	Crankcase	19.50
485695	Cylinder head	8.50
810081	Ball bearing	2.95
813081	Needle bearing	2.50
813086	Needle bearing	1.95
816180	Oil seal	0.75
816181	Oil seal	1.20
816480	Gas & Oil seal	1.40
820500	Bolt	0.07
820502	Bolt	0.08
820520	Bolt	0.10
820603	Bolt	0.10
820700	Bolt	0.12
820701	Bolt	0.12
823400	Screw	0.05
823506	Crank case screw	0.12
827500	Nut	0.05
827600	Nut	0.05
827700	Nut	0.05
828000	Flywheel nut	0.20
828010	Locknut:	0.12
829680	Cylinder stud	0.45
830000	Flywheel key	0.12
840010	Tab washer	0.08
841512	Circlip	0.25
841520	Circlip	0.08
843500	Washer	0.05
843600	Washer	0.05
846600	Spring Waaher	0.05
847600	Washer	0.05
848011	Washer	0.04
No. 58	Jet	0.60
No. 56	Jet	0.60

DECALS (STICKERS)

72-807	Go-Go Tank (R/H)	0.80
72-808	Go-Go Tank (L/H)	0.80
72-933	HS50 Tank (R/H)	0.75
72-934	HS50 Tank (L/H)	0.75
72-955	Cover shield (R/H)	0.60
72-956	Cover shield (L/H)	0.60
72-966	Fuel tap	0.20
72-995	MK4S Tank (L/H)	0.80
72-996	MK4S Tank (R/H)	0.80
72-1005	Bronco Tank (R/H)	0.75
72-1006	Bronco Tank (L/H)	0.75
72-1018	MK4S Sidecover (L/H)	0.80
72-1019	MK4S Sidecover (R/H)	0.80

<u>Part No.</u>	<u>Description</u>	<u>Retail</u>
<u>Decals continued.</u>		
72-1031	HS50 Sidepanel (R/H)	0.75
72-1032	HS50 Sidepanel (L/H)	0.75
	Go-Go 2 Tank (R/H)	0.75
	Go-Go 2 Tank (L/H)	0.75
	Go-Go 2 Cover shield	
	(R/H)	0.60
	- do - (L/H)	0.60
480201	Engine cover	0.25
	HS50 cover shield	
	top strip	0.20
	Compact Tank (L/H)	0.80
	Compact Tank (R/H)	0.80
	Touch-up paint matching	
	moped colours - Per tin	0.75

SERVICE TOOLS

		<u>Net</u>
485001	Ballrace fitting dolly	1.00
485002	Flywheel extractor	2.25
485003	Little end bush press	2.25
485004	Timing adjuster	1.75
485005	Clutch hub steady	3.00
485006	Fitting sleeve for clutch bearing	0.60
485007	Adaptor	0.50
485009	Ballrace extractor	7.50
485010	Flywheel steady	4.00
	Grease gun	1.95
485011	Oil seal tool	1.35
485012	Oil seal tool	1.50

\* Items marked thus carry 25% trade discount only.

HARGLO LIMITED

462 Station Road,

Dorridge,

Solihull,

West Midlands B93 8HB

Tel: KNOWLE (05645) 5835

ITALIAN DEALER NEWS No. 1

C.E.V. ELECTRICAL EQUIPMENT.

You may not realise that as sole U.K. Concessionaires for certain C.E.V. products we are landing regular consignments from them. The latest shipment includes lighting equipment for Morini and other Italian motorcycles.

We are pleased to offer these parts to you at very special prices subject to immediate order and prompt payment. The following items are available at the prices shown. All are suitable for Morini machines and individual items fit Harley Davidson, Ducati, Guzzi and Benelli.

We advise you to place your order by return.

	<u>Special Trade Price</u>	<u>Normal Trade Price</u>
	£.p	£.p
Indicator lamp (with rear screw clamping)	2.60	3.30
Indicator lamp (screw-on pattern)	2.75	3.60
Indicator lens	0.50	0.66
Rear lamp (large lens with in-built reflector)	9.20	11.20
Rear lamp lens (for above)	3.00	4.16
Headlamp complete (latest pattern)	14.50	18.88
Headlamp rim (for above)	1.80	2.40

The prices can only be maintained for orders received by 12th November 1976.

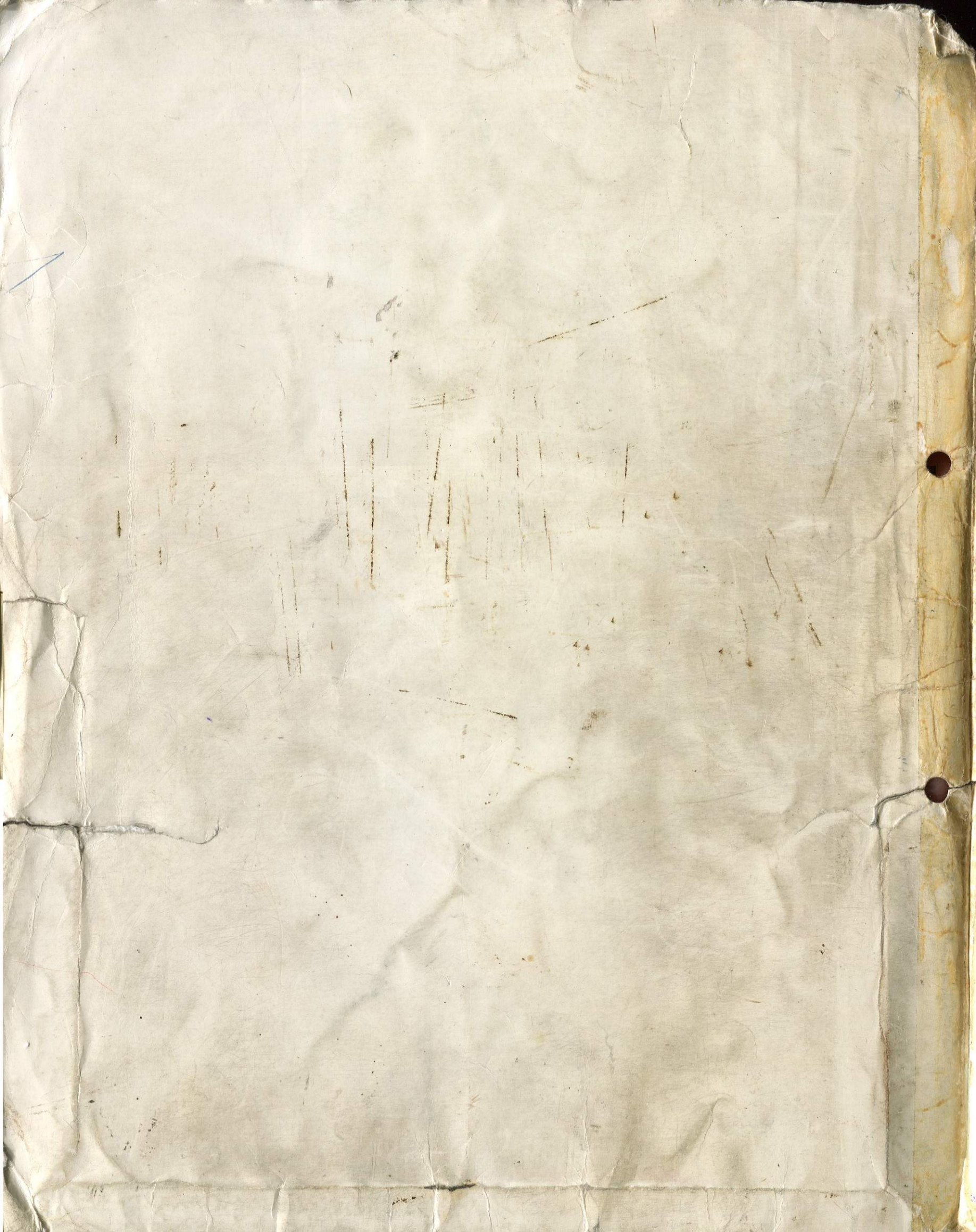

# IceniCAM Information Service

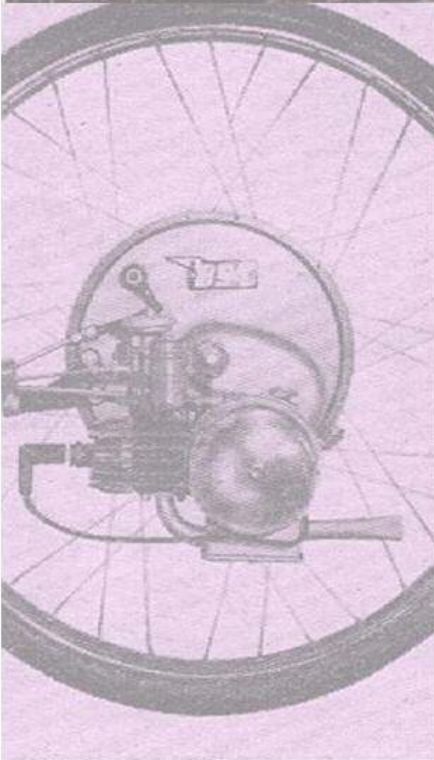

[www.icenicam.org.uk](http://www.icenicam.org.uk)