

IceniCAM Information Service

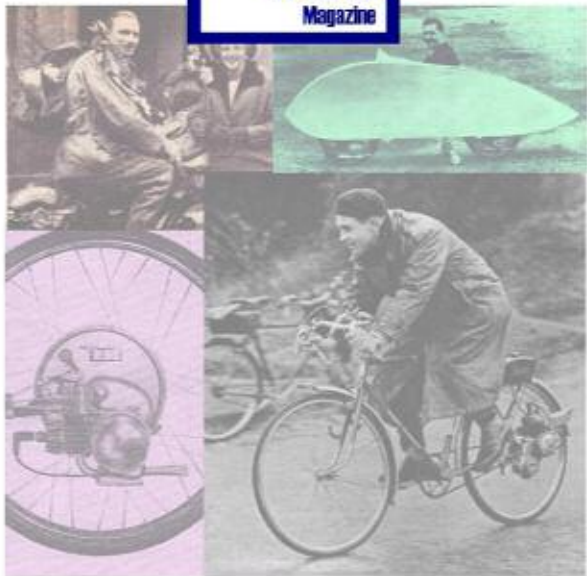

www.icenicam.org.uk

INSTRUCTION MANUAL

for

BSA

Winged Wheel

MODEL 34



Instruction Manual

for



WINGED WHEEL

Model W1

**B.S.A. MOTOR CYCLES LTD.
BIRMINGHAM 11**

*Telephone: Birmingham Victoria 2381
Telegrams and Cables: "Selmat," Birmingham.*

Service, Spares and Repairs Department
*Telephone: Birmingham Victoria 2234
Telegrams and Cables: "Selserv," Birmingham*

B.S.A. Motor Cycles Ltd. reserve the right to alter the designs or any constructional details of their manufactures at any time without giving notice.

CONTENTS

| | <i>Pages</i> |
|--------------------------------------|--------------|
| Brake | 11, 22 |
| Carburetter | 31 |
| Clutch | ...9, 10, 21 |
| Controls | 7, 9 |
| Cylinder Head and Barrel Removal ... | 28 |
| Driving | 14 |
| Decarbonising | 23 |
| Electrical Equipment | 35 |
| Exhaust Port | 25 |
| Fitting Unit | 4 |
| Fuel (Petrol) | 12 |
| Hub Bearings | 18, 23 |
| Ignition Timing | 3 |
| Lighting | 3 |
| Lubrication | 13 |
| Magneto | 35 |
| Maintenance and Adjustment | 18 |
| Petrol Tank Fitting | 7 |
| Piston Rings Gap | 3 |
| Running-in | 15 |
| Silencer Cleaning | 26, 27 |
| Sparking Plug | 30 |
| Starting | 14 |
| Technical Data | 3 |
| Transmission Oil | 13 |

TECHNICAL DATA.

| | |
|---|---|
| Petrol tank capacity (approx.) | Half gallon |
| "Petrol" mixture | Half gallon petrol and two measures oil (20 to 1). |
| Gearcase capacity | One-eighth pint (1½ measures) |
| Bore | 36mm. |
| Stroke | 34mm. |
| Capacity (swept volume) | 35c.c. |
| Piston ring gap | .006/.010in. |
| Ignition timing | Piston distance before top dead centre (t.d.c.) with points just opening 5/32in. |
| Plug point gap | .020in. to .022in. (.51mm. to .56mm.) |
| Contact breaker point setting | .018in. |
| Gear ratio | 18.7 to 1 |
| Rear tyre | 26in. x 1½in. (Dunlop Carrier) |
| Rear tyre pressure (lb.) | 40 43 46 49 52 55 |
| Rider's weight (stones) | 7 8 9 10 11 12 |
| Carburettor type | Amal 335/1 |
| Standard jet | 27 |
| Jet needle position | Centre notch |
| Dry weight of engine and wheel | 26½lb. |
| Dry weight of petrol tank/carrier | 3½lb. |
| Correct bulbs to use when lamps are fitted | { Front lamp 6v. 6w. Rear lamp 6v. .45A or .5A |

HOW TO FIT A B.S.A. WINGED WHEEL TO YOUR BICYCLE.

It is quite likely that the dealer from whom you purchase the B.S.A. WINGED WHEEL will do this work for you, but some users may prefer to fit the unit themselves, in which case the following notes will be of some help.

This work is carried out in three separate stages which are as follows:—

Fitting the actual unit to the frame.

Installing the petrol tank

Fixing the three control levers to the handle-bars

Since the machine will be ridden at much higher speeds than when used as a normal bicycle it will be subjected to considerably greater road shocks. It is strongly advised that the adjustment of the head and front wheel bearings are carefully checked, and that such attachments as mudguards are made secure. The use of spring washers is advised.

Fitting the Unit to the frame.

The overall width of the B.S.A. WINGED WHEEL is 4-11/16" between the face of the cone locking washer and the spindle locknut. This means that the unit will fit directly between the fork ends of a standard bicycle. There may be a slight variation as between one bicycle and another, amounting to about one-eighth inch more or less than this figure, but the fork ends will easily *spring* to this extent. If the width between the fork ends is appreciably less than 4-11/16", it will not be possible to fit the B.S.A. WINGED WHEEL conveniently, but if, on the other hand, the width is somewhat greater than this dimension, then the distance may be taken

up with suitable packing washers, always provided that there is enough length of spindle left at each side to allow for the proper fitting of the chain tensioners, mudguard stays and wheel spindle nuts.

On machines fitted with chain covers or oil baths it may be necessary to fit a washer on the spindle and a number 4 Sprocket to ensure that the brake drum does not rub.



Fig. 1. Fitting between fork ends.

Assuming that the width between the fork ends is suitable, it is only necessary to slacken the wheel spindle nuts right back, or better still remove them altogether, and to slide the wheel into position in the same manner as that adopted for the fitting of an ordinary bicycle rear wheel. Next fit the chain adjusters, the mudguard stays, and the wheel spindle nuts. In the case of a sports type frame,

the fork ends will be of the drop-out pattern and no chain adjusters are fitted. Screw the chain adjusters in or out until the correct tension is given to the pedalling chain, and then lightly tighten the wheel spindle nuts. When setting for chain tension, see that the wheel is also in correct track alignment.

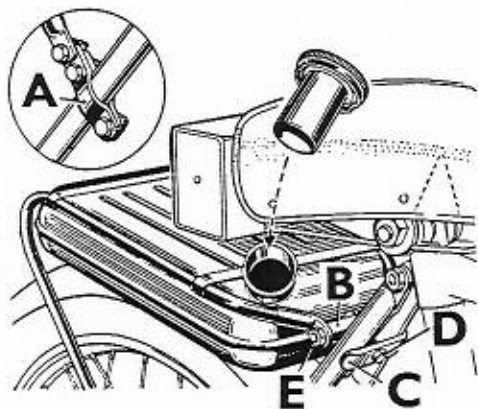

Fig 2. Tank filler cap and measure for oil.

Next turn your attention to the torque reaction clip *A*, Fig. 7, which fits over the chainstay. Alternative clips for round and D shape stays are provided with each engine. When tightening the clip bolt, it is essential that no side strain is placed on the unit by forcing the torque arm inwards or outwards to contact the face of the clip. If necessary, set the arm slightly, adjusting the offset to suit the individual conditions, or if the displacement is very small use washers as a packing between clip and arm. Tighten the clip bolt securely. It only remains for the wheel spindle nuts to be given a

final turn of the spanner, and the unit will be correctly fitted in position.

Petrol Tank.

This is built into a separate carrier which is supported on the backstays by two clips whose method of assembly is clearly seen at *A*, Fig. 2, and by a special attachment unit which goes above the backstay bridge. To attach this it is only necessary to place the bar *B* against the rear of the twin backstay tubes, fit the clip *C* in the position shown and insert and tighten up the centre locking pin *D*. In order to place bar *B* correctly against the backstay tubes it may be necessary to slacken the nuts *E* slightly, tightening them afterwards.

The operation of fitting the tank is completed when the petrol pipe between the tap and the carburetter is attached.

See that petrol tank is level—or with a slight downward tilt at rear—when fitted. Otherwise a quantity of fuel will remain in the forward end and prevent a full half gallon being accommodated when refilling.

On bicycles having a bent top rail a special attachment for the tank is necessary to ensure level fitting; this can be obtained through your local dealer.

When filling with fuel for the first time see that there is no airlock in the pipe.

Handlebar Controls.

When the B.S.A. WINGED WHEEL is delivered the three control cables are already attached to the unit, and it is therefore only necessary to lead the cables along the frame tubes and fix them with the rubber clips provided.

Throttle.

The combined throttle and strangler control *A*, Fig. 3, is mounted above the right handlebar, and attached by a clip in the normal manner as shown.

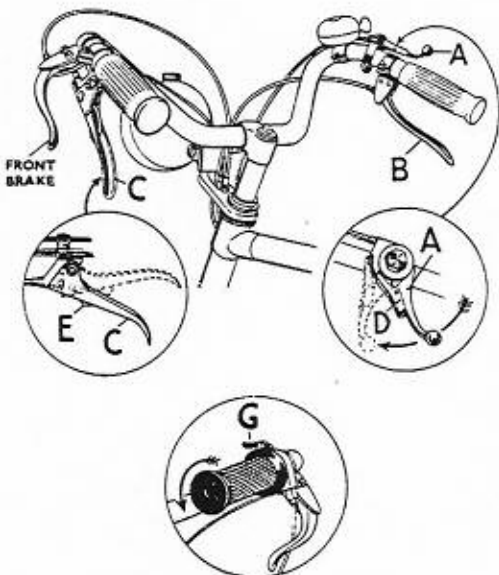

Fig. 3. Handlebar controls

Brake.

For convenience in driving the brake control should be mounted on the right handlebar, and since on the majority of pedal bicycles the rear brake control is normally on the left, and the front brake on the right, this will involve moving the front control lever to the left bar. Fig. 3 shows this arrangement with the B.S.A. WINGED WHEEL brake control at *B*.

Clutch.

The clutch control *C*, which also incorporates a ratchet retaining device, is mounted, in a similar manner to the brake lever, on the left handlebar.

Adjustments.

After the three control levers have been mounted on the handlebars as described above, it will be necessary in the case of the clutch and brake levers to adjust them properly. Full instructions for this are given on pages 21 and 22.

THE CONTROLS.

When fitting the controls, avoid sharp bends in the cables. It is advisable to fit the cable clips at the top and bottom of the front down tube and on the chainstay.

Throttle.

The carburetter throttle, which controls the amount of gas entering the cylinder, and therefore the amount of power developed by the engine and the speed of the cycle, is operated through a Bowden cable by lever *A*, Fig. 3, on the right handlebar. The throttle is opened when the lever is moved in a clockwise direction, as indicated by the arrow in the illustration.

The operation of the carburetter strangler for cold starting (see pages 10, 14 and 31) is also performed by the throttle lever when it is moved beyond the position at which full throttle is obtained. Full instructions with regard to this are given under the heading of "Starting" on page 14.

The twist grip throttle control which may be fitted, operates in an anti-clockwise direction to open throttle. To start from cold the trigger *G* Fig. 3, is pushed downward giving the necessary additional movement to the twist grip to bring the carburetter strangler into operation. The trigger returns to the normal position as the twist grip is closed, and thereafter restricts movement to the normal operational range.

Note that the adjuster at the carburetter end of the throttle cable is for adjustment of cable length only, and should not under any circumstances be used to give a "tick over" with the throttle closed, as this will cause the strangler to come into operation at full throttle, causing partial choking and increased petrol consumption.

Adjustment should be set so that the strangler flap starts to operate immediately after the lever or twist grip is taken past the full throttle stop when the trigger is lifted.

Clutch.

The clutch control lever is mounted on the left handlebar as shown at *C*, Fig. 3, and it operates

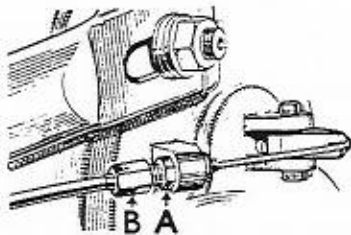

Fig. 4. Clutch adjustment.

the clutch withdrawal mechanism through a Bowden cable, the actuating lever at the other end of the cable being seen in Fig. 4.

When the clutch lever is pulled up as far as it will go towards the handlebar, the drive is disconnected between the engine and the rear wheel. The lever is locked in this position by a ratchet *E*, Fig. 3. To engage the clutch it is only necessary to disengage the ratchet by pressing it inwards, and then release the clutch lever. This must be done gradually in order to ensure smooth engagement.

Brake.

The rear brake control lever is mounted under the right handlebar and operates through a Bowden cable, the actuating lever at the other end being seen in Fig. 5. In common with all handlebar controlled brakes the large external expanding

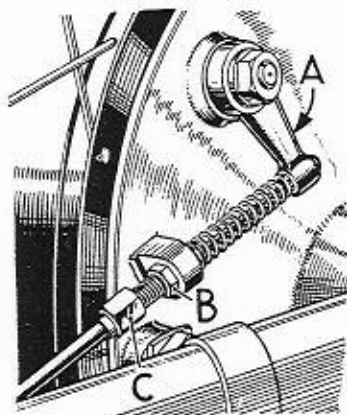

Fig. 5. Brake cable adjustment.

brake in the B.S.A. WINGED WHEEL is applied when the lever is pulled towards the handlebar and released when the lever is released.

PREPARING FOR THE ROAD.

Petrol.

The B.S.A. WINGED WHEEL engine operates on the PETROIL system, which means that engine oil is dissolved in the petrol and automatically provides correct lubrication without any further responsibility on the part of the rider, beyond that of supplying a mixture of a suitable strength whenever the petrol tank is refilled.

Instructions for the correct proportions of petrol and oil are marked on the tank filler cap (see Fig 2), which also incorporates a measure, and it will be noted that two fills of oil from this measure are correct for half a gallon of petrol, the resultant quantity of PETROIL mixture being sufficient to fill the tank. The mixing of the petrol and oil should preferably be carried out in a separate container before being put in the tank, to ensure that the oil is thoroughly dissolved, but if it is not practicable to do this, the oil should be poured into the tank first, followed by the petrol, and the bicycle should be vigorously shaken sideways a few times in order to make sure that the two liquids are properly mixed.

IMPORTANT.— Do not lay machine on its side for the purposes of adjustment or tyre repair without first removing or draining carburetter. The petrol-oil mixture is liable to drain out of the carburetter into the brake drum where the oil content will reduce braking efficiency.

TABLE I.
RECOMMENDED OILS.

(Summer and Winter)

| <i>Brand</i> | <i>Grade</i> |
|-----------------|----------------|
| Mobiloil | BB |
| Essolube | Esso 40 |
| Castrol | XXL |
| B.P. | Energo: SAE 40 |
| Shell | X100-40 |

*We also approve the use of the petrol/oil mixture No. 1 as supplied by the Shell-Mex and B.P. Two-Stroke Petrol Service.

Oil for Transmission.

There is a separate oil supply for the transmission gear, and before starting for the first time this must be filled to the correct level. Filler plug *A*, Fig. 6, is provided for this purpose.

The correct quantity of oil is $\frac{1}{4}$ pint (approx. 1 $\frac{1}{2}$ measures), and the recommended grades are the same as those given in Table I above.

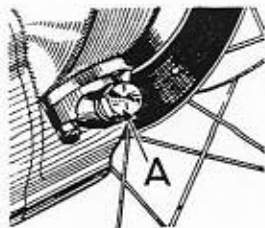

Fig. 6. Gearcase filler cap.

COVENTRY MOTOR MART LTD.,
86, LONDON ROAD,
COVENTRY

Starting.

First, turn on the petrol tap by pulling the knob out. Then if the engine is cold (*i.e.* if it has not run for a few hours, and the temperature has therefore fallen to atmospheric level), it will probably be necessary to close the strangler in order to ensure an easy start. To do this, press the trigger *D*, Fig. 3, inwards with the thumb and, holding it thus, open throttle lever *A*, by moving it in a clockwise direction to its fullest extent. The thumb may then be taken from the trigger, which will remain out of engagement until it is allowed to ratchet back.

Release the clutch by pulling up lever *C*, to its fullest extent, in which position the clutch will be held out by the ratchet *E*. Then mount the bicycle and pedal off in the normal manner. When a suitable speed has been obtained, depress the ratchet and gradually release the clutch lever. This will couple the engine to the rear wheel and cause the former to rotate, whereupon it should immediately commence firing.

As soon as the engine is running smoothly, which should not take more than a second or so, ease the throttle lever back slightly in order to release the strangler. The machine can then be ridden normally as described in the next section.

Driving.

The speed of the engine and therefore of the bicycle is controlled by the throttle lever and within the limits of the performance of the B.S.A. Winged Wheel it gives a uniform range of speed from a walking pace with the throttle nearly closed right up to the maximum speed on the level amounting to about 25 m.p.h. with corresponding lower speeds on hills.

Pedal assistance should never be necessary on the level except perhaps for starting, and against a strong head wind, but it is expected that a small amount of pedalling will be necessary occasionally on gradients, and the rider will rapidly learn by experience how best to assist the engine in this respect. The engine should never be allowed to labour, and it will be found that on quite severe gradients the pedalling does not call for much physical effort because it is only a matter of supplying a little extra power above and beyond that of which the engine is capable.

Any temptation to "drive off the brake," should be avoided as it is obviously futile to have the engine generating on one hand, and for that power to be absorbed on the other. When the occasion arises for stopping or slowing down, the throttle should be closed and the clutch must be disengaged before the brake is applied in order to avoid snatch in the transmission.

Running-in.

Running-in is really the most important period in the life of the engine, and the handling you give it during the early part of its life will determine what sort of service it is going to give you later.

If you try to put it through its paces too soon you will run the risk of seizure and other troubles which may have a lasting effect on the engine, and, in any case, until it is really run-in it will not be at its best. So give your engine a chance to settle down during the first 250 miles of its life.

Avoid sudden and sharp acceleration. Do not force it up hills, when a small amount of pedalling would ease the load.

Carry out the periodical maintenance details described later with faithful regularity

After the first 150 miles, release the drain screw *A*, Fig. 8 two turns which will allow any oil which may have accumulated to drain out. With the

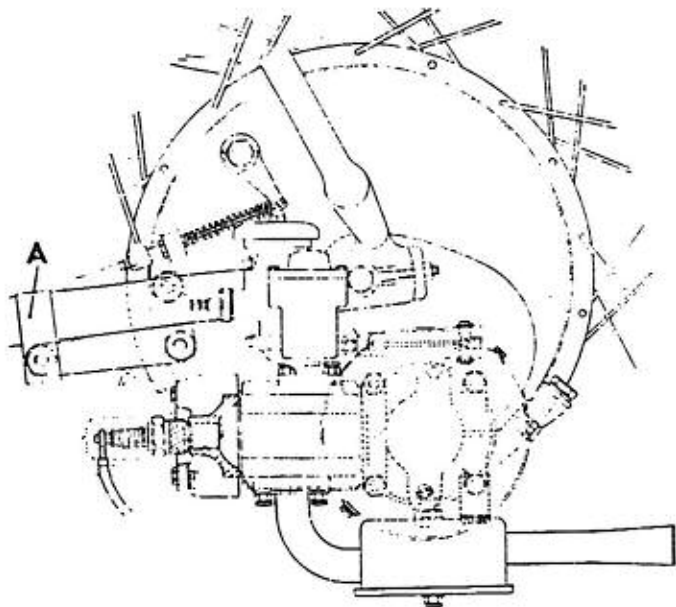

Fig. 7. Side elevation of unit.

petroleum lubrication system employed there is never a considerable quantity of liquid oil in the crankcase, but whatever oil there is should be drained away, and this is preferably done while the engine is warm immediately after a run, as the oil will flow

more freely and carry with it any foreign matter which may have found its way into the crankcase during the running-in process.

Make certain on replacing the screw that it is made quite tight in order to prevent loss of crankcase compression.

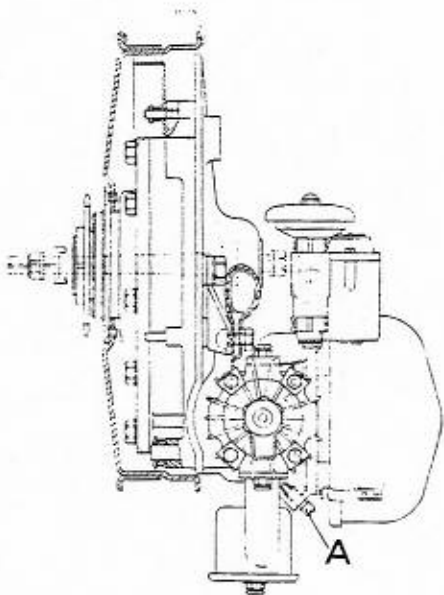

Fig. 8. Front elevation of unit.

Note. This drain screw only concerns the crankcase, and not the gearcase, which can only be emptied via the plug *A*, Fig. 6.

MAINTENANCE AND ADJUSTMENT.

General.

The amount of maintenance and adjustment of the WINGED WHEEL has been reduced to a minimum, but the following points may require attention from time to time and they should certainly be checked periodically, say once a week and rectify if necessary in the manner described below.

Hub bearing adjustment.

There are two sets of bearings in the hub, these being the cup and cone ball bearings for the spindle itself, and a separate cup and cone ball bearing for the pedalling gear sprocket and free wheel. These are all adjusted simultaneously when the following procedure is adopted.

First support the bicycle, either on a box under the bottom bracket or by a rope slung under the saddle in such a way that the rear wheel is clear of the ground. Next slacken off the offside wheel spindle nut *A*, Fig. 9, and then release the locking washer *B* by sliding it sideways along the spindle groove, sufficient to free the spanner flats on adjusting cone. Disengage the clutch by means of the lever on the handlebar and lock it in the free position by allowing the ratchet *E*, Fig. 3, to engage. Then with a spanner on the adjusting cone, either screw this in or out as necessary until the wheel can still be revolved freely, although but a slight further turn of the adjusting cone in a clockwise direction results in an appreciable tightening of the wheel.

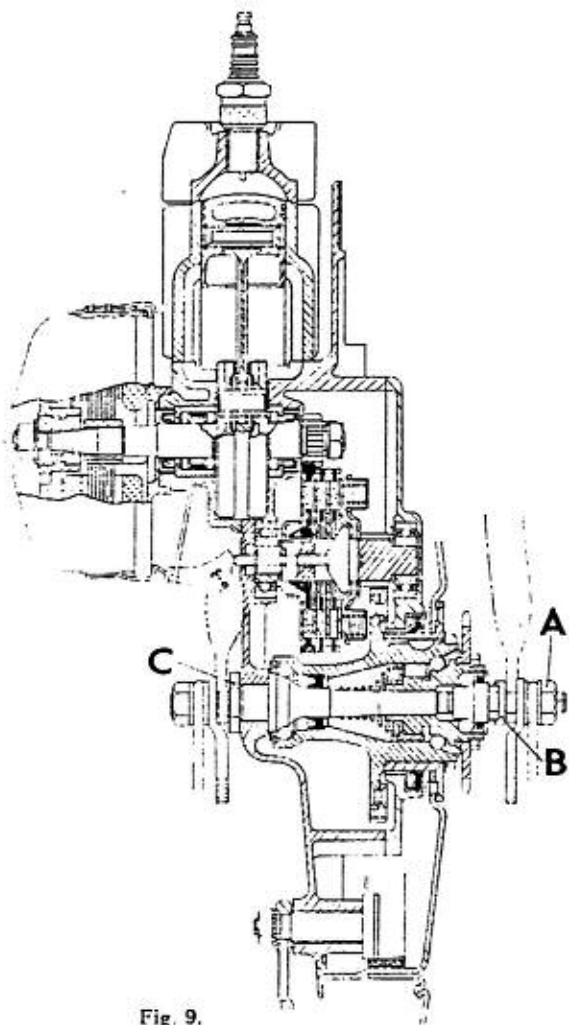

Fig. 9.

When this point has been reached it means that all the play in the bearings has been taken up, and any further tightening of the cone will put an actual thrust on the steel balls. This must be avoided at all costs, and the correct thing to do when the play has all been taken up as just described, is to unscrew the cone a small fraction of a turn. When the wheel is now grasped by the tyre and moved sideways it should be possible to feel a small amount of play, or shake, which should not exceed about 1/64th of an inch (*i.e.* just about enough to feel and no more). When this state of adjustment has been arrived at, lock the adjusting cone by returning the locking washer to its original position (cone may have to be slacked off slightly more if flats are not in line). Tighten rear spindle nut *A* and check play once more. Check that the chain sprocket is quite free to turn in the free wheel (anti-clockwise) direction. It may be found that the bearing has tightened a little, and readjustment will be required making allowance for the effect of the final tightening of the spindle nut.

Hub Lock Ring Adjustment.

This lock ring (Part No. 62-297) located immediately behind the chain sprocket, is locked firmly home before the unit is despatched from the works. However, every engine, irrespective of type, tends during the initial running-in period, to bed down. In the case of the Winged Wheel this can sometimes leave the lock ring a little slack. The symptoms are shown in excessive play at the wheel rim which can be mistakenly attributed to a slack wheel bearing adjusting cone. Under no circumstances should over-adjustment of the wheel bearings be permitted for this will only result in collapse of the wheel bearings, leaving the wheel play still in evidence.

The procedure for re-tightening the lock ring is as follows:

1. Remove wheel from frame.
2. Remove sprocket side spindle nut, washers and adjusting cone.
3. Lift out the sprocket complete with driving piece and spring.
4. Knock down tab washer from lock ring slots.
5. With a "C" spanner, tighten lock ring home as hard as possible (right-hand thread). With a narrow punch, knock the lock washer back into the lock ring slots.
6. Re-insert conical spring, narrow end first.
7. Replace sprocket and driving piece assembly.
8. Refit adjusting cone, washers and nuts.
9. Replace wheel in frame.

The foregoing may be necessary after some 250 to 750 miles have been covered. After a lengthy period involving some thousands of miles, the wheel bearing adjusting cone will need adjustment due to wear.

Clutch.

It has not been found necessary to provide any internal adjustment for the clutch, and the only item to be checked here is the actual control cable, which after a long period of use may tend to stretch slightly, with a consequent increase in the amount of free movement as indicated at *A*, Fig. 4, although the gradual reduction in the thickness of the clutch elements with the passage of time may tend to compensate for this. If there is insufficient free movement, the clutch springs may be prevented from exerting their full pressure on the plates, with a consequent liability to slip. If, on the other hand, there is too much play, the clutch will not be entirely

free when disengaged, and this will be evidenced by a tendency to drag, and for the cycle to creep forward instead of remaining perfectly stationary when the clutch is out.

The correct amount of play at the handlebar lever is approximately 1/16in. when the clutch is fully engaged, and if this is found to be incorrect it should be adjusted by releasing the locknut *A* and screwing the adjuster *B* in or out as necessary until the play is provided. Finally re-tighten the locknut *A* and check that the setting has not been disturbed during this operation.

Brake.

The control of the brake operation and its adjustment are carried out on similar lines to those described above for the clutch. The amount of free movement at the end of the brake lever in the direction of the arrow as shown at *A*, Fig. 5, before the brake is applied, is $\frac{1}{4}$ in. and if this is found to be incorrect it should be rectified by releasing the locknut *B* and turning the cable adjuster *C* in exactly the same manner as described for the clutch adjustment.

The internal expanding brake fitted to the B.S.A. WINGED WHEEL is of unusually generous dimensions, and the rate of wear is therefore extremely slow, but a time will come eventually after a very considerable mileage when all the available adjustment at the cable has been taken up. When this stage has been reached it is more than likely that the brake linings have worn beyond the safe limit, and the wheel should therefore be taken to your dealer or repairer for re-lining or other expert attention. We repeat, however, that this circumstance is not likely to arise until very many thousands of miles have been covered.

Engine.

This is automatically lubricated by the petrol system as described on page 12 and 13.

Other items.

These include carburetter, sparking plug and magneto contact breaker points (see pages 31, 30 and 36).

Gearcase.

This has a separate oil supply as described on page 13, and the only maintenance required is topping-up or draining and replenishing it from time to time. This can conveniently be done when the engine is decarbonised. The correct quantity of oil for the gearcase is one eighth of a pint (approx. $1\frac{1}{2}$ measures).

Hub.

This is packed with grease when the unit is built at the factory, and requires no attention until a major overall becomes necessary. The nearside spindle bearing lies within the transmission case, and is thus automatically lubricated.

Brake cam spindle.

An occasional drop of cycle oil will keep this adequately lubricated.

Cycle generally.

Do not forget to make an occasional check on the cycle itself (spindles, head, pedals, cotters and particularly mudguard attachment points). Also on the less mechanical parts of the Winged Wheel—tank attachment, torque arm clip bolt and anchor bolts, crankcase nuts and the inlet manifold nuts. Also oil the cycle parts and the control cables.

Decarbonisation.

Owing to the accessible design of this engine and the special attention which has been paid to ease of routine maintenance, decarbonisation is an

extremely simple matter, easily carried out even by the most inexperienced novice if the following instructions are observed.

The formation of carbon deposit is inevitable inside the combustion chamber, and at certain other places, in all internal combustion engines, because it is either the by-product of the process of combustion, or a residue from the temperature effect on the lubricating oil, or both. If the combustible mixture from the carburetter is a little on the rich side, due to the use of too large a jet, or to unnecessarily long periods of running with the strangler partly or fully closed, a deposit of carbon will be formed on the cylinder head and piston crown, and in the ports, which will be soft or sooty in texture. If, on the other hand, the formation of carbon is due to over-oiling (*i.e.* to running too rich a petrol mixture, see page 34), then the deposit will be much harder and more difficult to remove.

A study of the carbon deposit will provide a useful indication as to its cause, particularly if it is excessive in quantity. The main symptoms indicating an excessive amount of carbon deposit are an appreciable decline in power, a tendency for the engine to be rough and overheat, and for it to run erratically, particularly at low throttle openings. When a stage has been reached at which these symptoms are evident, decarbonisation is clearly overdue, and the wise owner of a small two-stroke such as the B.S.A. WINGED WHEEL will find that it pays to work to a definite schedule of decarbonisation on a mileage basis, instead of waiting for the engine to show signs of distress before undertaking this work. For this purpose Table II. is given as a useful guide.

TABLE II.

RECOMMENDED DECARBONISATION PERIODS.

| <i>Item.</i> | <i>Decarbonise every</i> |
|--------------------------|---|
| Exhaust Port | 1,000 - 1,200 miles. |
| Silencer | Examine at same time as exhaust port, and decarbonise if necessary. |
| Cylinder Head and Piston | 2,000 - 2,400 miles. |

Exhaust Port.

Accumulated carbon in the exhaust port (*i.e.* in the cylinder aperture), and also in the first inch or two of the pipe, is the most prolific cause of power loss, because it has the effect of reducing the area of the orifice through which the exhaust gas has to pass on its way out of the cylinder, and it therefore offers increased back pressure.

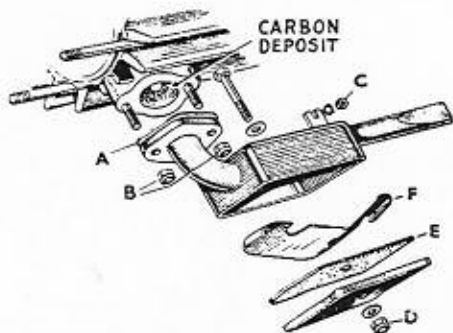

Fig. 10. View into port with pipe off and silencer dismantled.

To decarbonise the port it is necessary to detach the exhaust pipe and silencer. The former is held on its flange, with a special jointing washer *A*, by the two nuts *B*, Fig. 10, and the silencer body is supported by a slotted strap, attached by nut *C*. The complete exhaust system can be lifted clear when the nuts *B* are unscrewed, and nut *C* is slackened.

To remove the carbon from the exhaust port, turn the engine until the piston is at the bottom of its stroke. This can be seen by looking through the port and noting that in this position the piston has just completely uncovered it. Now take an

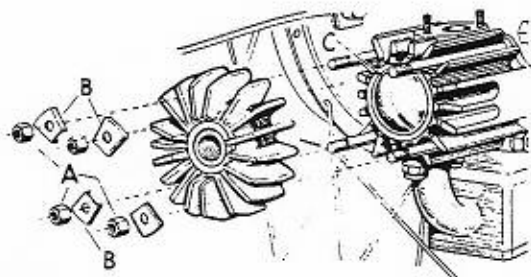

Fig. 11. Head off piston at t.d.c.

old penknife or similar tool and carefully scrape away the carbon in the port. Then wipe it round with a piece of rag and turn your attention to the exhaust pipe. Any appreciable amount of carbon which has accumulated in the pipe will be at its entry, and it can easily be scraped out.

Silencer.

While the exhaust system is detached from the cylinder it is advisable also to dismantle the silencer by removing nut *D*, together with its washer, and

lifting the lid, noting carefully that a special joint washer *E* is interposed between the silencer and the lid. Take care not to damage this, as it is liable to affect the exhaust note adversely if replaced in an unsound condition.

The internal baffle *F* can now be taken out and this, together with the inner walls of the silencer, should be carefully cleaned of any carbon which has formed, after which the silencer can be re-assembled.

An absorption type cylinder of improved design is fitted to later models.

The sound absorption pack (*C*), Fig. 11A, will eventually become choked, and should be replaced by a new one at intervals of about 5,000 miles. To replace this pack, remove silencer as described on page 26, then take off nut *A*, Fig. 11A; this allows the rear end of the silencer body (*D*) to be separated from the front end (*B*), when the old absorption material can be pulled out.

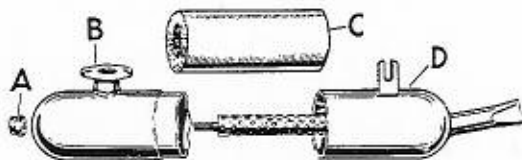

Fig. 11A.

Clean the perforated tube of any carbon or oil, fit the new pack (obtainable from your Winged Wheel dealer) and reassemble. Remove any carbon deposit which may have collected in the small flanged inlet pipe before refitting silencer.

Cylinder Head and Piston.

Before removing the cylinder head the sparking plug should be taken out, and examined for condition as described on page 30. To remove the head, unscrew the four nuts *A*, Fig. 11, putting these on one side carefully together with the saddle washers *B*. Then lift the head clear of the barrel and remove the carbon from its inner surface by means of a suitably shaped tool, bearing in mind that the head is made of aluminium alloy and is therefore comparatively soft and easily damaged by careless use of the decarbonising tool. It is particularly important in this respect that the joint face *C*, which makes contact with the cylinder barrel, should not be scratched or otherwise damaged, or the running of the engine will be impaired.

Turn the engine until the piston is at the top of its stroke (*i.e.* at the outer end of the cylinder), and then carefully remove the carbon from its surface in the same way as described for the head noting that the piston is also of aluminium, and therefore equally liable to suffer damage if not carefully handled.

Special Note.—In normal circumstances there is no need to disturb the cylinder barrel when decarbonising, although it will be noted that it is free to slide off when the head is removed.

If the barrel should be disturbed at the crankcase joint when removing the head, remake the joint using a new paper washer and a very small quantity of jointing compound. The joint between head and barrel is metal to metal and requires no gasket, or jointing. There is, however, no objection to the use of a reliable jointing compound on this joint if preferred.

After decarbonisation in the manner described, the engine can be re-built without difficulty. Carefully slide the cylinder head into position by allowing

the four long studs to occupy their proper positions between the appropriate pairs of fins, and then replace the four saddle washers *B*, followed by the nuts *A*. Note that the fins nearest the brake drum are shorter and its head must be fitted the correct way round. Tighten the head nuts evenly, a little at a time and do not use undue force.

Refit the sparking plug, having satisfied yourself that it is in correct working order as described, and finally replace the silencer and exhaust pipe, not forgetting the flange jointing washer *A*, Fig. 10, which must be renewed if it is damaged in any way.

The engine is now ready for immediate service. Check the cylinder head nuts, inlet manifold nuts, carburettor clip and exhaust pipe nuts, after the engine has run for a short time and settled down.

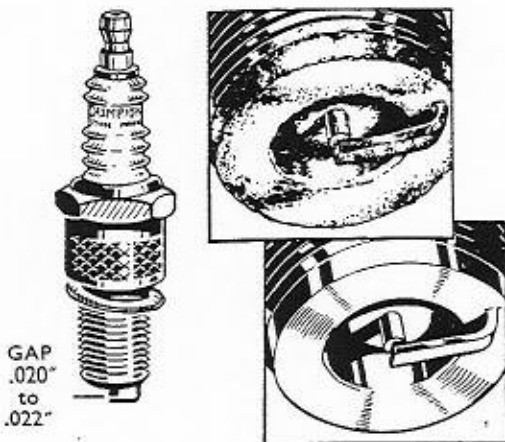

Fig. 12. Sparking plug.

Sparking Plug.

The sparking plug is of great importance in satisfactory engine performance, and every care should be taken to fit the correct type when replacements are necessary. This is Champion Type N7, as illustrated in Fig. 12.

Remove the sparking plug every 1,000 miles for inspection. If the carburation system is in correct adjustment the sparking plug points should remain clean almost indefinitely. An over-rich mixture from the carburetter will, however, cause the formation of a sooty deposit on the points and, later, on the plug end face (as upper view, Fig. 12). If therefore such a deposit is found, clean it off carefully and check your carburetter. Too high a proportion of oil in the petrol mixture will also cause plug fouling (see page 12).

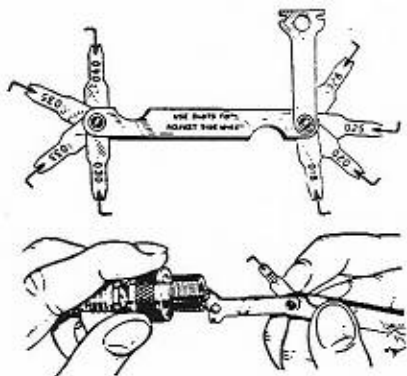

Fig. 13. Sparking plug gauge.

A light deposit due to any of these causes can easily be cleaned off, but if it is allowed to accumulate, particularly inside the body, the plug may spark internally with an adverse effect on the

engine performance if, indeed, it does not stop the engine altogether. The plug should be cleaned and tested at regular intervals, and it is suggested that this service be performed at your garage on a special "Air Blast" service unit. If eventually the cleaning process fails to restore the plug to its original condition of efficiency, it should be replaced by a new one.

When inspecting a plug, also check the gap between the points. This should be .020-.022 in. and adjustment should be made by bending the side wire (Fig. 13). **Never attempt to move the centre electrode**, and it is always advisable to use the special plug gap tool illustrated, obtainable at 2/- from any Champion Plug stockist or from the Champion Sparking Plug Co. Ltd., Feltham, Middlesex. Feeler gauges are attached to verify correct gap.

When refitting the plug, make sure that the copper washer is not defective in any way. If it has become worn and flattened, fit a new one to ensure obtaining a gastight joint.

The Amal Carburetter.

The Amal carburetter fitted to the B.S.A. WINGED WHEEL has been specially developed for this type of power unit. In general it follows the main principles embodied in the standard Amal motor cycle carburetter, but it also incorporates an automatic strangler device *A*, Fig. 14, which comes into operation when the throttle lever is opened beyond its normal maximum as described in page 8 and 14. This item calls for no maintenance whatsoever, but if the throttle slide *B* is removed for any reason care should be taken to ensure that the small tongue at the lower end of the strangler *A* (not seen in the illustration), engages properly in the groove *C* when re-assembling.

The needle jet *D* screws horizontally into the mixing chamber *E*, and the main jet *F* is inserted from underneath.

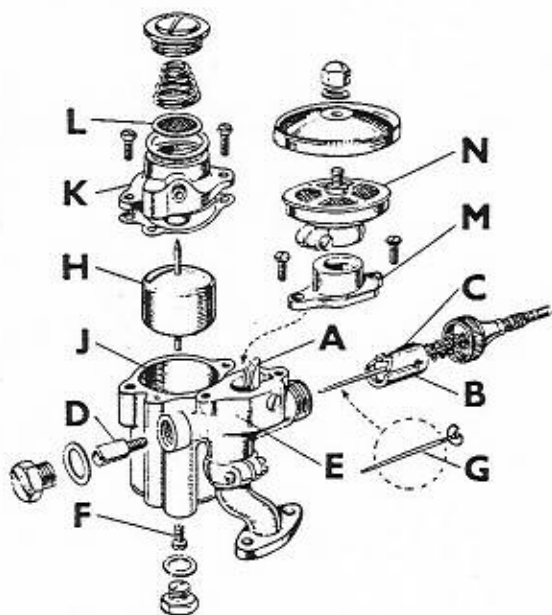

Fig. 14. Amal carburetter.

Sliding in and out of the needle jet as the throttle is moved is the jet needle *G*, which, being tapered, varies the effective jet size in accordance with the throttle position, thus ensuring correct mixture strength at all times. It will be seen that the jet needle is located in the throttle slide by means of a special spring clip engaging in one of the notches at its outer end. If the clip is moved to another notch it will affect the mixture strength, a notch

nearer the end giving a weaker mixture, and a notch in the other direction (*i.e.* nearer the tapered shank) giving a richer mixture.

The float *H* maintains the correct level of petrol in the float chamber *J*, whose cover *K*, held by two screws, incorporates a gauze filter *L*.

Attached to the top of the mixing chamber is stub *M*, also held by two screws, and this carries the combined flame trap and air filter *N*.

Petrol Filter.

The gauze petrol filter *L* should be inspected and cleaned if necessary at regular intervals, and this can conveniently be done every time the engine is decarbonised as described on pages 23 to 29.

Air Filter.

This is built into the carburettor intake bell and, as it is of the oil dip type, it requires to be dismantled and cleaned periodically, say, every thousand miles. To do this, release the clip bolt, and take the bell off. Soak it thoroughly in petrol, allow it to dry, and then submerge it in light engine oil for a few minutes. Take out and allow the surplus oil to drain off.

Float Chamber.

After very considerable mileages a small amount of foreign matter may accumulate in the bottom of the float chamber *J*, and if the cycle is used during all weathers there may also be one or two beads of water. The float chamber can easily be cleaned out with a piece of dry rag, and when the float is subsequently replaced make sure it is the right way round, with the taper point of the needle upwards.

Needle Jet.

This normally requires no maintenance, as any foreign matter which finds its way to this point is not likely to become lodged in the jet, owing to its size and the action of the needle.

Jet Needle.

As described above, the position of the jet needle affects the mixture strength. When the B.S.A. WINGED WHEELS are sent out from the factory the clip is engaged in the centre notch, which gives the best average setting. If it is felt, however, that the mixture is somewhat on the weak side, and possibly a little more power is necessary, although this will probably be at the expense of a slightly heavier fuel consumption, this can be provided if the clip is moved inwards to the next notch. Similarly, the mixture can be weakened in the interests of extreme economy, although with a slight power loss and a tendency to overheat, if the clip is moved outwards to the next notch. Unless you have had considerable experience of carburetter tuning, however, you will be well advised to act in this respect on the advice of your dealer.

Main Jet.

As can be imagined in the case of a small engine such as the B.S.A. WINGED WHEEL, the hole in the main jet is very tiny, and can easily be choked by even microscopic foreign matter. Irregular or erratic running may be attributed to this cause, and if the jet should be stopped up it will be found in most cases that it can be cleaned by placing it between the lips and blowing sharply. This method of clearing the jet is preferable to poking the dirt out with a piece of wire because

this operation is liable to damage the jet orifice with a consequently adverse effect on performance and consumption.

It is rare that the main jet will become choked. There is, however, a very small hole in the float chamber cap *K*, between the gauze filter *L*, and the float needle valve. It is much more likely that stoppage of this hole may be the cause if petrol starvation is experienced. Clear by similar action to that advised for the main jet, and in addition, carefully dry out the filter chamber below the gauze filter in case water has accumulated above the feed hole.

WICO-PACY ELECTRICAL EQUIPMENT. DESCRIPTION.

This Flywheel Ignition Generator Unit embodies two assemblies, namely the flywheel and the stator which carries the ignition coil, lighting coil, contact breaker unit and condenser. The cam is fitted on to the crankshaft, located by a key and held in position by the flywheel.

The ignition unit provides a high performance spark output over a very wide range of speeds, about 9,000 volts being obtained, at only 350 r.p.m. rising to 12,000 volts at 6,000 r.p.m., and it has been found possible to maintain a large enough air gap between rotor and stator to ensure a trouble-free system.

A characteristic of the magneto is that its spark output will not vary over a wide timing range, thus rendering frequent adjustment of the contacts unnecessary, and at the same time allowing a fair tolerance for the accuracy of the setting. A further feature of the magneto are the accessibility and ease of adjustment of the contact breaker without the necessity of removing the flywheel.

The lighting coil is energized by the three magnetic units which concentrate a powerful magnetic charge within a small space and volume, the characteristic being such that a brilliant light is obtained without flickering at a low speed, while the rise of output above the rated wattage is sufficiently low to protect the lamps from serious overloading at maximum engine speeds. One of the three magnet units also energizes the ignition coil.

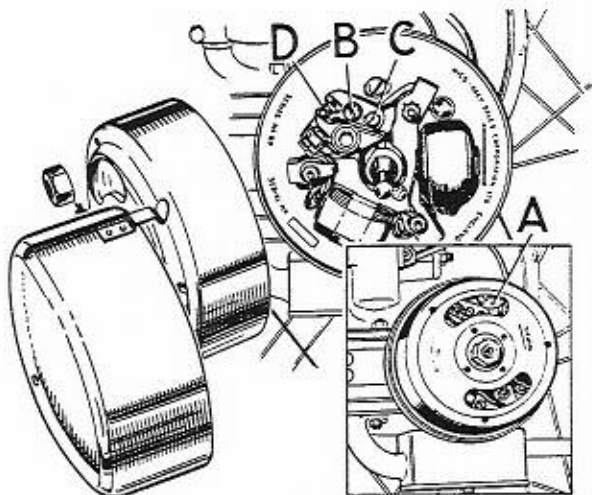

Fig. 15. Wipac Migenag Series 90.

RUNNING MAINTENANCE.

The magneto requires very little maintenance and if the following notes are observed the life of the machine should prove trouble-free.

Check and if necessary readjust the contacts once every 5,000 miles (see page 37).

Occasionally clean the contacts by inserting a dry smooth piece of paper between them and withdrawing while the contacts are in the closed position. Do not allow the engine to run with oil or petrol on the contacts or they will start to burn and blacken. If they do, lightly polish with a piece of smooth emery cloth, and wipe clean.

Adjustment of Contact Breaker Points.

Turn the engine over until the breaker points are seen to be fully open through the aperture *A* in the flywheel (Fig. 15), and measure the gap with a feeler gauge. It should be .018in. If the points need adjusting, loosen the screw *B* which locks the breaker plate and move the latter, to give the proper point setting, by turning the eccentric headed screw *C*. Then lock the plate securely again by tightening screw *B*. The breaker plate moves about the axis of the breaker arm stud and thus ensures proper alignment of the contact surface.

The breaker point setting should only be adjusted in the manner described and AT NO TIME SHOULD THE FIXED CONTACTS BE LOOSENED OR THE BREAKER ARMS BENT TO PROVIDE ADJUSTMENT.

The moving contacts are integral with the breaker arms. If the contact points need replacing it is recommended that both the fixed and movable points be replaced at the same time.

If the magneto requires any attention beyond that described above, it is recommended that the complete machine should be sent to us or to an authorised WIPAC service station.

MILLER ELECTRICAL EQUIPMENT.

It may be found that a magneto of Miller manufacture is fitted. A special instruction booklet is

then included in the literature provided with the unit, but a summary of information is provided here. The makers' type reference is B.S.19.

A rotating flywheel with cast-in magnets is used, and this revolves about pole pieces and coils fixed to the stator plate which is secured to the crankcase by two screws. (Check these screws occasionally and keep them tight).

The contact-breaker cam is formed by an internal extension of the flywheel hub. See makers' booklet for illustration.

Contact Breaker.

After removing the magneto cover, the contact breaker is visible and accessible through one of the slotted holes in the flywheel. It is important that at all times the contact breaker points (contacts) should be free from oil or grease. To clean, use a piece of fine emery cloth and after use wipe with a petrol moistened rag.

Contact Breaker Setting.

The contact breaker gap is set accurately before leaving the works at .018in., but occasionally adjustment should be made to maintain this. Adjustment is necessary owing to the wear of the lever heel. It is advisable to check the gap at 500 miles service and thereafter when full decarbonising is undertaken (2,000/2,400 miles).

To Adjust.

First revolve the flywheel so that the contact lever is lifted to its highest position on the cam; then loosen the adjuster contact plate fixing screw (which is immediately under the fixed contact) just sufficient to allow the contact plate to move with

pressure from a screw driver to the correct position of .018in. between the contacts, then tighten the fixing screw.

Timing.

It is essential to set the contact breaker maximum gap (see above) before any attempt is made to "time" the magneto. A Woodruff type key, fitted in the seating in the taper end of the crankshaft, locates the flywheel and cam for approximate timing position.

Final exact timing is made by setting the stator plate with the fixing screws central in the slots. Turn the flywheel clockwise until the piston has travelled $5/32$ in. down from its top-dead-centre position, and check if the contact breaker points are just parting (use a .002in. feeler gauge). If the points are more than .002in. open, loosen the stator plate screws and turn it a fraction anti-clockwise, re-tighten and re-check piston position and points opening. If the points have not opened at all, move the starter plate in the opposite direction (clockwise) and re-check.

The adjustment required will be very small.

BE SURE TO TIGHTEN THOROUGHLY THE STATOR PLATE SECURING SCREWS.

Lubrication.

Every 2,000 miles apply a few drops of thin oil to the felt cam lubricator.

At major overhauls, remove contact breaker lever and very lightly smear the pivot with thin oil.

High Tension Cable.

If this shows signs of cracking or perishing it should be replaced by use of 5mm. or 7mm. cable (P.V.C. covered recommended). To release cable

from the magneto, take out the two screws which secure the cable retaining pressing, then pull out cable from "pick-up." When replacing, use a thick needle or similar tool to make an aperture in the conductors of the cable to receive the solid wire lead from the high tension coil.

Lighting.

A 9 watt output is available at normal engine speeds, and current regulation is automatic to avoid excessive bulb overloading. Use bulbs as recommended on page 3.

Dismantling.

Follow the makers' separate instructions.

Re-assembling.

When re-assembling be sure to fit the flywheel locating key (see note in "Timing").

Do not tap the flywheel on its taper, or this may disturb the set of the crankshaft. Draw the taper joint tight by screwing up the centre attachment nut very securely.

IMPORTANT NOTE. LIGHTING.

If the lighting generator incorporated in the electrical equipment is used, it should be remembered that the output is considerably higher than the normal cycle dynamo set, and the correct type of bulbs must be used. Check also that the switch arrangement ensures that the headlamp lights just before the tail lamp. If the rear lamp comes into circuit even fractionally before the headlamp, the full current from the generator will cause immediate failure of the bulb.

If a new lighting set is used a model designed for Autocycle use is recommended. You are reminded that the illumination of the rear number plate is required by law.

PROPRIETARY INSTRUMENTS FITTINGS AND ACCESSORIES

No expense is spared to secure as standard equipment the most suitable and highest quality instruments and accessories. Nevertheless, the Company's guarantee does not cover such parts, and in the event of trouble being experienced the parts in question should be returned to and claims made direct on the actual manufacturers, who will deal with them on the terms of their respective guarantees, as follows:—

Carburettor: Messrs. Amal Ltd., Perry Barr, Birmingham.

Electrical Equipment: Messrs. Wico-Pacy Sales Corporation Ltd., Bletchley, Bucks.

Messrs. H. Miller & Co. Ltd., Aston Brook Street, Birmingham, 6.

Sparking Plug: Messrs. Champion Sparking Plug Co. Ltd., Feltham, Middlesex.

Tyre: Messrs. Dunlop Rubber Co. Ltd., Fock Dunlop, Birmingham.

SPECIAL NOTE.

Prompt attention to all claims under guarantee will be ensured if your covering letter gives:—

- (1) Make, year and model and Engine No.
- (2) Date of purchase and name of dealer from whom purchased.

Engine number is stamped on the casting above the oil dipstick hole.