



# SPARE PARTS LIST for 'TT9' CARBURETTER (with Type 302 Float Chamber).

## Price List of MIXING CHAMBER PARTS.

COMPONENT	FOR TYPE 15T.T.9		FOR TYPE 10T.T.9		
	PRICE s. d.		PRICE s. d.		
Mixing Chamber Body (Light Metal) .. .. .	} Specify Engine details	60 0	} Specify Engine details	65 0	
Mixing Chamber Top .. .. .		175/312		5 0	175/313
Mixing Chamber Cap .. .. .		175/316	5 0	175/317	5 0
Air Cable Adjuster .. .. .		2626	6	2626	6
Air Cable Adjuster Locknut .. .. .		2627	2	2627	2
Throttle Cable Adjuster .. .. .		175/314	6	175/314	6
Throttle Cable Adjuster Locknut .. .. .		175/315	2	175/315	2
Air Barrel Top .. .. .		2507	1 0	2507	1 0
Choke Adaptor, 1" Bore .. .. .	} Machined in position .. with	175/109	25 0	—	—
Choke Adaptor, 1 1/16" Bore .. .. .		} Mixing Chamber Body which should be sent to Amal, Ltd. ..	175/102	25 0	—
Choke Adaptor, 1 1/8" Bore .. .. .	—		—	—	—
Choke Adaptor, 1 1/16" Bore .. .. .	175/101		—	25 0	—
Main Jet .. .. .		3326	1 6	3326	1 6
Jet Choke Tube .. .. .		3438	2 6	3438	2 6
Needle Jet .. .. .		3970	2 6	3970	2 6
Jet Needle .. .. .		3971	3 0	3971	3 0
Jet Needle Clip .. .. .		4/230	6	4/230	6
Throttle Valve (Please state number of cut-away) .. .. .		175/310	8 6	175/311	8 6
Throttle Valve Spring .. .. .		175/308	1 0	175/309	1 0
Air Valve .. .. .		2502	1 6	2502	1 6
Air Valve Spring .. .. .		2558	4	2558	4
Jet Holder .. .. .		15/625	5 0	15/625	5 0
Jet Holder Plug Screw .. .. .		3348	1 6	3348	1 6
Adaptor Washer .. .. .		134/107	2	134/107	2
Float Chamber Arm Washer .. .. .		36/006	2	36/006	2
Pilot Needle .. .. .		2981/2967	2 0	2981/2967	2 0
Pilot Needle Insert .. .. .		2966	1 6	2966	1 6
Pilot Needle Spring .. .. .		2980	3	2980	3
Pilot Needle Spring Catch .. .. .		2982	2	2982	2
Nipple Holder for Air Valve .. .. .		2503	2	2503	2
Carburetter Cable Nipple .. .. .		2629	2	2629	2
Small Plug Screw .. .. .		2403	3	2403	3
Adaptor Location Peg .. .. .		134/105	4	134/105	4
Outlet Clip for 1 1/8" Outlet .. .. .	} State Material of Mixing Chamber Body, i.e., Brass or .. Light Metal ..	27/073	2 6	—	—
Outlet Clip for 1 1/4" Outlet .. .. .		27/073	2 6	—	—
Outlet Clip for 1 3/8" Outlet .. .. .		—	—	27/072	3 0
Outlet Clip for 1 1/2" Outlet .. .. .		—	—	27/072	4 0
Outlet Clip Screw .. .. .		1962	9	1962	9
Air Intake Tube, 1" Bore .. .. .	} Machined in position with Mixing Chamber Body which should be sent to .. Amal, Ltd. ..	175/114	10 0	—	—
Air Intake Tube, 1 1/16" Bore .. .. .		175/113	10 0	—	—
Air Intake Tube, 1 1/8" Bore .. .. .		—	—	175/118	10 0
Air Intake Tube, 1 3/8" Bore .. .. .		—	—	185/121	10 0
Air Intake Tube, 1 3/8" Bore .. .. .		—	—	175/117	10 0
Lock Ring for Air Intake Tube .. .. .		175/115	4 0	175/119	4 0
Mixing Chamber Cap Lock Spring .. .. .		175/306	1 6	175/307	1 6



# T.T.9 Mixing Chamber

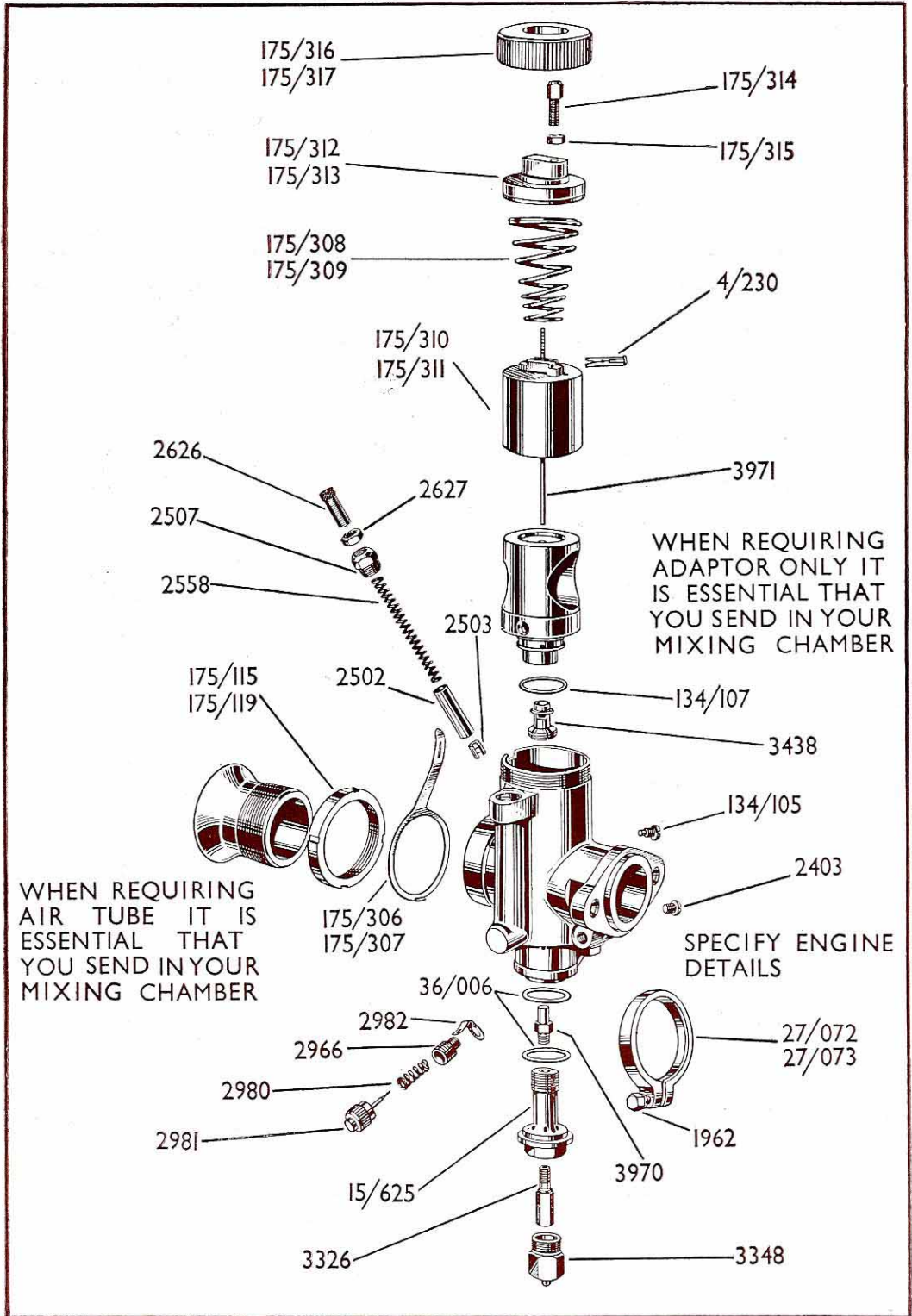

PRICES ETC., REFER TO PAGE ONE.

# Type 302 T.T. Float Chamber

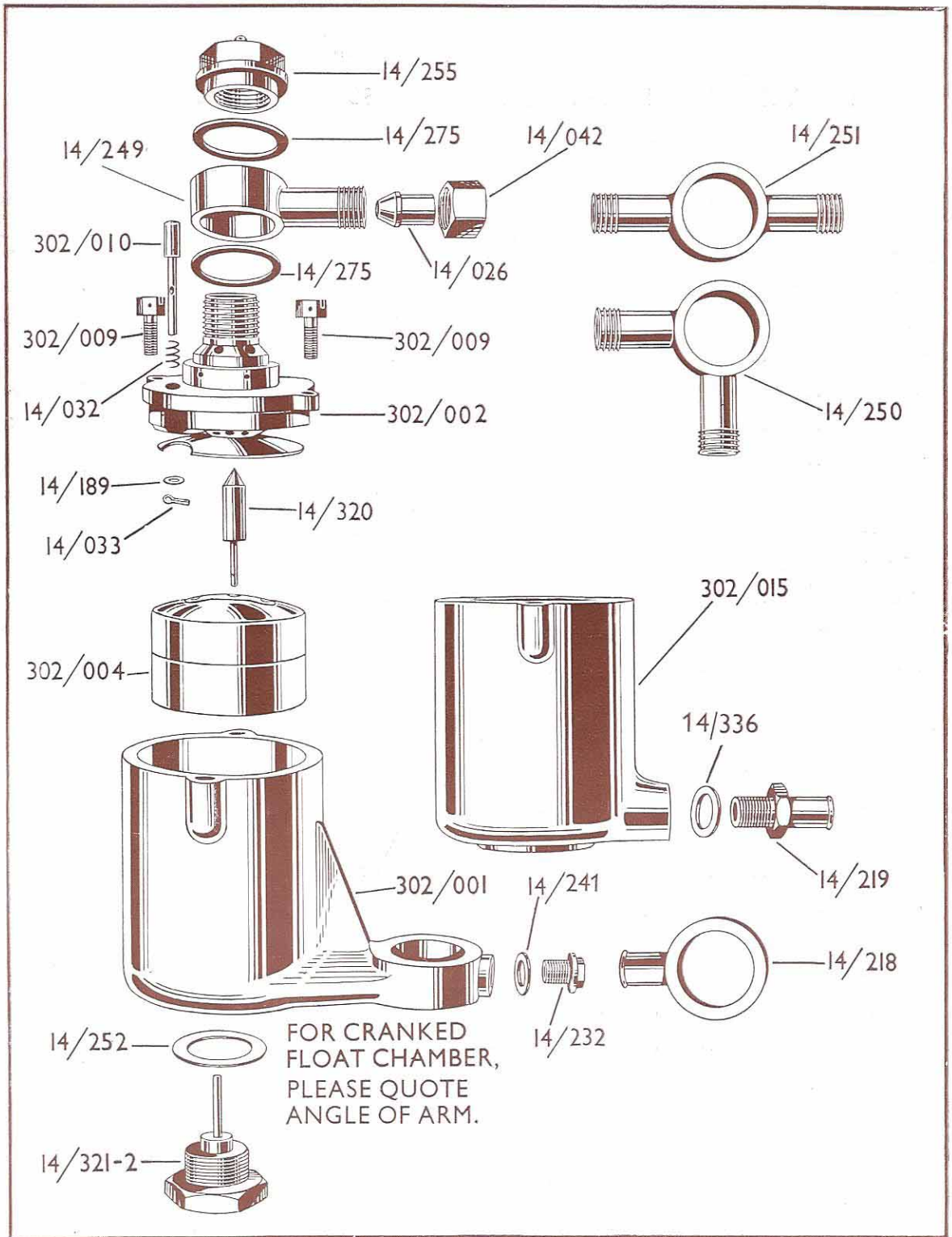

PRICES ETC., REFER TO PAGE FOUR.

# SPARE PARTS LIST

for TYPE 302 LARGE T.T. TOP FEED FLOAT CHAMBER

COMPONENT	TYPE 302/1	(Remote) TYPE 302/3	LIST PRICE S. D.
	PART No.	PART No.	
Complete Float Chamber .. .. .	302/1*	302/3	70 0
Float Chamber Body only .. .. .	302/001*	302/15	30 0
Cover complete with Baffle .. .. .	302/002	302/002	20 0
Cover Fixing Screws .. .. .	302/009	302/009	4
Tickler .. .. .	302/010	302/010	10
Tickler Spring .. .. .	14/032	14/032	2
Tickler Cotter .. .. .	14/033	14/033	1
Tickler Washer .. .. .	14/189	14/189	1
Float .. .. .	302/004	302/004	5 0
Float Needle .. .. .	14/320	14/320	2 0
Base Plug and Guide .. .. .	14/322	14/322	3 0
Base Plug Washer .. .. .	14/252	14/252	2
Banjo, Single .. .. .	14/249	14/249	3 9
Banjo, Twin, 90° .. .. .	14/250	14/250	7 6
Banjo, Twin, 180° .. .. .	14/251	14/251	7 6
Banjo Nut .. .. .	14/255	14/255	1 6
Banjo Washers .. .. .	14/275	14/275	2
Petrol Union Nuts .. .. .	14/042	14/042	9
Petrol Union Nipples .. .. .	14/026	14/026	5
Plug Screw .. .. .	14/232	—	6
Plug Screw Washer .. .. .	14/241	—	1
Float Chamber Connection .. .. .	—	14/219	3 9
Float Chamber Connection Washer .. .. .	—	14/336	2
Mixing Chamber Connection .. .. .	—	14/218	2 6

\*When ordering state angle if any required.

*All Prices are subject to alteration without notice.*

## AMAL LTD., BIRMINGHAM, England.

Telephone: BIRchfields 4571 (5 lines).

Telegrams: Amalcarb, Birmingham.

# IceniCAM Information Service



[www.icenicam.org.uk](http://www.icenicam.org.uk)