

*Fa. König*

**CATALOGO  
GANASCE  
6/75 EXPORT**



**Brake Shoes  
Bremsbacken**

**ADLER spa  
ROVERETO**



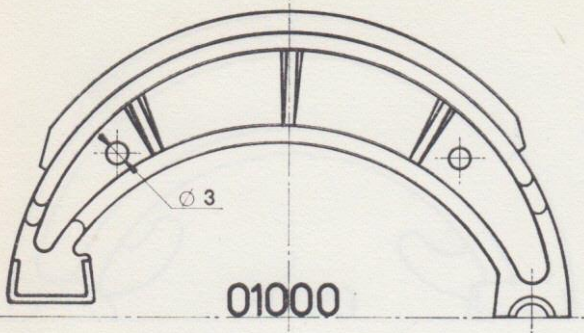

Ø 90 x 20

## VICTORIA

Vichy IV, Super 126,  
Avanti SM 51, SM 52,  
Luxus, Superluxus type 107  
Vichy standard type 117

**o1000**

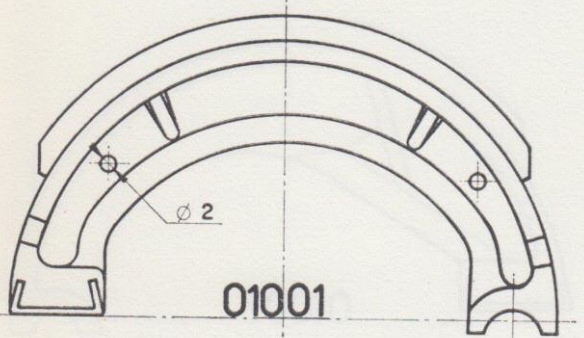

Ø 90 x 20

## WIPPERMANN

Rex, Power, Union

**o1001**

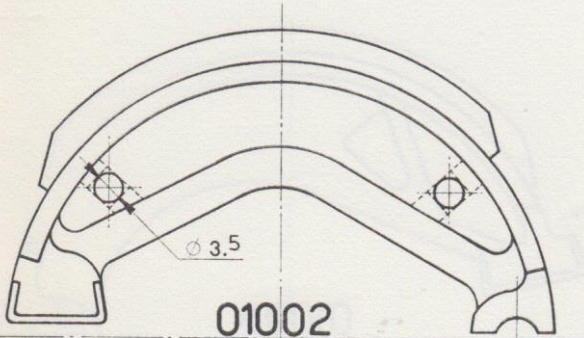

Ø 90 x 20

## PUCH

MS-50; MS-50 L; MS-25

**o1002**

Nr. origin. 350 1 40 115 0

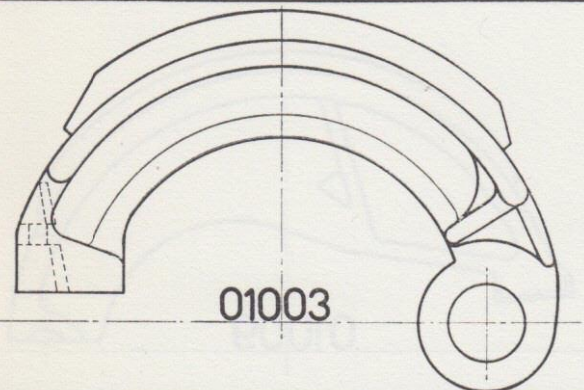

Ø 90 x 21

## MAILLARD

Rex: Monaco S/2, S/3;  
Mobylette: S 25 1960/61;  
RICO: Paloma; Prior; VAP Velo  
RAP 1962 - Cyrus  
Express: Radexi

**o1003**

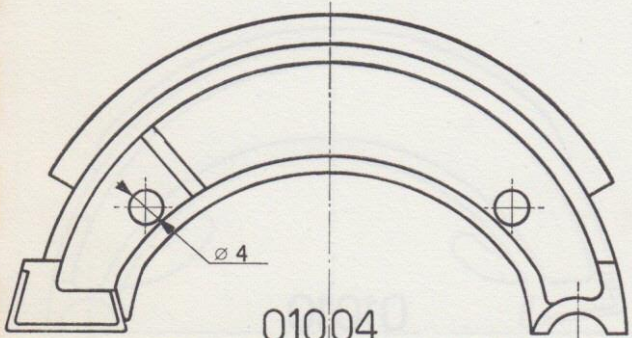

Ø 90 x 20

## SACHS

V 90, V 90 V, H 90, H 90 V,  
H 90-12, H 90 VS  
Hercules: 216, 217, 218

**o1004**

Nr. originale 0871 025 700



**o1005**

**IDEAL**

Mobylette: AV 3 SI, AV 75  
Typhoon; Paloma; Diesella;  
Express: Teknik  
Wittler; VAP 631

Ø 90 x 22

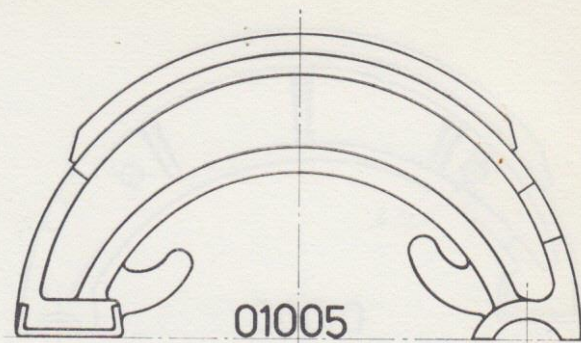

**o1007**

**ZUNDAPP**

405 - 422 - 423

Nr. originale 4018

Ø 90 x 20

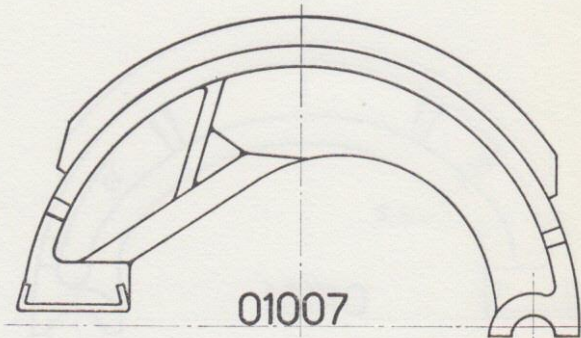

**o1008**

**ZUNDAPP**

425 Falconette  
425 Combinette

Nr. originale 4696

Ø 90 x 25

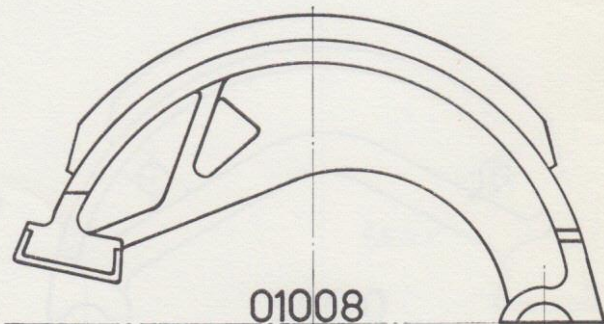

**o1009**

**ZUNDAPP**

429 - 433 Super Combinette  
425 Falconette, 510 KS 50,  
511 KS 75, GTS 50 Cross,  
type 517-39, 514 KS 100

Nr. originale 51396

Ø 120 x 25

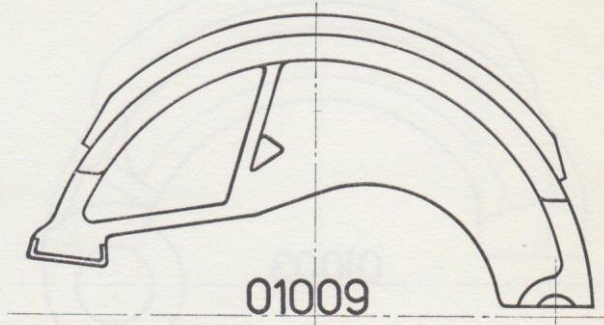

**o1010**

**IDEAL**

Mobylette

Ø 118 x 24

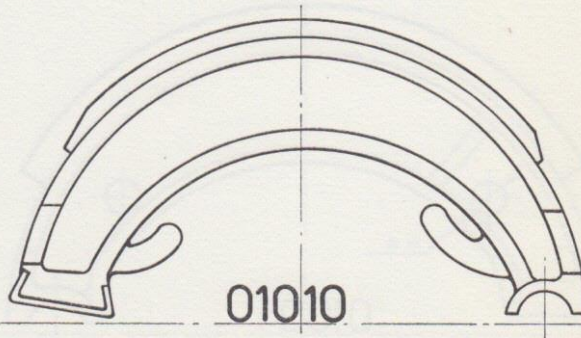

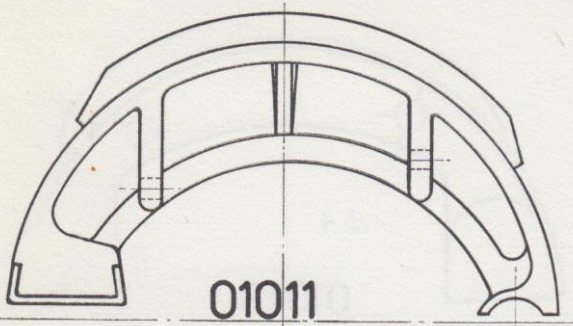

Ø 80 x 16

01011

**PRANAFA**

VFB-HFB 80; Kreidler Junior  
amazzone; Zundapp:  
401, 402, 403, 404, 406

**o1011**

Nr. originale 1111

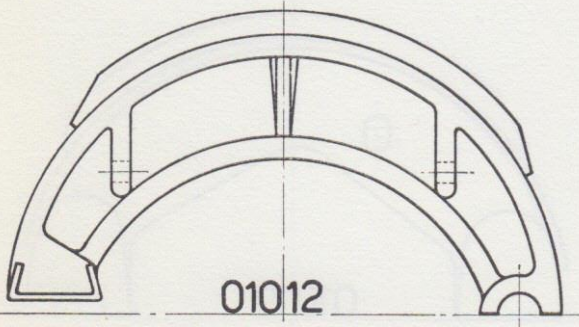

Ø 90 x 18

01012

**PRANAFA**

VFB-HFB 80/90, Sparta;  
Kreidler J50, J51,  
Mobylette S1-S2; Sachs

**o1012**

Nr. originale 2912

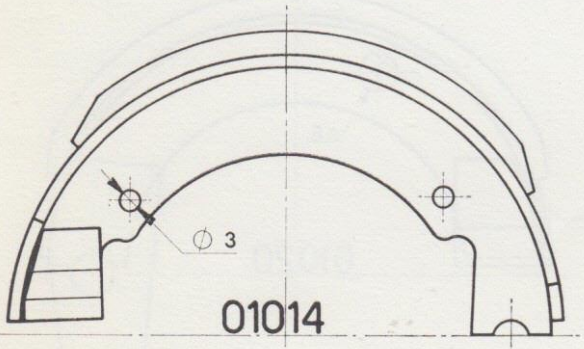

Ø 90 x 18

01014

**PRANAFA**

VFB-HFB 80/90 V; Union 6048;  
Express Radexi III; Zundapp;  
Fongers; Rex: Monaco, Como  
1958; Puch; Sparta

**o1014**

Nr. originale 6048

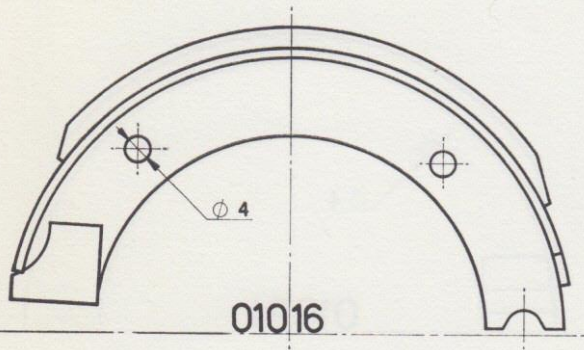

Ø 105 x 15

01016

**DKW**

Berini: M 21 - M 31 - M 35/36;  
DKW: Hummel Standard  
Luxus 101; Victoria Vicky III  
1955 - Nichy 55/57; Husquarna:  
Roulette, Corona, Cornette

**o1016**

Nr. originale 0101 22231 00

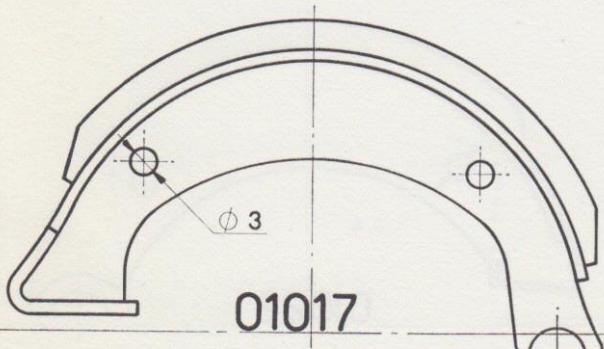

Ø 80 x 20

01017

**WIPPERMANN**

Union MV5-MH5

**o1017**

Nr. originale 0101 22231 00



**o1018**

Nr. originale 16 51 00 509

**NSU**  
Quickly NS5

Ø 90 x 17

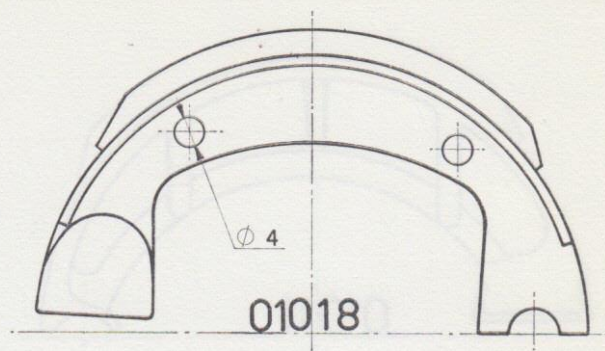

01018

**o1019**

Nr. originale 16 51 02 509

**NSU**  
Quickly SL - Cavallino 1958

Ø 90 x 17

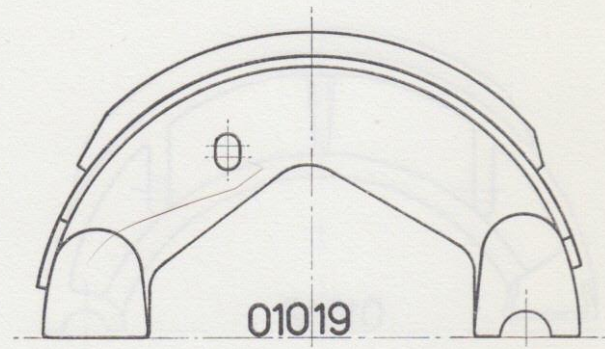

01019

**o1020**

**AVAROS**  
Super 8 1958/61

Ø 90 x 20

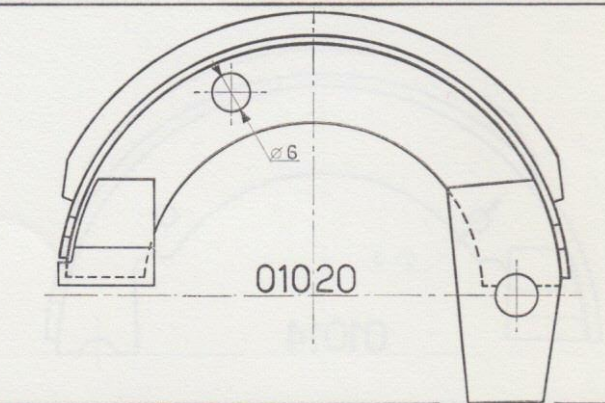

01020

**o1021**

Nr. originale 6451

**PRANAF**  
Pranafa V-VA-H-HA-VL/ DKW;  
Hummel Super;  
NSU Quickly T - Hercules 220;  
Victoria: Superlux;  
Kreidler florette 1959

Ø 120 x 20

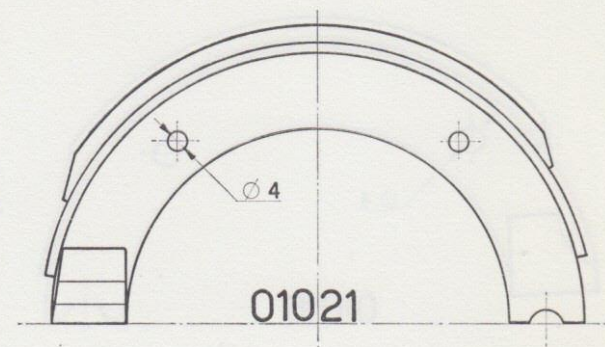

01021

**o1022**

Nr. originale 364 1 40 315 0

**PUCH**  
VS-50S; VS 50 L; DS 50 K;  
VS 50 D; VS 50 DK;  
Roller DS 50 K; VS 50 SK;  
VS 50 DZ; VS 50 DZS; DZ 50 SK2

Ø 105 x 25

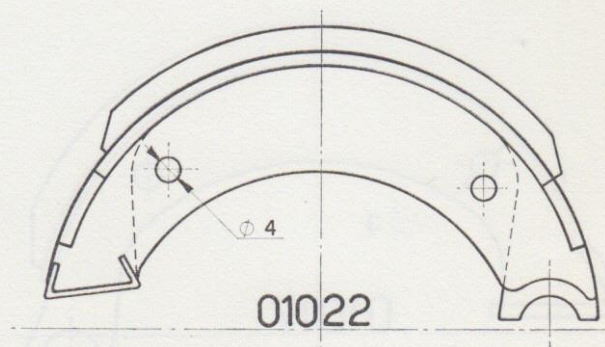

01022

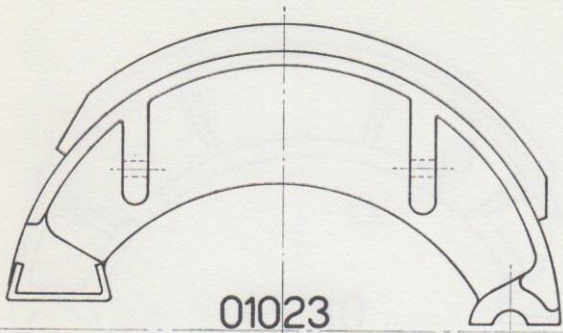

Ø 90 x 18

**MONARCK**

24, 245, 34, 345, 248  
249, 348, 349, 448

**o1023**

01023

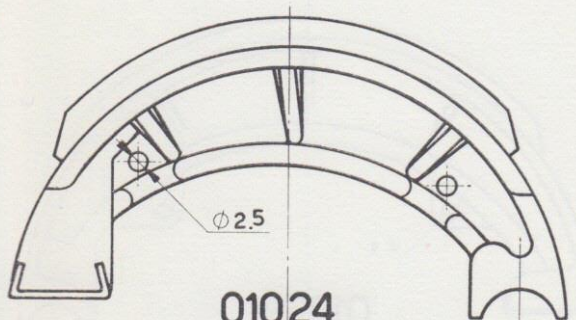

Ø 90 x 23

**AVAROS**

Avaros: Super 7  
Claeys: Superia

**o1024**

01024

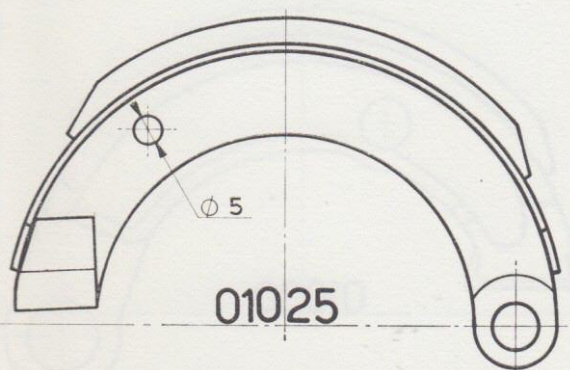

Ø 120 x 19

**AVAROS**

Avaros: Kingline  
Claeys: Flandria

**o1025**

01025

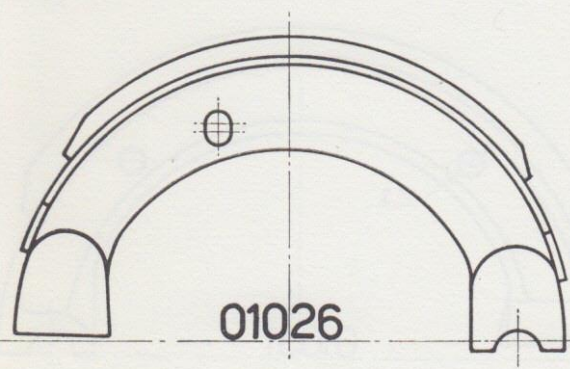

Ø 120 x 20

**NSU**

Quickly T-TT  
Quick 50 PS 4, 3

**o1026**

01026

Nr. originale 29 51 00 501

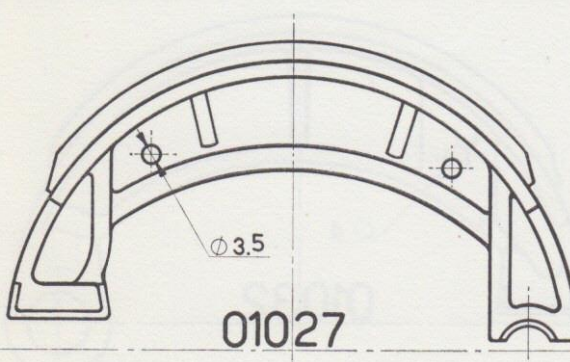

Ø 120 x 20

**ZUNDAPP**

ZU: 115 - 155  
Victoria: 115, 155, 156, 136/166  
DKW: 159 Standard e 159TS,  
Mokick 139 Standard

**o1027**

01027

Nr. originale 900 020 63 00



5 e

# o1028

Nr. originale 103 353 705

## HEINKEL

Tourist 175 cc - 200 cc  
tipo 103A-0 e 103A-2

Ø 140 x 25

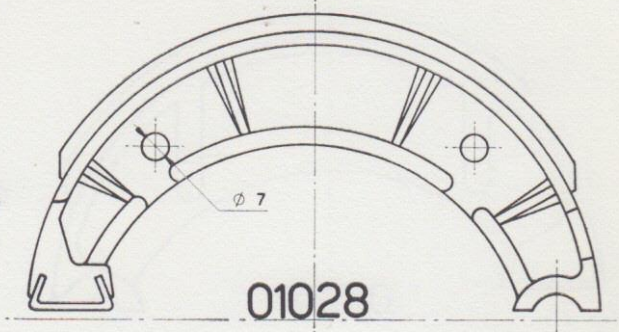

# o1029

Nr. originale 20 z 108

## ZUNDAPP

Roller; Bella, R 150 - R 151  
R 153 - R 154 - Bella 175 S  
R 200 - R 201 - R 203 - R 204

Ø 150 x 25

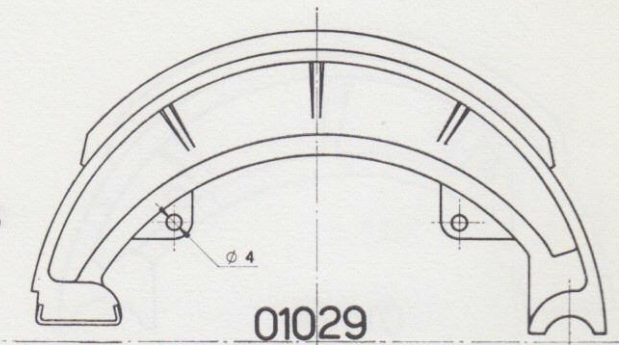

# o1030

Nr. originale 0871 033 000

## SACHS

V 90 - V 901 - HS 90 VE  
H 90 VE - HR 90 V  
Mola 25; Hercules: L50, 219,  
221 Automatik

Ø 90 x 18

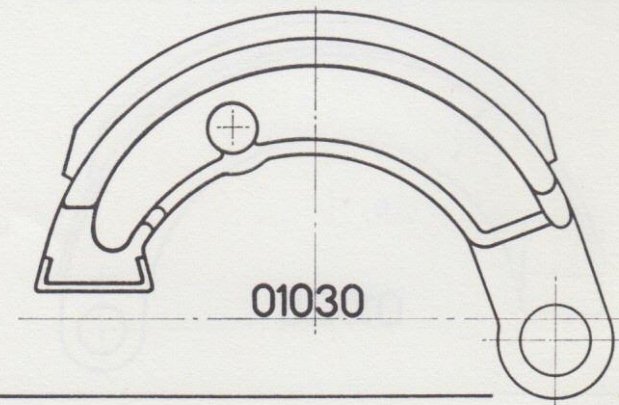

# o1031

## MAILLARD

Panther K9

Ø 118 x 23

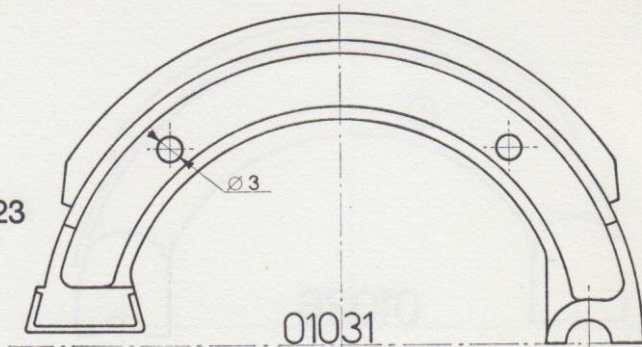

# o1032

Nr. originale 0873 100 004

## SACHS

Hercules 220 K - SK - MK  
MKL - MKF - K 50 - K 102  
Sachs: V 115/VI, HS 115,  
V 50, HS 115 V

Ø 115 x 23

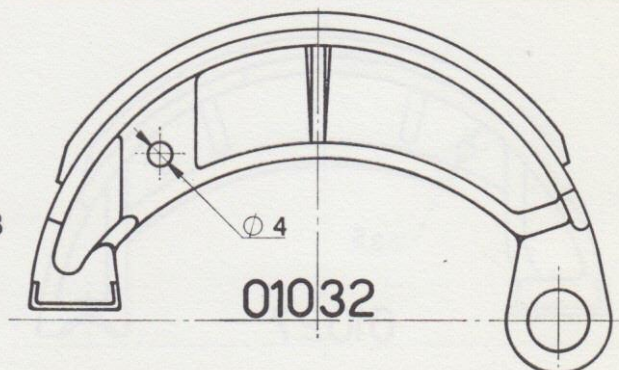



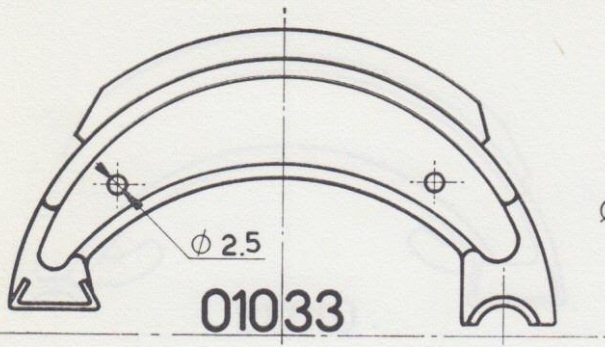

Ø 105 x 20

MAILLARD  
DKW: Hobby

o1033

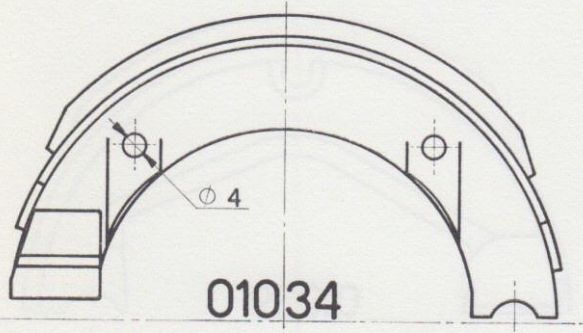

Ø 115 x 20

UNION  
Sparta: 1962

o1034

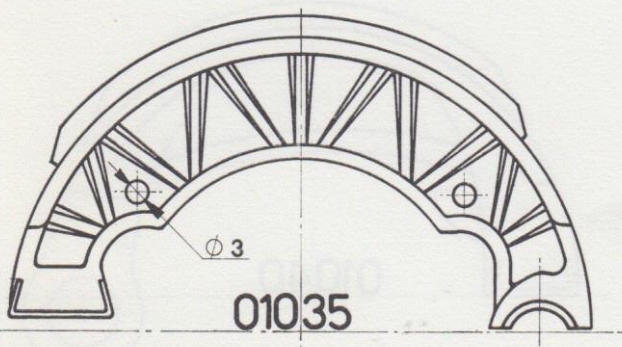

Ø 105 x 20

GRAJAN  
HMW  
Moped Super Sport 50 cc.

o1035

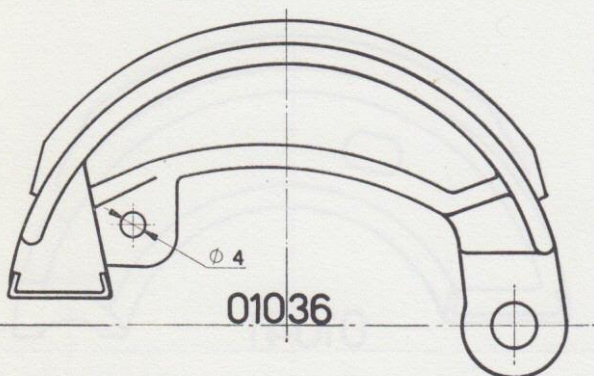

Ø 120 x 23

CLAYES  
Superia

o1036

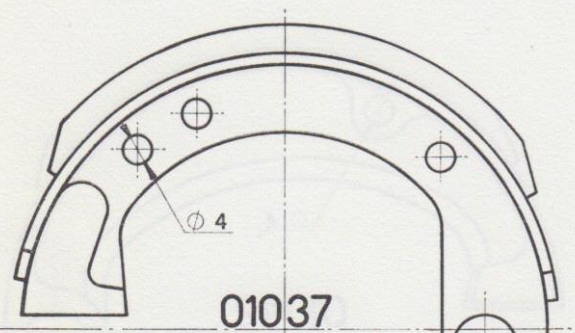

Ø 90 x 20

CRESCENT  
Crescent 1134 - 1134 K - 1138

o1037



**o1038**

**IDEAL**  
Mobylette AV65

Ø 100 x 23

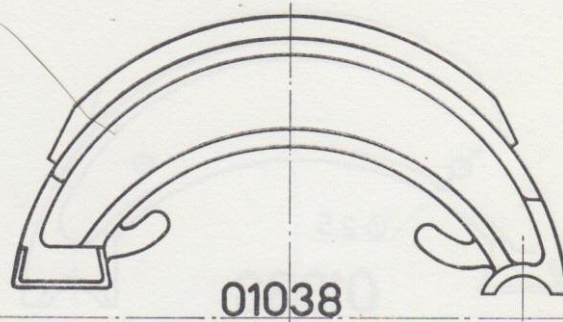

**o1039**

**GIGANT**  
Phillips: Gadabout

Ø 102 x 20

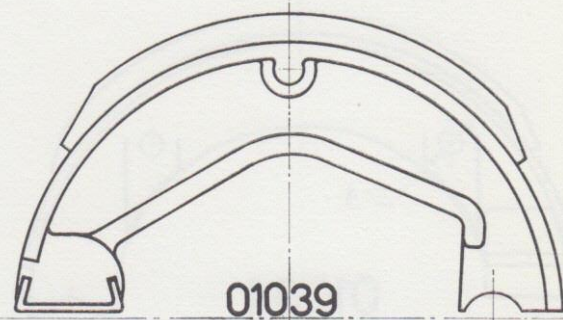

**o1040**

**PRIOR/MAILLARD** Ø 85 x 20  
Prior - Flandria - Berini: 2G

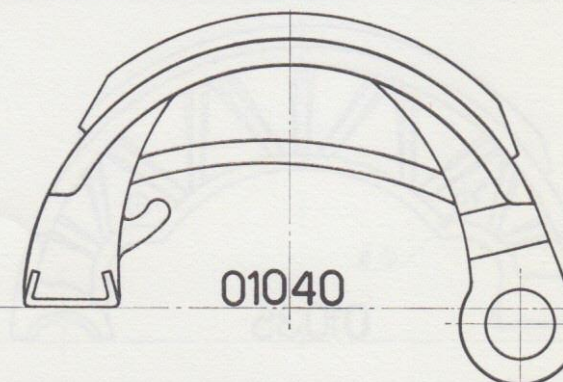

**o1041**

**JAWA**  
Jawa 50 cc.

Ø 82 x 16

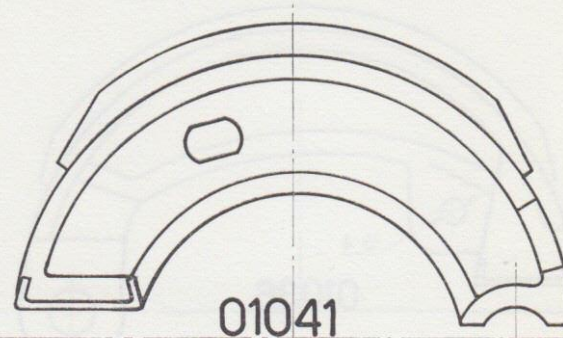

**o1042**

**CRESCENT**  
Crescent 1140 - 1142, 2001

Ø 90 x 20

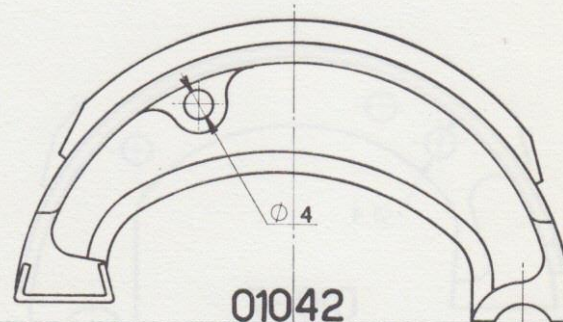

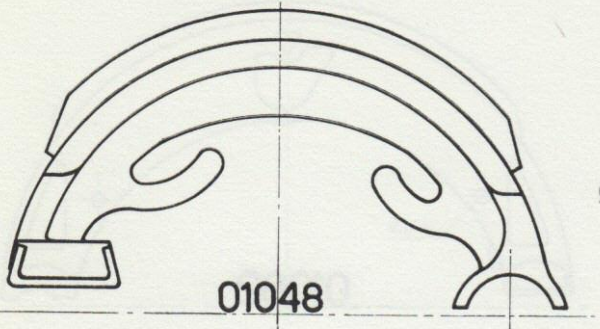

Ø 70 x 20

**LELEU**

Mobylette Cady - Velosolex

**o1048**

Nr. originale 18 027

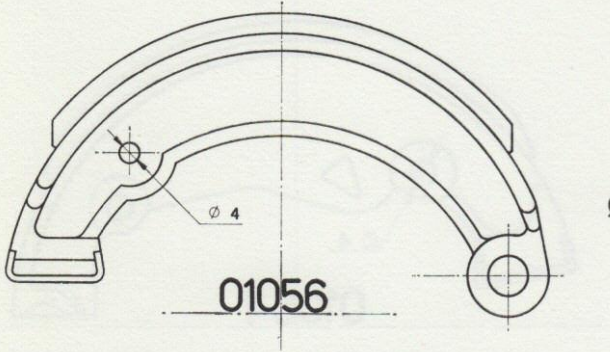

Ø 120 x 25

**SIMSON**

Simson 3V

**o1056**

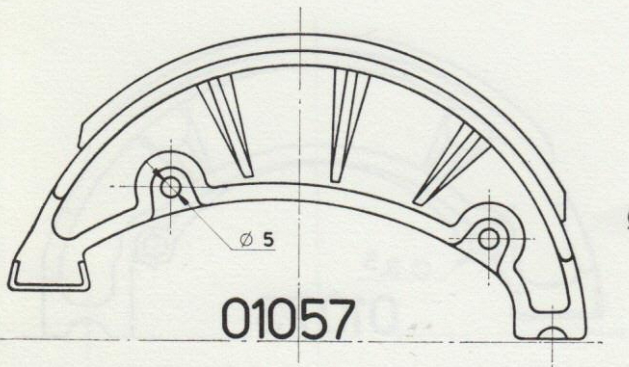

Ø 150 x 25

**ZUNDAPP**

Zundapp KS 50 Sport  
Super Sport KS50 - KS50 Cross  
tipo 517 - 51 LO 73-74

**o1057**

Nr. originale 517 15 609

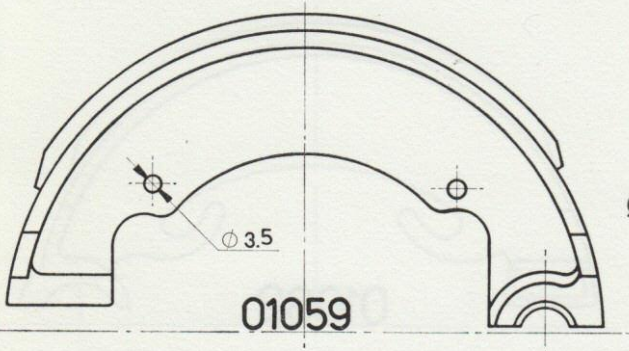

Ø 138 x 25

**BSA**

BSA: Bantam D7 - 175 cc.  
Triumph Cub

**o1059**

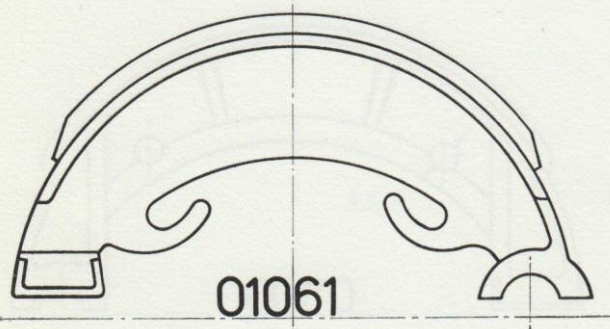

Ø 100 x 20

**LELEU**

Mobylette

**o1061**



9 e

**o1062**

Nr. originale 06 12 32

**KREIDLER**

Florette RS 1967

Ø 150 x 20

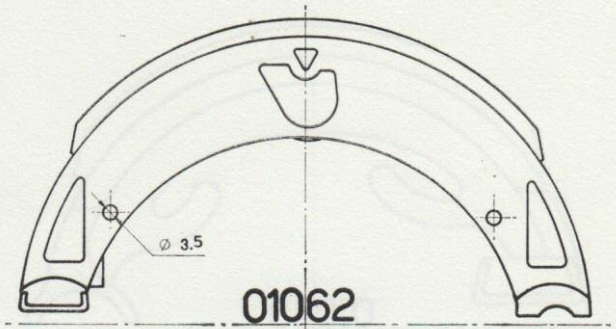

**o1064**

**ZUNDAPP**

Zundapp 100 cc 1969

Ø 120 x 25

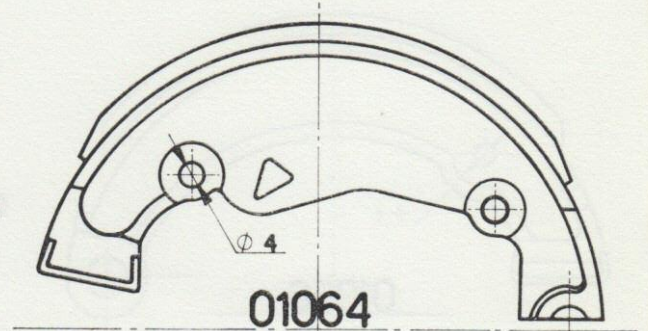

**o1073**

**SUZUKI**

Suzuki

Ø 110 x 30

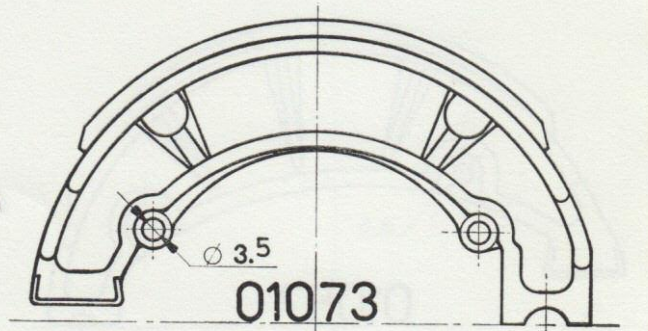

**o1082**

**LELEU**

Mobylette

Ø 100 x 20

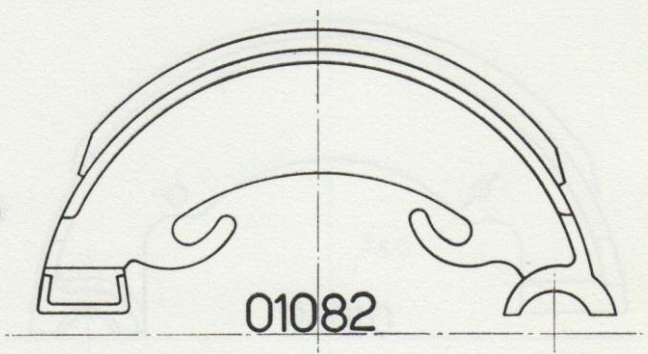

**o1100**

Nr. originale 0873 104 000

**SACHS**

Sachs 1968; Union 159 TS  
e 159 TS Super; RT 159  
RT 159 Super - Hercules:  
K 50 SX, K 50 RX, K 50 SE,  
K 50 RE; K 50 GS

Ø 140 x 25

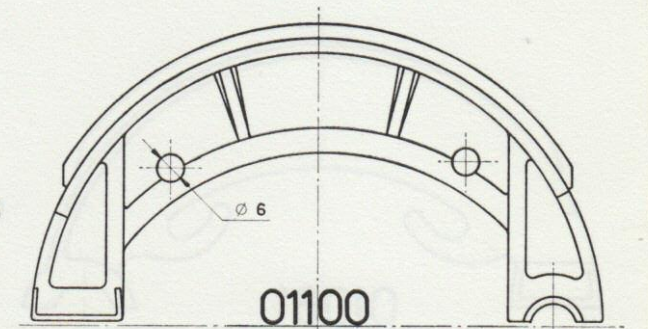

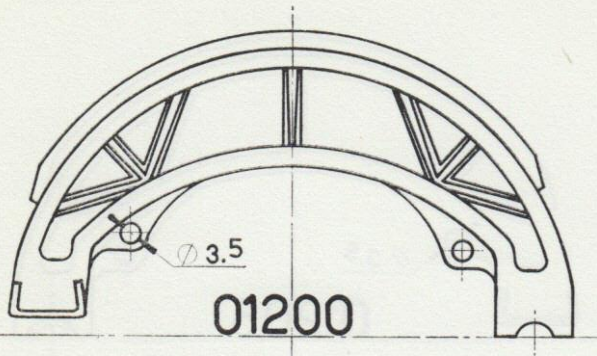

Ø 110 x 25

**HONDA**

Honda c. 110 - c. 111 - c. 114  
c. 115 - SS50, S90,  
Sport Cub 50

**o1200**

Nr. originale 45 120 001 010

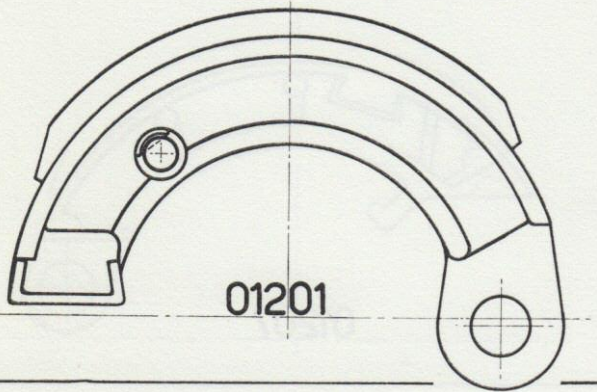

Ø 90 x 17

**OGLAND**

Gigant

**o1201**

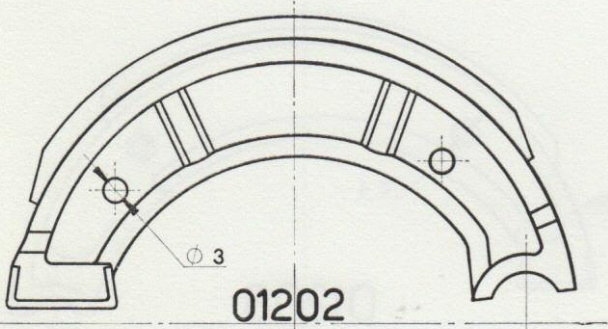

Ø 90 x 20

**SIMSON**

Simson

**o1202**

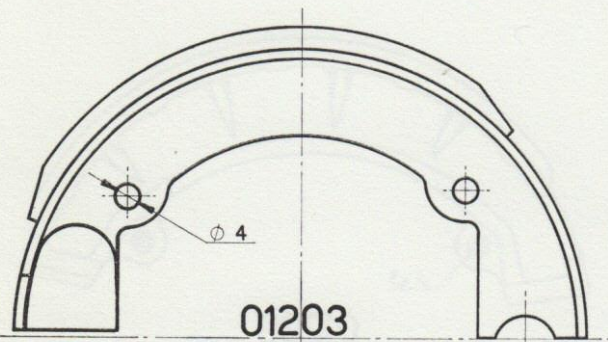

Ø 118 x 20

**CRESCENT**

Crescent Transport Moped

**o1203**

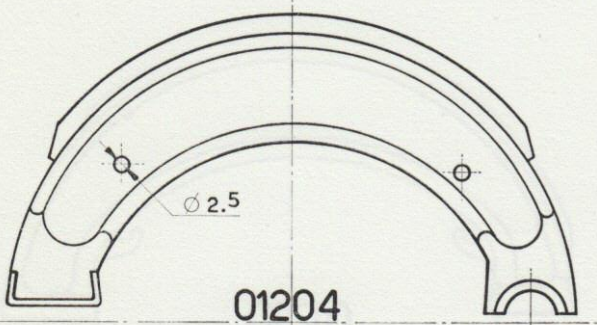

Ø 140 x 20

**HUSQUARNA**

Husquarna: Silverpilen

**o1204**



**o1205**

**YAMAHA**

Yamaha 50 cc.

Nr. originale 122 25330 00

Ø 110 x 25

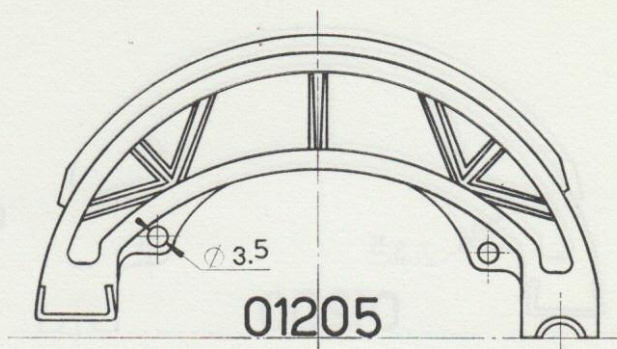

**o1207**

**GRIMECA**

Grimeca Mebea

Ø 140 x 32

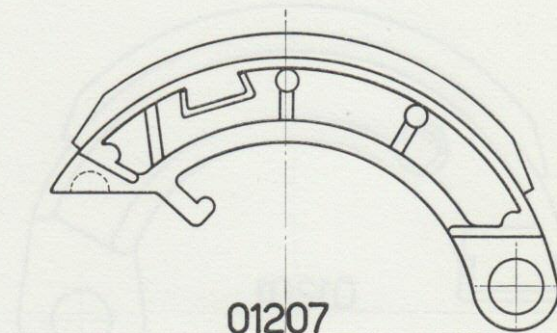

**o1208**

**SHL**

SHL

Ø 160 x 40

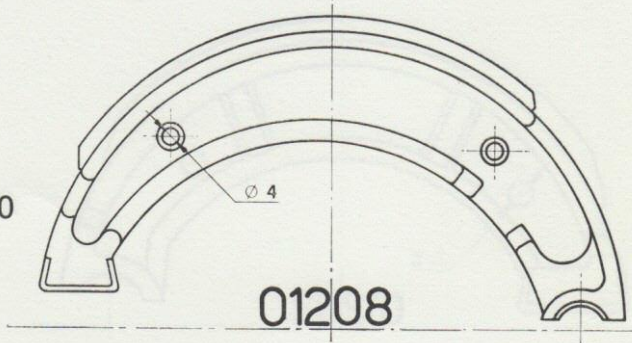

**o1209**

**BSA**

BSA - Triumph

Ø 200 x 40

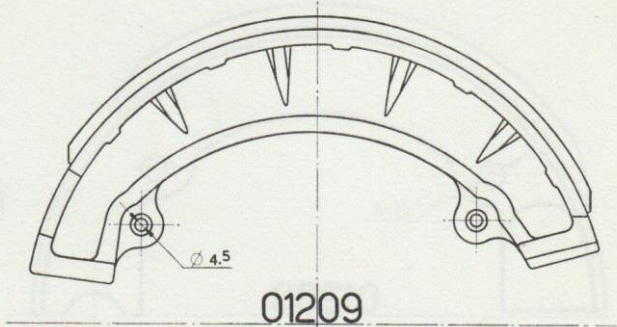

**o1210**

**BSA**

BSA - Triumph

Ø 180 x 28

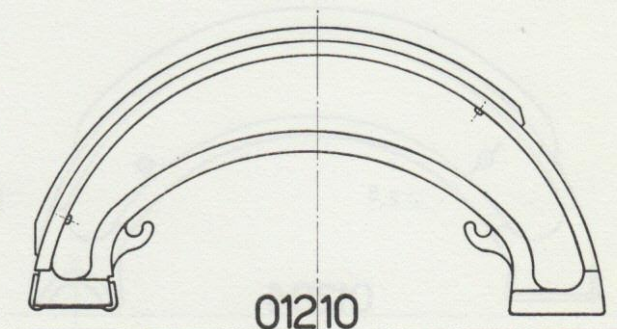

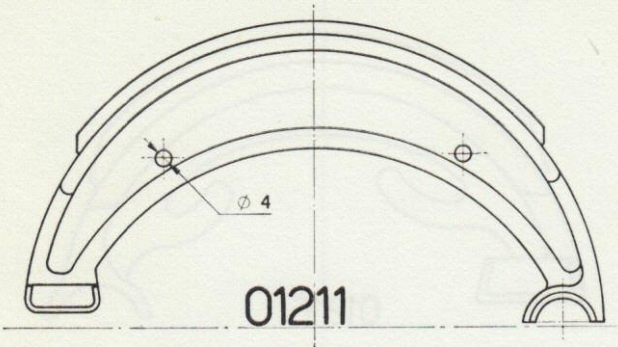

∅ 160 x 25

**HUSQUARNA**  
Husquarna

**01211**

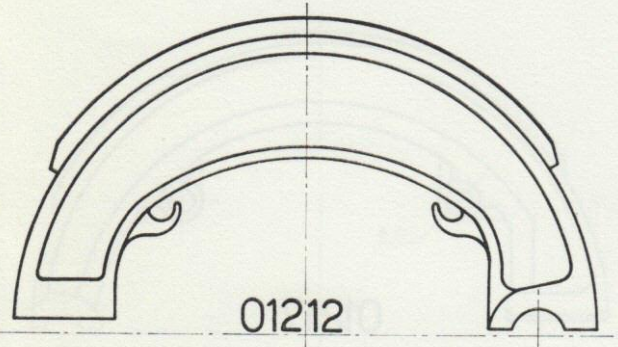

∅ 152 x 22

**BSA**  
BSA Triumph

**01212**

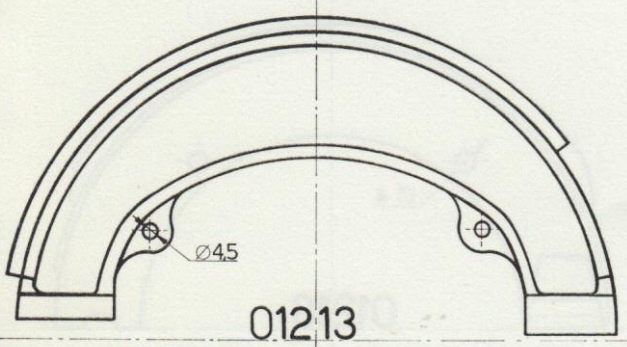

∅ 177 x 28

**BSA**  
BSA Triumph

**01213**

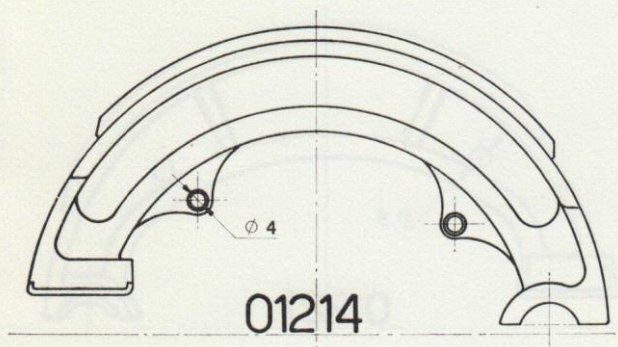

∅ 160 x 25

**BRITISH - HUB - KART**  
British - Hub - Kart

**01214**

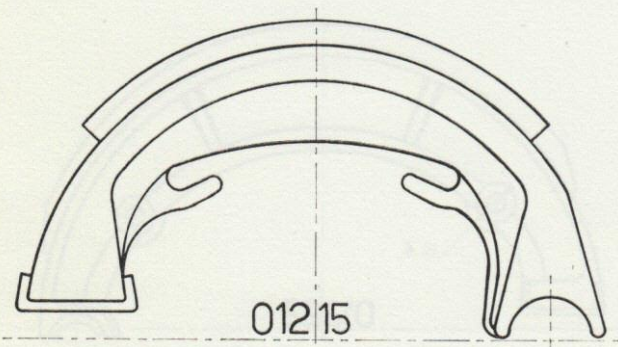

∅ 70 x 15 **PEUGEOT S.G.D.G.**  
Peugeot 102 - Honda: Amigo  
Mobylette Cady MI PRT - PRTS

**01215**



**o1216**

**PEUGEOT**  
Prior

Ø 70 x 20

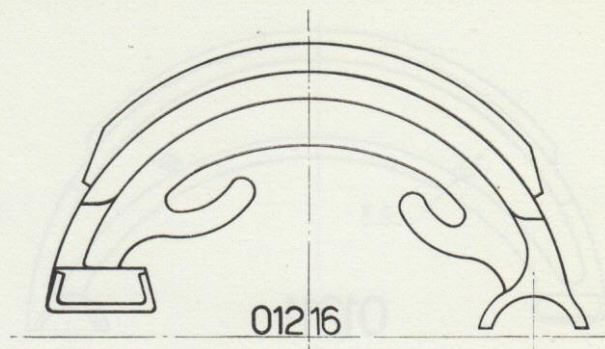

**o1217**

**CZ**  
Halman

Ø 180 x 25

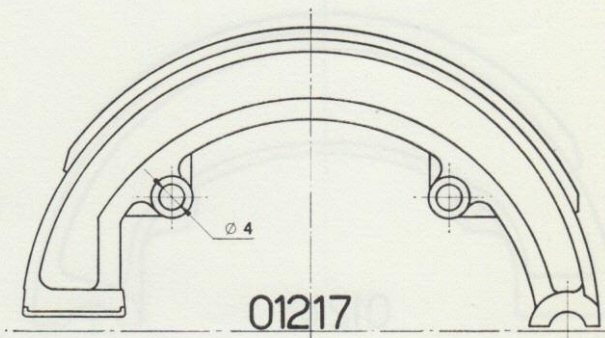

**o1218**

**BALKAN**

Ø 130 x 24

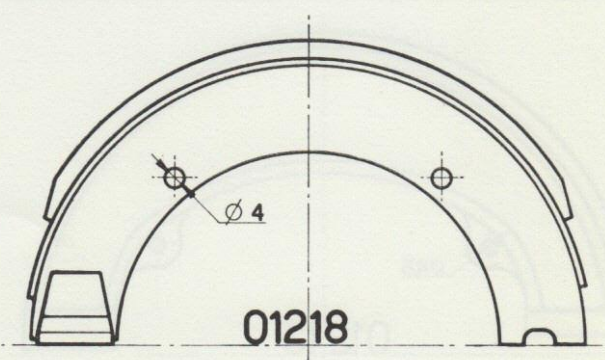

**o1221**

**MAICO**

Ø 130 x 30

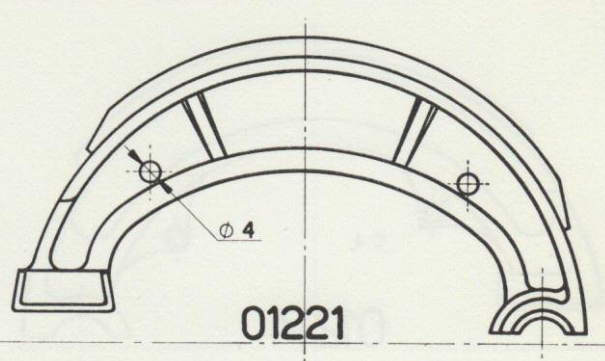

**o1222**

**MAICO**  
M 250 Blizzard  
Roller Maicoletta 175 e 250 cc.

Ø 160 x 30

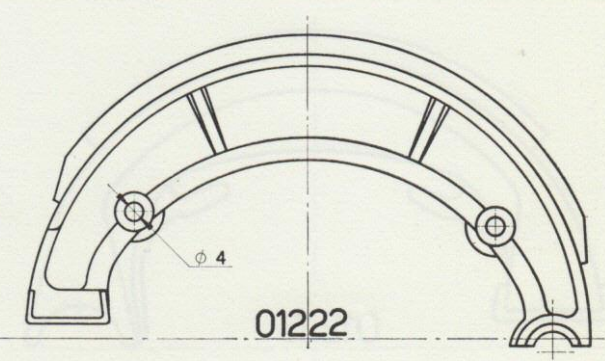



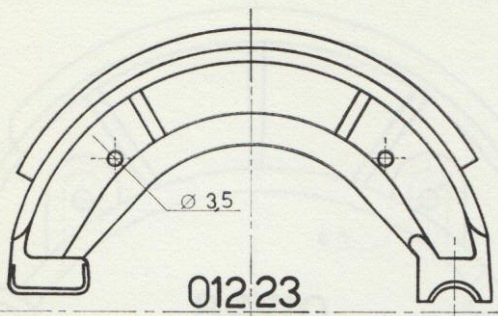

Ø 120 x 22

**OSSA**  
Ossa 250 tr.

**01223**

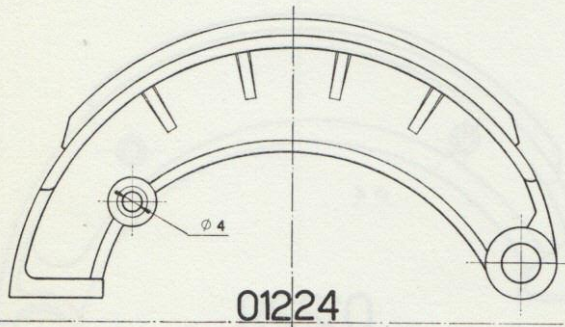

Ø 164 x 35

**CZ**  
CZ 125-175

**01224**

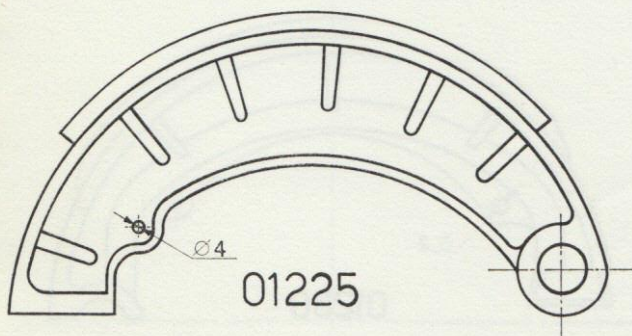

Ø 160 x 35

**JAWA**  
Jawa 250 cc.

**01225**

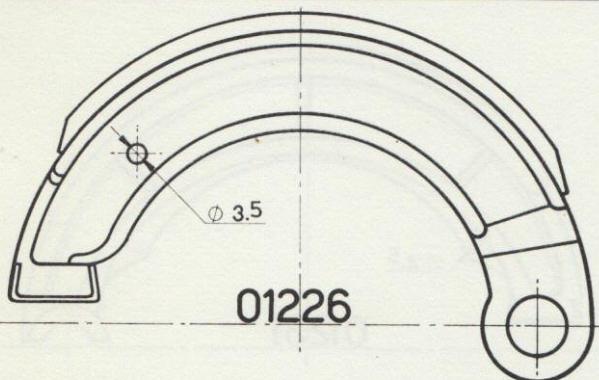

Ø 130 x 30

**KTM**  
KTM 125 cc. regolarità

**01226**

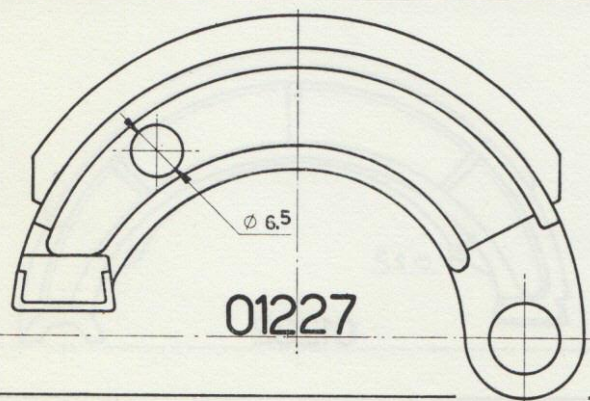

Ø 85 x 17

**HONDA**  
Honda 50 cc. Moped 85

**01227**



**o1228**

MONTESA

Ø 150

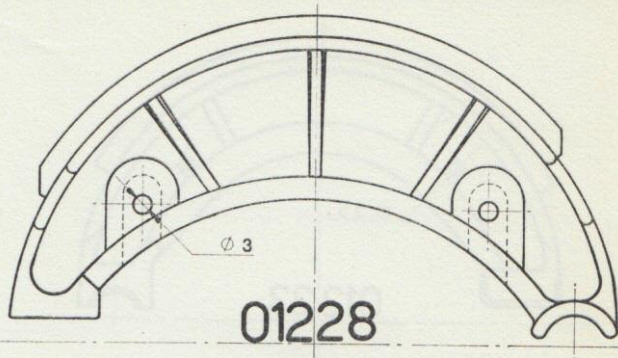

**o1229**

PUCH

Ø 160 x 35

Puch 125 cc. - 175 cc.

Nr. originale 411 1 40 015 0

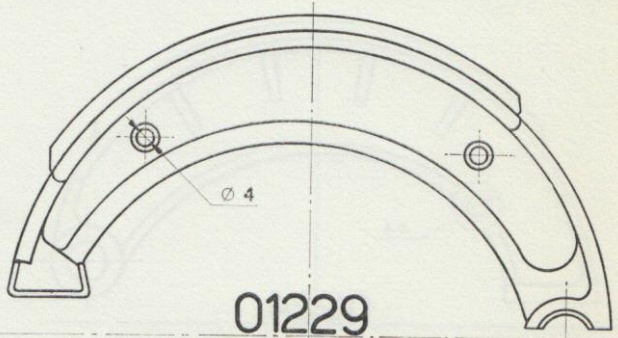

**o1230**

SUZUKI

Ø 150 x 28

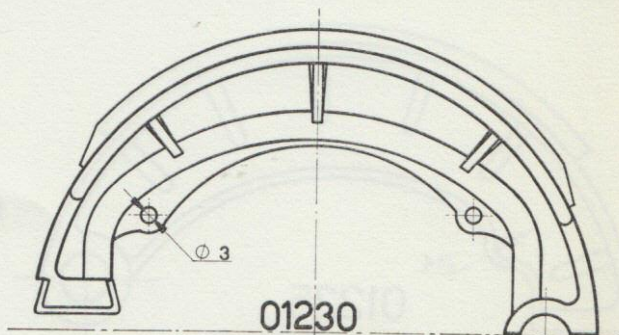

**o1231**

SUZUKI

Ø 180 x 28

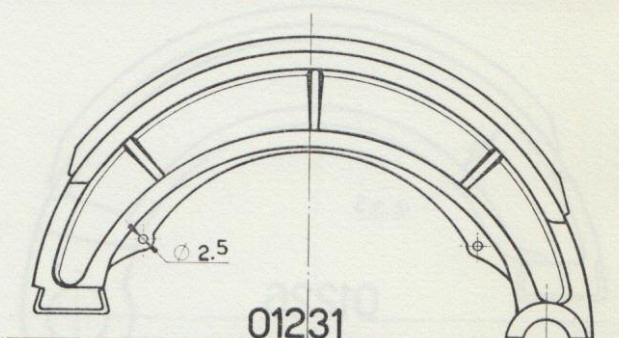

**o1232**

SUZUKI

Ø 180 x 40

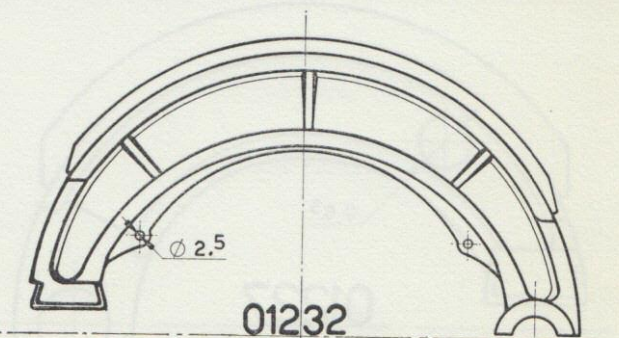

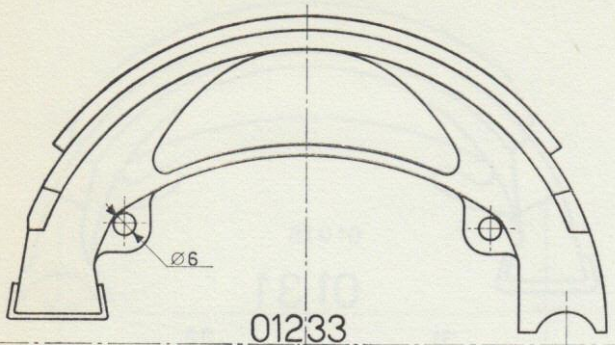

Ø 160 x 25

**KREIDLER**

Kreidler RS modello 1973  
Monark 125 cc.

**o1233**

Nr. originale 06 15 82

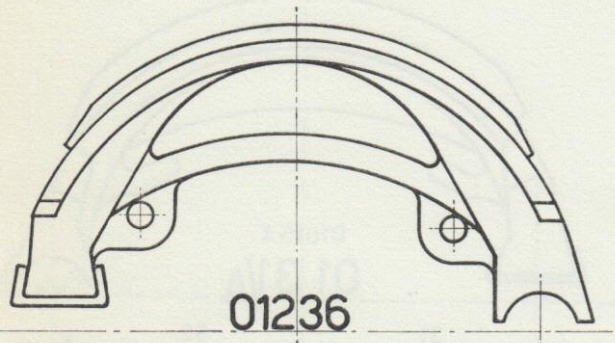

Ø 120 x 20

**KREIDLER**

Kreidler RM-LF  
Husquarna 125  
Monark 50; Leleu

**o1236**

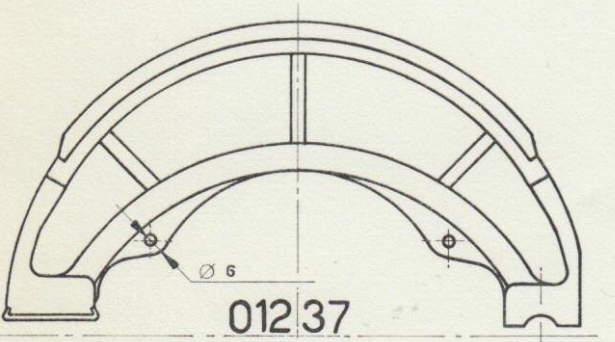

**SUZUKI**

**o1237**

Nr. originale 54410 07001

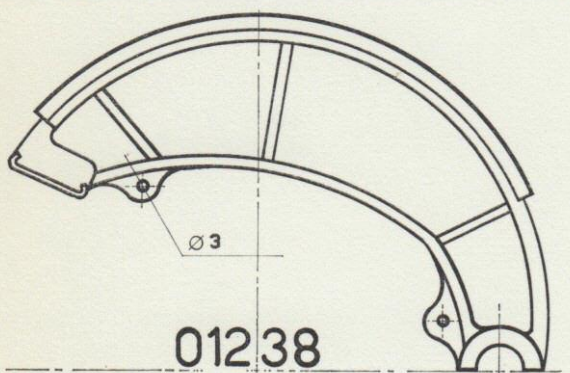

**SUZUKI**

**o1238**

Nr. originale 54410 15000

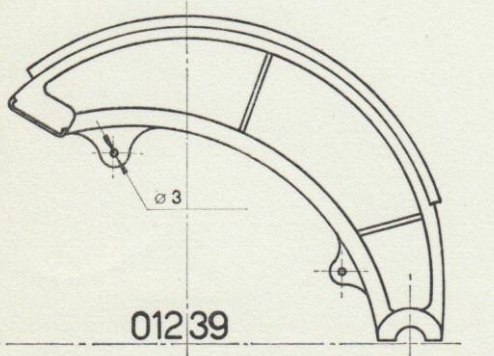

**SUZUKI**

**o1239**

Nr. originale 54410 11002



**o131**

Nr. originale 17 285

**PRIOR**

VAP 610  
Mobylette: AV 44 - AV 76

Ø 80 x 20

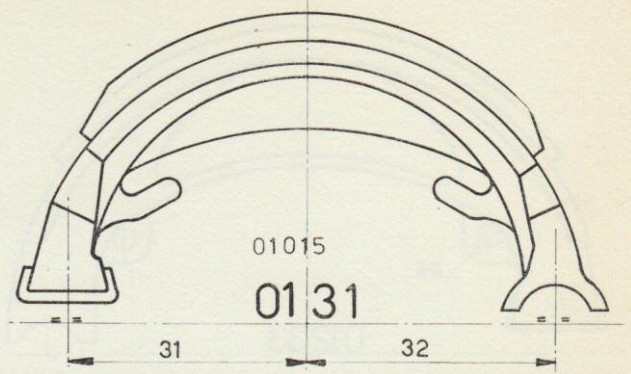

**o131/A**

Nr. originale 061 514

**LELEU**

Peugeot - Sparta - Batavous

Ø 80 x 20

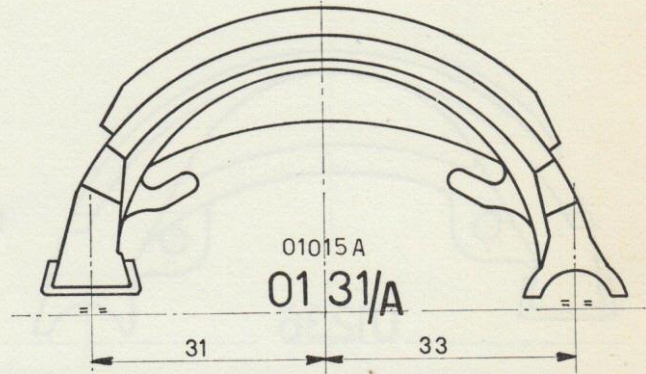





# IceniCAM Information Service

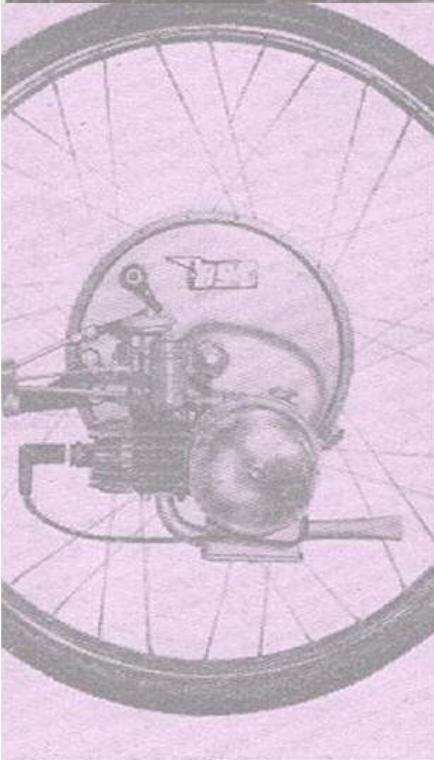

[www.icenicam.org.uk](http://www.icenicam.org.uk)